

**THE**

# *Hemingray Glass Co.*

**A MOST COLORFUL HISTORY**

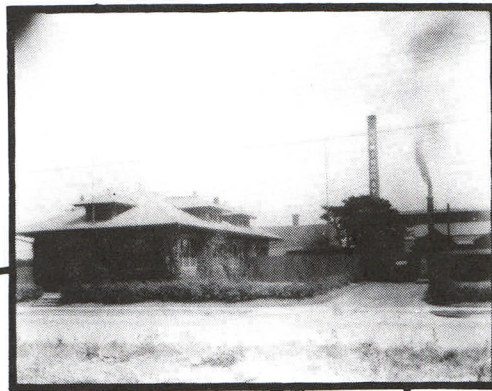

*Places*



*People*

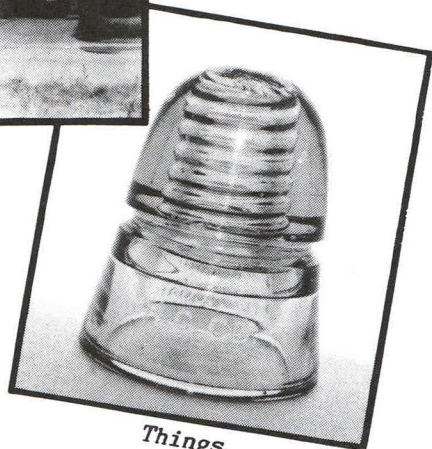

*Things*

**BY**  
**H.G. "BEA" HYVE**

Copyright © 1998 by Clarice Gordon

Library of Congress Catalog Card Number: 97-75232

ISBN 0-9661323-0-0

All rights reserved. No part of this book may be reproduced in any form without permission in writing from the author.

Clarice Gordon, publisher, author

Printed by Your Neighborhood Printer  
San Diego, California

First edition

Printed in the United States of America

Additional copies of this book may be ordered from:

Clarice Gordon  
3269 N. Mountain View Drive  
San Diego, CA 92116-1736



# TABLE OF CONTENTS

Table of Contents.....	iii
Dedication.....	vii
Beginning Notes.....	ix
Cover Credits.....	xi
Other Credits.....	xii
Forward.....	xiii
A Few Notes about the Contents of the Book.....	xiv
Hemingray People, Part I.....	1
Cincinnati, Ohio.....	5
Covington, Kentucky.....	6
Muncie, Indiana.....	6
The People.....	6
Samuel J. Hemingray.....	6
Robert Hemingray.....	7
Ralph Gray Hemingray.....	11
Robert Carroll Hemingray, Jr.....	14
Daniel Carroll Hemingray.....	15
Reuben Hemingray.....	18
Joseph Conway Hemingray.....	19
Richard G. Evans.....	19
Edward D. Swasey.....	20
James L. Foley.....	20
Bradford Shinkle.....	21
Amos Clifford Shinkle, Jr.....	23
Philip Warrington McAbee.....	25
Ralph Gray.....	27
Anthony Gray.....	27
James C. Gill.....	28
Willard Paul Zimmerman.....	28
Positions Held by Various People at Hemingray at Various Times, 1848-1933.....	30
Where the People are Buried.....	37
Obituaries.....	52
The Hemingray Silver.....	81
Hemingray Places, Part II.....	83
Setting the Scene.....	85
Pennsylvania.....	87
Cincinnati, Ohio--Then.....	87
Cincinnati, Ohio--Now.....	94
Covington, Kentucky--Then.....	98
Covington, Kentucky--Now.....	109
Muncie, Indiana--Then.....	121
Muncie, Indiana--Now.....	133
The Hemingray Dump.....	147
Hemingray Homes.....	148
Residences of Hemingray People in Covington, Kentucky, 1860-1920.....	155
Residences of the Hemingrays in Muncie, Indiana, 1889-1924.....	159

Hemingray Things, Part III.....	161
Why Glass?.....	166
Company Embossings.....	166
"Dec. 19, 1871".....	166
"H. G. CO.".....	169
"HEMINGRAY".....	169
"PETTICOAT".....	171
"LOWEX".....	173
Drip Points.....	174
Preliminary to Glassmaking.....	174
Cullet.....	176
Molds and Presses.....	179
The Furnaces.....	182
Coal.....	183
Gas.....	183
A Few Production Notes on the Three Hemingray Factories.....	184
Working Conditions.....	189
The Glassmaking Process at Hemingray.....	190
Ingredients.....	191
Colorizing.....	193
To the Furnaces.....	194
Into the Mold.....	195
Out of the Mold.....	197
To the Annealing Lehr.....	197
Inspection.....	198
To Work.....	201
Some Lovely Hemingray Insulators.....	202
And Finally.....	204
The Family Tree Room.....	207
A Few Notes about The Family Tree Room.....	209
Genealogy Chart Numbers for Those on Charts and in Text.....	210
The Hemingray Family Tree.....	211
Genealogy Charts.....	212
Genealogy Chart for the Grays.....	238
The Mail Room.....	239
A Few Notes about The Mail Room.....	241
Letter to Author from Ern Parkison.....	242
Letter from Owens-Illinois about Closing of Plant.....	244
Letter from Owens-Illinois to Glenn Drummond.....	245
Letter to Hemingray from Lawyer Arthur Stem.....	246
The News Room.....	249
A Few Notes about The News Room.....	251
The Ad Room.....	299
A Few Notes about The Ad Room.....	301
Ads.....	302
Catalog Pages.....	337
The "Catch-All" Room.....	381
A Few Notes about The "Catch-All" Room.....	383
The Mystery Bride.....	384
Excerpts from the <u>History of Delaware County, Indiana,</u> <u>Vol. II,</u> by Frank D. Haimbaugh.....	391
Short History of Muncie Owens-Illinois.....	392



The "Catch-All" Room continued	
Laws of Kentucky—Incorporation Papers.....	393
Drip Points.....	395
Incomplete List of Registered Trademarks and Patents Granted to Hemingray and Owens-Illinois and/or Their Assignors.....	397
May 2, 1893, Patent.....	398
Dec. 19, 1871, Patent.....	400
Nov. 13, 1883, Patent.....	403
Feb. 12, 1884, Patent.....	405
"HEMINGRAY" Trademark Registration.....	407
"LOWEX" Trademark Registration.....	409
Furnace Notes.....	410
Aug. 8, 1916, Patent.....	426
<u>Official Gazette</u> Relating to Insulator Patent Controversy.....	439
Owens-Illinois Job History.....	441
1948 Speech Given at Awards Ceremony.....	442
The Book Room.....	447
A Few Notes about The Book Room.....	449
Insulator and Go-With Publications.....	450
Final Notes.....	453
Acknowledgements and Thanks.....	455
The National Insulator Association.....	463
About the Author.....	464
Soozie.....	466
List of Abbreviations Used in Index.....	468
List of Publication Name Abbreviations Used in Index.....	468
Index.....	471
The End.....	481





This book is dedicated to

## **MR. N.R. WOODWARD**

of Houston, Texas,  
who started collecting insulators  
in the 1930s,  
began researching them  
in the 1950s,  
and wrote the first book on insulators  
in 1965.



CD 115







# BEGINNING NOTES

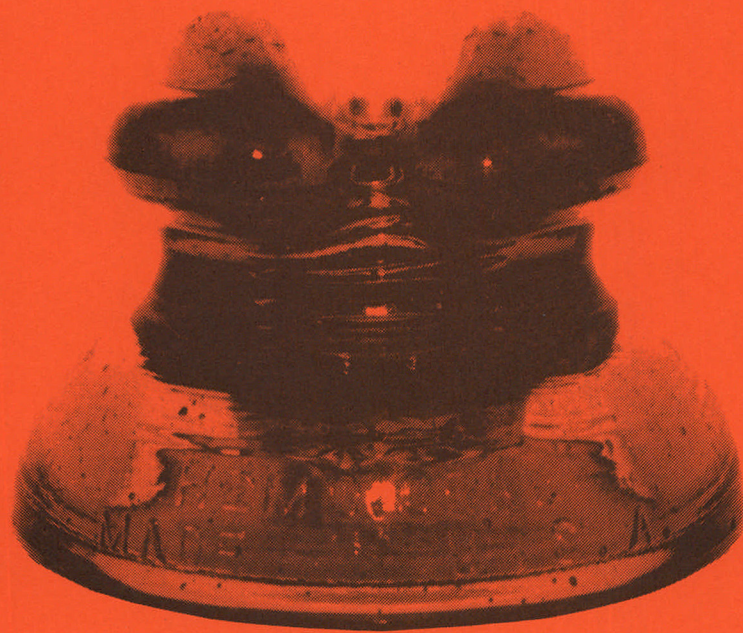

CD 230





## COVER CREDITS

I thank Timothy Sternke of Milwaukee, Wisconsin, for allowing me to use the restored version of the words "Hemingray Glass Co." so expertly done by his father, Earl J. Sternke. This lovely style of lettering originally appeared on a company invoice dated 1896.

My thanks go to The Olde San Diego Gazette of San Diego, California, for the graphics I've used on the title page and throughout the book. Karen Spring, editor-in-chief, was kind enough to make them for me on their computer. The font style is called "saddlebag plain." (An example can be seen above.)

I am grateful to the Cincinnati Historical Society for the photo of Daniel Hemingray which is in their collection. (See page 16 for credit details.) Many thanks to Linda Bailey, curator of prints and photographs, for permission to use the photo here and elsewhere in my book.

The photo of the Hemingray Glass Company at Muncie was a gift from Jim Sanders of Ojai, California, and I thank him so much. The original photo was taken around 1924. I also want to thank Mike Sovereign of Lombard, Illinois, who photographed his copy of this same photo for me over 20 years ago.

Soozie, the H. G. CO. PETTICOAT beehive insulator, CD 145, is from my collection, and is the one "that started it all". She always wanted to be a cover girl, and now she has her wish. This photo of Soozie and the ones appearing on pages 466 and 481 were taken by John McDougald of St. Charles, Illinois, for which I thank him. (Read more about Soozie on page 466.)

Drip points have long been a feature associated with Hemingray insulators, and for this reason I chose them as the main design theme for my book. They are known as "SDP" to insulator collectors, or "sharp drip points". (There are also round drip points, or "RDP".) The drip points used on the cover and elsewhere were designed for the National Insulator Association's quarterly newsletter Drip Points by editor Tom Katonak of Corrales, New Mexico. Tom also made the border for me on his computer. The drip points used on the cover and on other pages in my book are used with Tom's permission. I thank him for the border design and for granting permission for use of the drip points.



## OTHER CREDITS

The lovely insulator photos pictured on the title pages of each section of my book, the photo of the CD 115 on the dedication page, as well as the insulator photos shown under "Some Lovely Hemingray Insulators" (pages 202 and 203), were generously provided by John and Carol McDougald of Saint Charles, Illinois. Carol also provided the information for "The Book Room" on insulator and related publications, which was taken from her magazine Crown Jewels of the Wire. I am deeply grateful to this hard-working couple for these contributions, as well as for the countless other things they have done to help me with this book.

The Hemingray logo used on the last page of every section was taken from a Hemingray catalog, Bulletin No. 1, 15 May 1921, a copy of which was given to me by Mike Sovereign of Lombard, Illinois. (See a copy of the logo on page xiv.)

The signatures seen in Part I are actually those of the people themselves, and are from various sources. Those of Philip W. McAbee and A. Clifford Shinkle were taken from a 1937 Delaware County, Indiana, court document found for me by Lynn McCarthy of Frankfort, Kentucky. That of James C. Gill is from Patent No. 406,041, 2 July 1889, and was sent to me by Mr. N. R. Woodward. The following signatures were provided by Bob Stahr of Saint John, Indiana, for which I thank him most sincerely. It took a lot of time to look them up for me. They are from the following sources: Samuel J. Hemingray, from Ralph Gray's will, 26 November 1863; Ralph Gray, from Patent No. 38,820, 9 June 1863; Daniel C. Hemingray, from a lease of Covington buildings to James L. Board, 6 September 1899; Ralph G. Hemingray, from Patent No. 290,771, 25 December 1883; Robert Hemingray, from Patent No. 48,399, 27 June 1865. And the following signatures appeared on a mortgage deed from Hemingray Bros. & Co. to Ralph Gray's estate (used to settle the estate), dated 15 March 1864: Joseph C. Hemingray, Richard Evans, James L. Foley, Maria G. Hemingray, Mary J. Evans, Mary E. Hemingray, and Ann Hemingray. Note: The signature of Philip W. McAbee was reduced slightly, and those of Maria Hemingray, Mary Hemingray, and Ann Hemingray were enlarged slightly to show detail. I thank everyone who helped me fulfill the idea I had to show signatures of as many people as possible.

"CD" means "Consolidated Design" number, a system invented by Mr. N. R. Woodward to identify and catalog glass insulators. The use of this term throughout the book is with permission.

Every attempt has been made by the author to find and give proper credit for all information, illustrations, and photos used herein. Any oversight has been totally unintentional.

## FORWARD

This book has been in the making since 1973, although the idea didn't crystalize until 1992. I began collecting insulators in the summer of 1972, finally settling on H. G. CO. PETTICOAT beehives by February 1973. I became curious about the "H. G. CO." embossing, so I began doing research on it. Within months I had quite a file on Hemingray. After writing several articles on the subject for Insulators--Crown Jewels of the Wire, by 1982 I still had so much unused information that I typed the rough draft for this project, not knowing that instead of another article, it would become a book.

I wrote another article, but still had information I hadn't used. I knew that if I didn't do something with this data, it would probably be lost to the insulator world when I died. The idea of writing a book flashed briefly across my mind in April 1992. I mentioned it to my sister, Arlene Inselman, who said, "You really should write a book on Hemingray with all the material you have!" When I asked my husband, Wes, he said, "You can do it. Go for it!" So because I have a sister who said I should, and a husband who knew I could, this idea became a reality, and work began in January 1996.

I have not written this book in competition with any other books on Hemingray, published or proposed. I realize that eventually there will be bigger and better efforts in this direction. With very few exceptions, I am using just that material I have gathered, taking just a few things (with permission) from other authors. This is not meant to be a comprehensive coverage of Hemingray. I won't go into the details of the insulators and other items made by them, nor will patent details be discussed at length (with the exception of the drip point patent), and other information about family history must be left out because it is just hearsay mixed with speculation, with no real proof. My purpose and hope is that the collectors and others interested in insulators (Hemingray in particular) will benefit from what I've been able to find in my (so far) 23 years of research and 24 years' experience in the hobby. I make no claim to being a Hemingray expert. This book is meant to be just plain fun to read.

This has been a labor of love, for both the hobby itself, and for the collectors who make it the joyful thing it has been for me. I hope you like reading it as much as I have enjoyed putting it together.

Clarice Gordon  
(H. G. "Bea" Hyve)  
San Diego, California  
13 October 1996



## **A FEW NOTES ABOUT THE CONTENTS OF THE BOOK**

I chose the name for this book from the two facts that Hemingray not only produced colorful items, but their history was colorful as well. The material is presented in three basic parts: "Hemingray People", "Hemingray Places", and "Hemingray Things". The three photos on the cover reflect these titles.

Part I deals mainly with the people involved with Hemingray's history. Part II includes data about their factories, homes, and final resting places. Part III is about the items they produced. While I tried not to duplicate information, it was necessary in some instances.

Wherever possible I've reproduced the original documents rather than retype them in modern style. This will give the reader a better "feel" for the particular era in which the document was written. However, in some cases the information had to be retyped because it was either too large, too small, or illegible.

The illustrations and photos in the book are not always presented at their original size, although many are. Some had to be reduced or enlarged to fit the page, or to be more easily read.

The insulators shown at the beginning of each main part are shown at actual size. I chose to portray insulators here (instead of people or factories) so that I could show them in their colors, or as close to it as paper would allow. Those insulators shown under "Some Lovely Hemingray Insulators" are at roughly one-half actual size.

I tried to present all of my information as close to fact as possible, using no speculation. If I wasn't certain of something, I didn't include it. However, opinions differ even on facts, so everyone might not agree with everything I've written. At no time was it my intention to mislead anyone or publish misinformation about Hemingray. I have checked and rechecked my sources, and I have had my manuscript read by three well-known Hemingray and insulator historians.

I apologize for any crooked lines, slanting captions, or off-center illustrations. Although I did my best to get things even, this book was done by hand by an author with astigmatism, and without the aid of a computer.

"H. G. 'Bea' Hyve" is my pen name, and was first used in October 1975. It is a play-on-words; I collect H. G. CO. PETTICOAT beehives.

TRADE MARK  
STANDARD **HEMINGRAY** INSULATORS  
REGISTERED.



# HEMINGRAY PEOPLE

## PART I



CD 241





# **HEMINGRAY PEOPLE**

## **PART I**

Just about 149 years ago, something happened in the city of Cincinnati, Ohio, that was to change many things. It changed history, it changed many people's lives, and it changed my life forever. This event didn't make national headlines, but it certainly didn't go unnoticed by thousands of people involved in any way with glass-making and eventually insulators. And when insulators became popular as collectibles many years ago, this event became important once again. What was it? It was the formation of a small glassmaking business on the east side of Hammond Street in 1848. From this small start evolved a huge glass company which made millions of insulators over a very long time. This business was to be known in time as "The Hemingray Glass Company".

It affected many lives...employees, families, customers, authors, historians, collectors, installers, dismantlers; and it has greatly affected my life. A Hemingray product was among the first 20 insulators I bought. I fell in love with its beauty, form, color, clarity. I went from collector to researcher to author. Because of that small beginning in Cincinnati, my life has been enriched beyond measure, not in monetary terms, but in the joy I've experienced collecting insulators. I want to share with you what I've learned.

So welcome to the world of Hemingray! It is my sincere wish that by the time you have read the last line in this book, you will have become better acquainted with the Hemingray name; the people, the places, and the things that they made. Theirs is a most colorful history, and although many documents and photos have been lost, those that remain show that this company had a record of which they could be proud.

This company was in business for 85 years, in three locations in three states, and was known under six names. (See next page) And all three factory sites were within a 100-mile range of one another. Although their primary interest eventually became the manufacture of insulators, they also made many other glass products, especially in their early years.

Now let's learn something about the Hemingray people, those who played both major and minor roles in the company's history. This includes the owners, their families, and employees. All played their part in the operation of the company.

Although there is some material available on the people involved in the Hemingray Glass Company, there isn't nearly as much as we'd like to have, and I regret that there are a few people for whom I wasn't able to find any data. Many questions have gone unanswered,

Company Locations, Years, and Approximate  
Number of Years at that Location  
(Years sometimes overlapped)

Hammond St. between 3rd & 4th, Cincinnati, OH.....	1848-1855.....	8
2nd & Madison Sts., Covington, KY.....	1853-1893*....	41
Macedonia Ave., Muncie, IN.....	1888-1933....	46

\* Circa

Company Names, Years, and Approximate  
Number of Years with that Name

Gray & Hemingray.....	1848-1856.....	9
Gray, Hemingray & Bros.....	1857-1860.....	4
Gray, Hemingray & Bro.....	1861-1863.....	3
Hemingray Bros & Co.....	1864-1867.....	4
R. Hemingray & Co.....	1868-1869.....	2
Hemingray Glass Co.....	1870-1933....	64

and will probably remain so indefinitely. One reason for this is the number of years that have passed since the company was in business. It has been, at this writing, 64 years since it was sold to Owens-Illinois. Another reason is that most, if not all, of the company's records were destroyed at that time, and with them went any chance of ever being able to state for a certainty exactly why or when some things were done the way they were. While we can guess at some details from what little data we have, and can make fairly accurate guesses based on surrounding data, most will probably never be known.

Not much is presently known by me about the Grays and Hemingrays before their move to Cincinnati in 1847. The Hemingray family originated in Derbyshire, England, and the Grays were also from England. From there they came across the "pond" to the Johnstown, Pennsylvania, area. The move must have been made between about 1817 and 1821, according to birth locations.

Samuel J. and Robert Hemingray were brothers, the second and third of six children born to William and Ann Johnson Hemingray. (See genealogical data beginning on page 212). William was a farmer in the vicinity of Johnstown before moving to Pittsburgh. An 1830



census lists him as being in agriculture. Samuel was born in England in 1817, and Robert was born near Johnstown in 1821. Robert was still a minor when the family moved to Pittsburgh, where William operated a general store.

In close association with the Hemingrays were the Grays. Ralph Gray was from Johnstown but was born in England in 1815; his brother Anthony was born in Pennsylvania in 1822. Robert Hemingray and Anthony Gray married sisters, Mary and Susan Carroll of Pittsburgh. There seems to have been a closer relationship between these two families than is usually found between business partners. The Hemingray and Gray brothers were very close. This close bond is also reflected in their children's names. Robert Hemingray apparently assumed responsibility for the Gray offspring after the deaths of the two Gray brothers in the early 1860s. Jobs were provided in the glassworks for at least two of the Gray sons, and Robert raised two of the Gray girls in his own home. Robert may have had some connection with glassmaking in Pittsburgh, but I have not determined for certain what his involvement was.

## CINCINNATI, OHIO

The Hemingrays and Grays came west in 1847, likely by riverboat down the Ohio River from Pittsburgh to its sister city Cincinnati. The company was formed in 1848 and was known as "Gray & Hemingray". (I have been able to find advertisements for three of the six company names; Gray & Hemingray, R. Hemingray & Co., and the Hemingray Glass Co. However, invoices do exist for Gray, Hemingray & Bros. and Hemingray Bros. & Co. Missing is any ad or invoice for Gray, Hemingray & Bro.) This small glassmaking shop was located on Hammond Street, a one-block street that ran between Third and Fourth Streets. The Hemingray and Gray families lived together in quarters quite close to the glassworks in the early years. According to Sketches and Statistics of Cincinnati in 1851, by Charles Cist, Gray & Hemingray employed 30 hands in 1851. With the exception of Samuel, who was

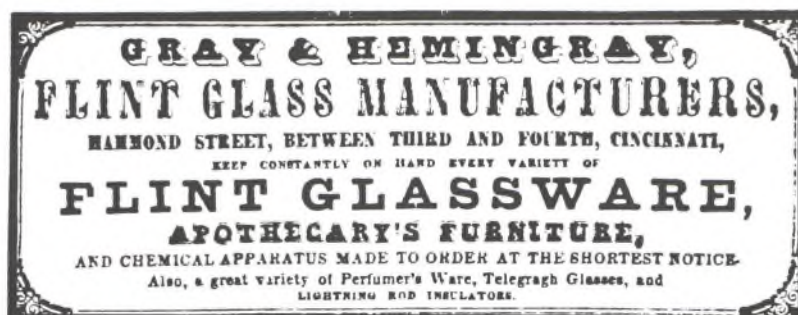

Ad for Gray & Hemingray.  
Williams' Cincinnati Directory  
& Business Advertiser  
1850-1851  
(Courtesy of Glenn Drummond)

listed as a bookkeeper in the 1853 directory, it is unknown what role each played in the early years at the glassworks, or what their official titles were, although Robert Hemingray seems to have been the one in charge. By 1859 Cist records Gray, Hemingray & Bros. (their second title) as employing 80 hands.

## **COVINGTON, KENTUCKY**

By 1853 Gray & Hemingray had transferred their business to Covington, Kentucky, across the Ohio River from Cincinnati. In 1857 Anthony Gray and Samuel Hemingray became partners with Robert Hemingray and Ralph Gray, causing the company's first name change; "Gray, Hemingray & Bros." Four years later, in 1861, it was changed again to "Gray, Hemingray & Bro.", for about this time Anthony Gray was no longer active in the business. This name lasted until Ralph Gray died in 1863, when shortly afterward Robert and Samuel Hemingray changed the name to "Hemingray Bros. & Co." The "Co." included Richard Evans and James Foley. Evans was later appointed guardian for Samuel's three children upon his death.

In September 1866 Samuel Hemingray died, and in the Covington directory we discover the fifth name, which apparently lasted for about two years; "R. Hemingray & Co.". Also listed in that year's directory is a company warehouse at 68 Walnut Street, Cincinnati. In 1870 the name was changed for the last time, when it was given its sixth name, the "Hemingray Glass Co.". This was also the year the company became a corporation.

## **MUNCIE, INDIANA**

The year 1888 saw the third and final move, to Muncie, Indiana. The company remained at this location until they sold to Owens-Illinois in 1933. This has been a brief history of the company which I felt was necessary in order to introduce some of the people. More details will be given in the next chapter. But for now, let's get better acquainted with the Hemingray people.

## **THE PEOPLE**

### **#9 SAMUEL J. HEMINGRAY**

(The numbers ahead of the names are their genealogy chart numbers. See "The Family Tree Room", page 207.)



Since his mother's maiden name was Johnson, that could be what Samuel's middle initial stood for. Samuel Hemingray was the second of six children born to #1 William and #7 Ann

Johnson Hemingray, and he was born in Heage, Derbyshire, England, on 8 May 1817. His father died in 1832 when Samuel was just 15½ years old, and although his mother lived almost another two years,



a Robert McGill was appointed his guardian by the Allegheny County Orphan's Court on 29 October 1833.

Samuel married #23 Ann (no last name known) who was from Wales, and they had three children; #24 Samuel J., #25 Henrietta M., and #26 Camilla L. They were very young when Samuel died and evidently were not taken care of by Ann, Samuel's widow, or by Samuel's brother Robert Hemingray. We don't know for certain what happened to them. #77 Richard Evans became their guardian. There is evidence that they returned to Pittsburgh.



Samuel was one of four (including Robert Hemingray, Ralph Gray, and Anthony Gray) who came west to Cincinnati in 1847, and was in on the beginnings of the company that would eventually be called "The Hemingray Glass Company". He may not have had glassmaking experience, as he was the bookkeeper for the firm. It seems that he stayed active in the company until his death on 10 September 1866 at age 49. He died of a spinal complaint in Covington, and was buried in Linden Grove Cemetery in that city. His grave has no headstone; if there ever was one, it could have been broken or stolen by vandals, as Linden Grove has been experiencing such things for many years. Samuel's wife Ann died on 16 November 1879 at age 61 of inflammation of the liver, and is buried at Newark, Ohio.

#### #10 ROBERT HEMINGRAY

Robert Hemingray, the founder of the Hemingray Glass Company, was born on 22 June 1820 near Johnstown, Pennsylvania, the third child of William and Ann Johnson Hemingray. His older brother Samuel had been born in England in 1817, so between then and when Robert was born the family made the move to the United States. Not much is known about his early life, but according



to a newspaper account in The Muncie Daily Times of 6 June 1892, he married #27 Mary Anne Carroll in Pittsburgh in early June 1842; he was about 22 years old.

The paper goes on to say that, "Since then, Mr. Hemingray has been constantly engaged in the manufacture of glass." This gives us



a hint that he no doubt left Pennsylvania in 1847 bringing some knowledge of the glassmaking business with him to Cincinnati. (See the entire article mentioned above on the following two pages.)

Robert and Mary Carroll (sister to Anthony Gray's wife Susan) had seven (possibly eight) children; #28 Camilla (Felix), #29 Anna (Shinkle), #30 Mary Ann (Shinkle), #31 Catherine (Swasey), #32 Ralph

## MARRIED FIFTY YEARS.

### THE ELABORATE CELEBRATION OF AN IMPORTANT EVENT

By Mr. and Mrs. R. Hemingray Prevented, But the Occasion is Otherwise Made Memorable by the Workmen.

Just fifty years ago in the then small village of Pittsburg, Pa., Mr. Robert Hemingray and Miss Mary Carroll were united in marriage. Since that happy event Mr. Hemingray has constantly been engaged in the manufacture of glass. For the past forty years Mr. Hemingray has conducted a flint glass factory at Covington, Ky., where he has resided until a few months ago when he moved to the magic city of the gas belt. Mr. Hemingray is one of the oldest and probably the best known glass manufacturer in the United States, and in his time has employed thousands of hands, all of whom soon learn not only to admire but love the veteran manufacturer. Some of the glass blowers now working for him in the Muncie and Covington glass factories have been in his employ many years and a great number of the young men now working in the factories are sons of men who were in his employ many years ago.

For some time the happy occasion of celebrating their golden wedding has been looked forward to with much pleasure by the family of Mr. and Mrs. Hemingray, who had planned a grand celebration, but the very serious sickness of Mrs. Ralph Hemingray, daughter-in-law, caused the original plan to be abandoned. While the immediate family had been making preparations, the employees and ex-employees of Mr. Hemingray had a surprise for the occasion and their part of the program was quietly and successfully carried Saturday evening. While the old folks were seated in quietude at their home corner of 15th and Monroe streets, at about eight o'clock a committee from the Hemingray glass factory, consisting of John

Butler, John Cramer, Mr. Bird, Mr. Doran and Mr. Murray greatly surprised Mr. and Mrs. Hemingray by calling and in behalf of the employees presented them with a silver tea set, silver napkin rings, silver smoking set, half a dozen silver spoons, a gold-headed cane and gold-headed umbrellas all appropriately engraved. Besides these Mrs. Hemingray received forty two-and-one-half-dollar gold pieces in a purse as a present from her daughter, Mrs. Bradford Shinkle, of Covington, Ky., and the three sons, Ralph, Robert and Daniel, made a delightful present of one dozen after-dinner coffee spoons. The happy groom is aged 73 and his bride but one year his junior. Since their residence in Muncie they have made many warm friends, who wish them joy in this golden age of wedded life.

Article about Mr. and Mrs. Robert Hemingray's  
50th wedding anniversary.

THE MUNCIE DAILY TIMES

6 Jun 1892

(Courtesy of the Muncie Public Library)

(Typed version on next page)



MARRIED FIFTY YEARS.

-----  
THE ELABORATE CELEBRATION OF AN IMPORTANT EVENT  
-----

By Mr. and Mrs. R. Hemingray Pre-  
vented, But the Occasion is Other-  
wise Made Memorable by the  
Workingmen.  
-----

Just fifty years ago in the then small village of Pittsburg, Pa., Mr. Robert Hemingray and Miss Mary Carroll were united in marriage. Since that happy event Mr. Hemingray has constantly been engaged in the manufacture of glass. For the past forty years Mr. Hemingray has conducted a flint glass factory at Covington, Ky., where he has resided until a few months ago when he moved to the magic city of the gas belt. Mr. Hemingray is one of the oldest and probably the best known glass manufacturer in the United States, and to this time has employed thousands of hands, all of whom soon learn not only to admire but love the veteran manufacturer. Some of the glass blowers now working for him in the Muncie and Covington glass factories have been in his employ many years and a great number of the young men now working in the factories are sons of men who were in his employ many years ago.

For some time the happy occasion of celebrating their golden wedding has been looked forward to with much pleasure by the family of Mr. and Mrs. Hemingray, who had planned a grand celebration, but the very serious sickness of Mrs. Ralph Hemingray, daughter-in-law, caused the original plan to be abandoned. While the immediate family had been making preparations, the employees and ex-employees of Mr. Hemingray had a surprise for the occasion and their part of the program was quietly and successfully carried Saturday evening. While the old folks were seated in quietude at their home corner of 15th and Monroe streets, at about eight o'clock a committee from the Hemingray glass factory, consisting of John Butler, John Cramer, Mr. Bird, Mr. Doran, and Mr. Murray greatly surprised Mr. and Mrs. Hemingray by calling and in behalf of the employees presented them with a silver tea set, silver napkin rings, silver smoking set, half a dozen silver spoons, a gold-headed cane, and gold-headed umbrella, all appropriately engraved. Besides these Mrs. Hemingray received forty two-and-one-half-dollar gold pieces-in a purse as a present from her daughter, Mrs. Bradford Shinkle, of Covington, Ky., and the three sons, Ralph, Robert and Daniel, made a delightful present of one dozen after-dinner coffee spoons. The happy groom is aged 72 and his bride but one year his junior. Since their residence in Muncie they have made many warm friends, who wish them joy in this golden age of wedded life.

\* \* \* \* \*

(Courtesy of Glenn Drummond)

Gray, #33 Robert Carroll, and #34 Daniel Carroll. (It hasn't been proven yet that #35 "Little Willie", born in October of 1864 and who died in infancy, was Robert's son.) Sometime after Ralph's birth, Robert moved their residence to Covington from Cincinnati in 1852, the year before the business was established there.

As stated in the above-mentioned newspaper article, on their 50th wedding anniversary in 1892, several company employees surprised Robert and Mary at their home at 15th and Monroe Streets in Muncie with gifts; a silver tea set, napkin rings, smoking set, six silver spoons, a gold-headed cane, and a gold-headed umbrella, all engraved.

Robert was awarded many patents over the years for various inventions. A list includes a glass jar mold, a fruit jar cap, a new design for lamp chimneys, an improvement in molding telegraph insulators (the 19 December 1871 patent), a paper perforating machine, a new design for lamp shades, a machine for flaring and crimping lamp chimneys, a glass press for the manufacture of insulators (14 June 1881), and a fastener for jar tops. (See a list of patents related to Hemingray and Owens-Illinois beginning on page 397.)

Known as "Bob" by almost everyone, he retired from active participation in the company in 1892 at about age 72, but retained his title of president. His oldest son Ralph, who was vice president, assumed executive charge. However, when fire burned the Muncie plant in June 1892, The Muncie Daily News of 18 June states, "Bob Hemingray was here at the fire, and took affairs as coolly as anyone could under the circumstances...Bob said that they would commence at once to rebuild...and as the Hemingrays have a large contract on hand for insulators for the Western Union, they can afford to lose no time."

I have been unable to find a photo of Robert, but I have heard that one exists, taken of him and his three sons at the Muncie factory in the mid-1890s. It appeared in a Muncie newspaper in the 1960s. I had hoped that it would surface before publication of this book, but so far it hasn't.

Robert Hemingray died on 27 December 1898 at age 79 at his home in Covington at 219 Garrard Street. He died of a cirrhotic kidney and cardiac hypertrophy (an enlarged heart), and cardiac exhaustion. His death was rather sudden; he had been ill for only three weeks with heart trouble. He left his widow Mary Carroll, his three sons Ralph, Robert Jr., and Daniel, and two daughters Camilla (Mrs. W. H. Felix) of Lexington, and Mary Ann (Mrs. Bradford Shinkle) of Covington. Anna J. (the first Mrs. Bradford Shinkle) had died in 1884. His funeral was held at his home, and he was buried in Highland Cemetery, three miles south of Covington at Fort Mitchell. At his death it was claimed that he was the oldest glassware manufacturer in the country. Mary Carroll Hemingray died on 27 May 1901 at the same address in Covington. She died at age 80 of chronic nephritis. She is also buried in Highland Cemetery.



Camilla married #36 the Reverend William H. Felix, who had children by a previous marriage. They had one son, #37 William H. Felix, Jr., who died in March 1918 at age 42. Her husband died in January 1912 at age 74. Camilla lived until 28 November 1933, when she died of illnesses leading to pneumonia. All three are buried in Lexington Cemetery, Lexington, Kentucky. Robert's other children will be mentioned later on in this section.

#### #32 RALPH GRAY HEMINGRAY

Robert Hemingray's three sons, Ralph, Robert Jr., and Daniel, were all active in the company. The positions they held and the dates will be covered later on. Ralph Gray Hemingray was born in Covington on 31 March 1852, the first son and fifth child of Robert and Mary Carroll Hemingray. Ralph married #54 Jane (Jennie) P. Matthews on 2 November 1875. Jennie was born in Maysville, Kentucky, around 1856. They had two daughters, #55 Llewellyn Matthews and #56 Mintie Carroll (known as Carroll). Jane, whose brother Claude Matthews became governor of Indiana, died on 2 September 1900 at Muncie, of tuberculosis at age 44. She is buried in Highland Cemetery. Ralph later married #59 Eva Hollinger. They had no children. Llewellyn died on 5 October 1942 at age 66 and is buried in Highland Cemetery. She never married. Carroll married #57 Philip McAbee; more about them later on. Eva died in Muncie on 21 February 1947 at age 64 and is buried in Woodlawn Cemetery in Terre Haute, Indiana.



Those who knew Ralph Hemingray say that he looked very much like his father. At this writing there are four known photographs of the Hemingrays (not including the one that might be of Carroll). Two of these photos are of Ralph, both taken on the same day. (They can be seen on the following pages.) He has been described by at least two contemporaries as a "short fellow who rolled his own cigarettes." Ralph was very active in civic organizations, and was well known for his generosity. Like his father, Ralph was also a prolific inventor, having received patents for a device for cleaning glass from the ends of blowpipes, a glass batch mixer, the drip point patent in conjunction with James C. Gill (2 May 1893), two glass presses, and insulating support for electric wires. (Perhaps someday some enterprising author would be willing to do a story on just the Hemingray patents, as it would make for interesting reading.)

In January 1888 he made a trip to Muncie to negotiate for the construction of the new plant to be moved from Covington, and it was probably Ralph who left Muncie shortly thereafter for Pittsburgh, to order the building materials necessary for starting the project.

When the new Muncie plant burned in June 1892, Ralph was in Covington, and was sent a wire about the tragedy. But within hours he was back in Muncie and made the statement that, "...in one hour after the [insurance] adjustors were through, they would have a force of men at work cleaning up, and the factory would be rebuilt more complete and better than before by September 1."





Ralph Gray Hemingray.  
1852-1920

Photo restored by author from his obit photo.  
The (Muncie) Morning Star  
12 May 1920





Ralph Gray Hemingray.  
From A History of Delaware County, Indiana, Vol. II,  
edited by Frank D. Haimbaugh  
1924  
(Courtesy of Ruth Crawford and the Muncie Public Library)



Ralph moved to Muncie around 1889, and became president and general manager of the company at this father's death in 1898. He, according to newspaper accounts of the time, enjoyed the same sunny disposition that all of the Hemingrays had, both men and women. They were known for their joviality, generosity, and were very well-liked by both friends and employees. (For more information on Ralph, please read the letter from Ern Parkison on page 242.)

In 1910 Ralph and Eva bought a house in Muncie at 824 E. Washington Street. This house still stands. You can read more about it beginning on page 148.

Ralph Hemingray passed away at 5:10 PM Tuesday 11 May 1920, while visiting his sister Mary Ann (Mrs. Bradford Shinkle) at her home in Covington. On the way there he developed pleurisy, but once there, he seemed to improve for a few days. However, on the day he died, he suffered a relapse. (His death certificate lists uremia as another cause of death besides pleurisy.) Ralph was 68 years old. His funeral services were held at the Shinkle home the following Thursday, and he was buried in Highland Cemetery. Many people who knew him in Muncie came to attend his funeral.

Since Ralph had no sons, upon his death his son-in-law, Philip McAbee, husband of daughter Carroll, became president and general manager of the company, and Amos C. Shinkle (I), Ralph's sister Mary's father-in-law, became vice president. The McAbees and Shinkles will rejoin our story later.

#### #33 ROBERT CARROLL HEMINGRAY, JR.

Robert Carroll Hemingray, Jr., was the second son and sixth child born to Robert and Mary Carroll Hemingray. He was born on 21 December 1854 in Covington. We don't know much about him because he was ill for a number of years and died young. He married #60 Nannie (Minnie or Anna) Taylor Timberlake and they had three children; #61 Robert (Robin) T., (or C.), Jr., #62 Conway (Con) T., and #63 Susan Ashley (Mrs. Shunim? Starr). Robert was a charter member of the Muncie Elks Lodge No. 245, organized in 1892, and Nannie was a member of the Daughters of the American Revolution. Robert fought at the front in the Spanish-American War, later spending several years at the sanatorium at College Hill, Ohio, suffering from "nervous prostration due to over work that baffled the medical experts all over the country", according to The Muncie Daily Herald, 27 July 1901. Robert had been an active member of the company until failing health forced him to retire.

Robert's wife and daughter lived in Muncie during his illness and were there when he died. His death took place on 26 July 1901, at College Hill Hospital near Cincinnati. The direct cause of death was given as "paralysis of the brain", or cerebral hemorrhage. He was 46 years old. Robert is buried in Highland Cemetery.

As for his wife Nannie, the Los Angeles City Directory for 1912 lists, "Hemingray Nannie T. Mrs. R. 5610 Ash", and for 1913, "Hemingray Nannie T. wid. Robert. r. [sic] 5692 Ash." The years 1911



through 1915 were checked but there were no listings for the other years. Nannie died in Los Angeles, California, on 12 June 1915, of breast cancer. Her address was given as 331 W. 33rd Street, having been at that location 17 days. Her obit states that she died at home. So it isn't known whether she died in a hospital at that address, or whether that was her home. (Possibly she wasn't listed in the directories after 1913 because she was a hospital patient, as she was operated on six months before her death.) Nannie was 56 when she died; she is buried in Highland Cemetery.

It is not known what became of the sons. Robin was listed in the Los Angeles City Directory for 1933, living with wife Kathy at 317 S. Olive Street. This address was in downtown Los Angeles in the area known as Bunker Hill. It isn't known if this was a business or residential address. Con was living in St. Louis in 1901, according to Gould's 1901 Directory, living at 2934 Pine, and working as a clerk at Ingersoll-Sergeant Drill Co., at 122 N. 7th. At Nannie's death in 1915, Con was the informant on her death certificate, giving his address as, "Phoenix, Ariz, Sta, C." This could have been a military base, so perhaps Con was in the army. Hopefully a future Hemingray historian will find out what eventually happened to these two sons of Robert Hemingray, Jr.

#### #34 DANIEL CARROLL HEMINGRAY

Daniel was the third son and seventh child of Robert and Mary Carroll Hemingray. He is my favorite Hemingray, and fortunately I have been able to find two photos of him, which can be seen on the following pages. Daniel was born on 4 February 1857 in Covington. We know nothing of his childhood years, but he attended Woodward High School and was a classmate of William Howard Taft, who later became president of the United States (1909-1913). (Daniel was to die during his term of office.) After attending high school, Daniel went to Chickering Preparatory School and later to the Massachusetts Institute of Technology. He apparently didn't graduate from there though, but returned to go to work in the family business.



Daniel married #64 Clara Keck, daughter of Cyrus "Sy" Keck. Clara was born in 1860 in Cincinnati. There were no children from their marriage. Daniel appears on an 1880-1881 census report for Covington where his occupation is given as "salesman", 219 Garrard, the same address as his father. By 1886-1887 he is a traveling salesman but lives at 7th and Greenup Streets. (That house still stands and can be seen on page 153.) Interestingly, James Gill lived at 734 Greenup at this same time.

Daniel continued for a time as a salesman, and as such, had much to do with the company's outside interests, and advertised the company's advantages throughout many states, and perhaps indirectly caused other businesses to locate in Muncie once the company moved there. Known by all as "Dan", he became secretary-treasurer of the



Daniel Carroll Hemingray.  
1857-1911  
Jul 1893  
(Courtesy of the Cincinnati Historical Society)





Daniel Carroll Hemingray.  
Restored by author from his obit photo.  
Photo by Bellsmith.  
The Kentucky Post  
14 Dec 1911  
(Courtesy of the Kenton County Public Library)

company in 1897 when Richard Evans died, and was also in charge of the distributing end of the company's affairs, which position he held until his death 13 years later.

Dan was very active in civic affairs, and belonged to a number of clubs and societies. Along with his duties as secretary-treasurer, he belonged to the following associations: The Cincinnati Chamber of Commerce, the Queen City Club (a private club), the Latonia Racing Association, was a director of the Suspension Bridge Company, the Cincinnati Trust Company, and the Covington Waterworks Department.

Daniel must have been a wonderfully jolly, charitable person, beloved by all. Listen to part of his obituary taken from The Kentucky Post, 15 December 1911: "'Dan' Hemingray, as he was universally known, was probably one of the best known men in the city. His jovial disposition and good fellowship was a magnet that drew about him for intimates a cluster of friends to whom his death will be a sad blow. He was always smiling and his appearance at the Queen City Club was always hailed with delight. There were no dull moments in his company and many are the Queen City members who, depressed with the cares of business, found mental rest from their worries in the optimistic, jovial and happy temperament of 'Dan' Hemingray."

On 13 December 1911 Daniel was in his car on his way home to Glendale, Ohio, from his office in Covington, when he said he felt ill and was in distress. The chauffeur was told to drive him immediately to the Queen City Club, where he was taken to a room. Doctors were summoned, and it was revealed that he'd suffered a stroke, and couldn't be moved. He was visited by numerous friends during this time. But the following morning it became apparent that the end was near. He died at 5:00 AM Thursday, 14 December 1911.

His funeral was held in Cincinnati, and was one of the largest ever held there up to that time, with many attending from various states, and many from Muncie. Burial services were held at Highland Cemetery the following Saturday.

Daniel's wife Clara lived another 32 years, and died in Christ Hospital in Cincinnati of pneumonia and congestive heart failure on 30 December 1943. She was 87 years old. Records show that she'd had a heart problem in 1930 and a stroke in 1940. The informant on her death certificate was her husband's niece, Ralph's daughter Carroll (Mrs. Philip McAbee). She was 63 at the time and had a little over three years to live. One can imagine these two old ladies, unrelated by blood but in the same family by marriage, talking about family matters. What just the two of them knew about family history would answer many questions we have today, and would fill a book several times larger than this one!

#### #11 REUBEN HEMINGRAY

Reuben Hemingray was the fourth child and third son born to William and Ann Johnson Hemingray, and was a brother of Samuel and Robert. Reuben was born on 16 June 1823, but it isn't known where, although it was probably in Pennsylvania. Reuben married #65 Caroline



(no maiden name known), who was born around 1824, and who passed away in 1866, place unknown. They had three sons; #66 Reuben P., #67 Robert B., and #68 William B. Nothing more is known about this family at this time.

#12 JOSEPH CONWAY HEMINGRAY

Joseph Conway Hemingray, fourth son and fifth child of William and Ann Johnson Hemingray, was born on 16 May 1825 in Pittsburgh. Shortly after William died in 1832, a Robert McGill and John White were appointed guardians of Joseph, his brother Reuben, and sister Mary Jane. The appointments were made by the Allegheny County Orphan's Court in 1833. Ann, their mother, was still alive, but possibly was unable to care for her six children after their father died, as she passed away the following year, in 1834.



Joseph married #69 Maria G. Hawn, who was born in Illinois in September 1839. Maria died at age 87 in Louisville, Kentucky, and is buried in Cave Hill Cemetery. Records show that she was especially fond of her granddaughter Gertrude Lamar Chambers (Donnelly), to whom she left much of her worldly goods in her will.

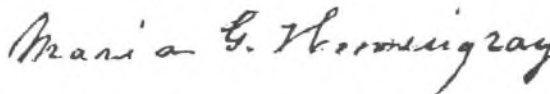

Joseph and Maria had two children; #70 Reuben P., and #71 Lillian (or Lilliene) K. Reuben married #72 Lida Blacker. Lillian married #73 Charles W. Chambers, and they had three children; #74 Reubin Hemingray, born in March 1892 in Louisville, and #75 Gertrude Lamar (Mrs. James B. Donnelly), born in June 1898 also in Louisville, and #76 Charles William, Jr., birth date and place unknown.

Joseph Hemingray was a lawyer in Louisville before moving to Leavenworth, Kansas, in the spring of 1858. That same year he was admitted to the Kansas state bar. (In those days, a judge could admit someone to the bar without their having to give proof of a high school and/or college education. One could be admitted based solely on their reputation and good name.) Joseph practiced law in Leavenworth from 1859 through 1873, having an office in various locations throughout the years. He had returned to Louisville by 1878, where on September 23 of that year he was admitted to the Kentucky state bar. Joseph passed away on 21 May 1891 in Louisville of a heart attack. He was 66 years old. He is also buried in Cave Hill Cemetery.

#77 RICHARD G. EVANS

Richard G. Evans was born in Brownsville, Pennsylvania, on 17 February 1828. In Covington on 14 November 1855 he married #13 Mary

Jane Hemingray, younger sister of Samuel and Robert, and sixth child and second daughter of William and Ann Johnson Hemingray. Richard and Mary Jane had two sons, #78 Richard G., and #79 Edgar W. (later known as W. E. Evans, secretary of the company from about 1911 through 1923). Three additional children died in infancy. When Samuel Hemingray died in 1866, Richard was appointed guardian of his three children, Samuel, Henrietta, and Camilla.

Richard was active in the company early in its history, probably as a principal stockholder. By 1870 he was vice president, but for some reason the 1880-1881 census lists him as a clerk for Hemingray. By 1882-1883 he is treasurer, and by 1888-1889, secretary-treasurer,



a post he held until his death. Richard passed away in Covington of apoplexia (stroke) on 17 January 1897 at age 68. He is buried in Highland Cemetery. (His death certificate lists

his occupation as "merchant".) After his death, his family retained his financial interests in the company.

Mary Jane was born in Pittsburgh on 26 August 1829, the second daughter and sixth child born to William and Ann Johnson Hemingray. She died in Covington on 5 July 1902 at age 72; the cause is unknown at this writing. She is buried in Highland Cemetery.

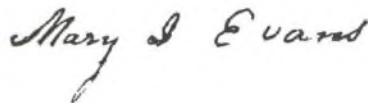

#### #52 EDWARD D. SWASEY

Edward D. Swasey was born in Cincinnati in 1848 to #48 Moses and #49 Maria R. Pack Swasey. He married #31 Kate Hemingray, fourth child and daughter of Robert and Mary Carroll Hemingray. Kate was sister to Ralph, Robert, Jr., and Daniel. The Swaseys had one daughter, #53 Mary E. Swasey (Long), born in 1871 in Covington. Mary died on 9 December 1917, age 46, in Covington, of hemorrhage.

Kate was born on 18 March 1849 in Cincinnati. She died on 3 September 1881 of typhoid fever at age 32. She and her daughter Mary are buried in Highland Cemetery. Edward remarried, and seems to have dropped out of Hemingray history. He died at age 61 on 29 January 1909 of exhaustion and enteritis. He is buried in Spring Grove Cemetery, Cincinnati.

#### #89 JAMES L. FOLEY

James L. Foley was born on 10 August 1837. He married #90 Juliet Barnes, who was born at Mt. Sterling, Kentucky, on 28 May 1841. When Ralph Gray died in 1864, Robert and Samuel Hemingray changed the company name to "Hemingray Bros. & Co.", the "Co." including Richard Evans and James Foley. Foley shows up on the Covington census in 1858, but he's not listed there again until 1864, the year he



joined the company. From 1873 until 1878, Foley was in St. Louis, Missouri, managing the company's branch office there. By 1879 neither Foley nor the Hemingray Glass Company is listed in Gould's St. Louis Business Directory. (His signature was found on a Hemingray letterhead dated 1885 dealing with the purchase of property in Chicago, but it is uncertain at this time for whom or what this property was bought.)



When the Covington plant was abandoned in 1890, Foley retired from the business. He passed away on 5 August 1910 at age 72. Juliet died on 28 June 1906 in Cincinnati. She was 65. Both are buried in Highland Cemetery.

#### #41 BRADFORD SHINKLE (I)

The Shinkles had a habit of naming their children after the previous generations, so it is not always easy to figure out about whom one is talking. I have added Roman numerals after some of the names, which should help. These numerals were not part of their names when they were alive.

During the Covington years of Hemingray, the Shinkles, Oliver, Vincent, and Amos C. (I) owned, controlled, or had a major piece of the action of just about everything in Covington. Bradford's father #39 Amos Shinkle (I) was actively involved in a number of civic ventures since arriving in the area in 1846.

Bradford Shinkle was born to #39 Amos Clifford and #40 Sarah Jane Hughes Shinkle in Higginsport, Ohio, on 29 September 1845. Like his father before him, he was active in many projects in the Covington area. He lived there almost all of his life, coming to the city with his parents in August 1846. He went to school in Covington, then attended Miami University at Oxford, Ohio, graduating from that institution. The following is a list of those titles he held: President of the Covington and Cincinnati Suspension Bridge Company, president of the Champion Ice Company, and director of the First National Bank of Covington (his father's bank), the Fifth-Third National Bank of Cincinnati, the Cincinnati Leaf Tobacco Warehouse Company, the Columbia Life Insurance Company of Cincinnati, the Central Trust & Safe Deposit Company of Cincinnati, and he was also a member of the firm of The Shinkle, Wilson & Kreis Company. He was also president of the board of trustees of the Protestant Children's Home of Covington, was a member of the Queen City Club, and the Commercial Club of Cincinnati. (The information in this paragraph was excerpted from A History of Kentucky and Kentuckians, Vol. II (1912), by E. Polk Johnson, and is courtesy of the Kenton County Public Library.)

Bradford was married twice, first to #29 Anna Johnson Hemingray, second daughter and child of Robert and Mary Carroll Hemingray.



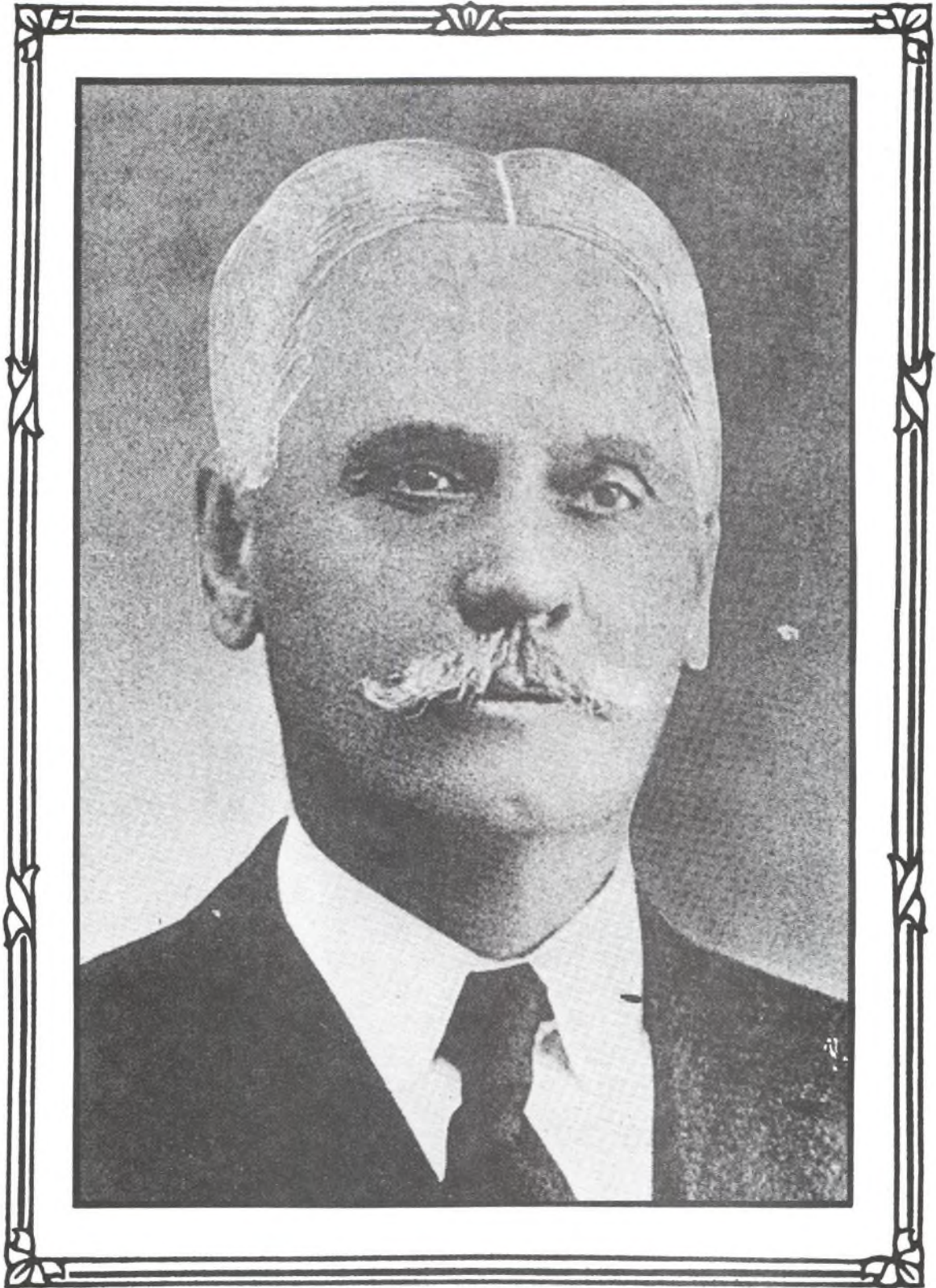

Bradford Shinkle (I)  
1845-1909

From A History of Kentucky and Kentuckians,  
by E. Polk Johnson  
1917

(Courtesy of the Kenton County Public Library)



They were married in Covington on 22 October 1868, and had two children; #42 Camilla, who married Cincinnati physician and surgeon Dr. Frank B. Cross, and #43 Amos Clifford Shinkle (II), born on 25 October 1877 in Covington. It isn't known what became of Camilla, but more will be told about Amos later on.

Anna, Bradford's first wife, was born on 18 February 1845 in Pittsburgh. She died on 1 October 1884, probably in Covington, of paralysis, at age 39. She was buried in Highland Cemetery. Bradford subsequently married #30 Mary Ann Carroll Hemingray, Anna's younger sister. Mary Ann was born on 22 February 1847 in Pennsylvania. They had one son, #47 Bradford Shinkle, Jr. (II). It isn't known what became of him, except that he was living in St. Louis in 1927 when his mother Mary Ann died. She passed away in Covington on 16 July 1927 of illnesses leading to pneumonia, at age 80. Both sisters are buried in Highland Cemetery.

After the untimely death of Robert Hemingray, Jr. in 1901, Bradford became vice president of the Hemingray Glass Company, a post he held until his own death eight years later. Bradford died at home (possibly at 165 2nd Street) in Covington, on 7 May 1909, of chronic -----? nephritis, at age 63. He is also buried in Highland Cemetery.

#### #43 AMOS CLIFFORD SHINKLE, JR. (II)

Amos Clifford Shinkle, Jr., was born in Covington on 25 October 1877, and was Bradford's son by his first wife Anna Hemingray. He married #44 Frances Hinkle (who became Frances Hinkle Shinkle...they must have had some fun with that name.) She was born in Cincinnati on 25 July 1877, to Bradford and Kate Davis Hinkle of Westerly, Rhode Island. Amos inherited the vice presidency of the Hemingray Glass Company when his father died in 1909, and he held that post at the time that Owens-Illinois took over in 1933. A. C. Shinkle, as he was generally known, was like his father and grandfather, a generous man, busy in civic affairs. A. C. and

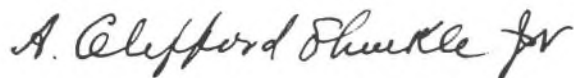

Frances had three children that we know of. #45 Amos Clifford Shinkle, Jr. (III) was born in Cincinnati on 16 May 1910. He lived at Watch Hill, Cincinnati, but died in a hospital in Westerly on 3 February 1950 of cirrhosis of the liver. (An older sister Frances died at the same hospital in 1962). Another daughter, #46 Kate Davis, was born in Westerly on 5 July 1914, passing away there on 4 October 1976.

A. C. Shinkle died at 1811 Madison Road, Cincinnati, on 4 April 1944, of pulmonary edema. He was 66 years old. Frances died in Venice, Florida, on 9 August 1951, of cancer. She was 74. Both are buried in Spring Grove Cemetery in Cincinnati.

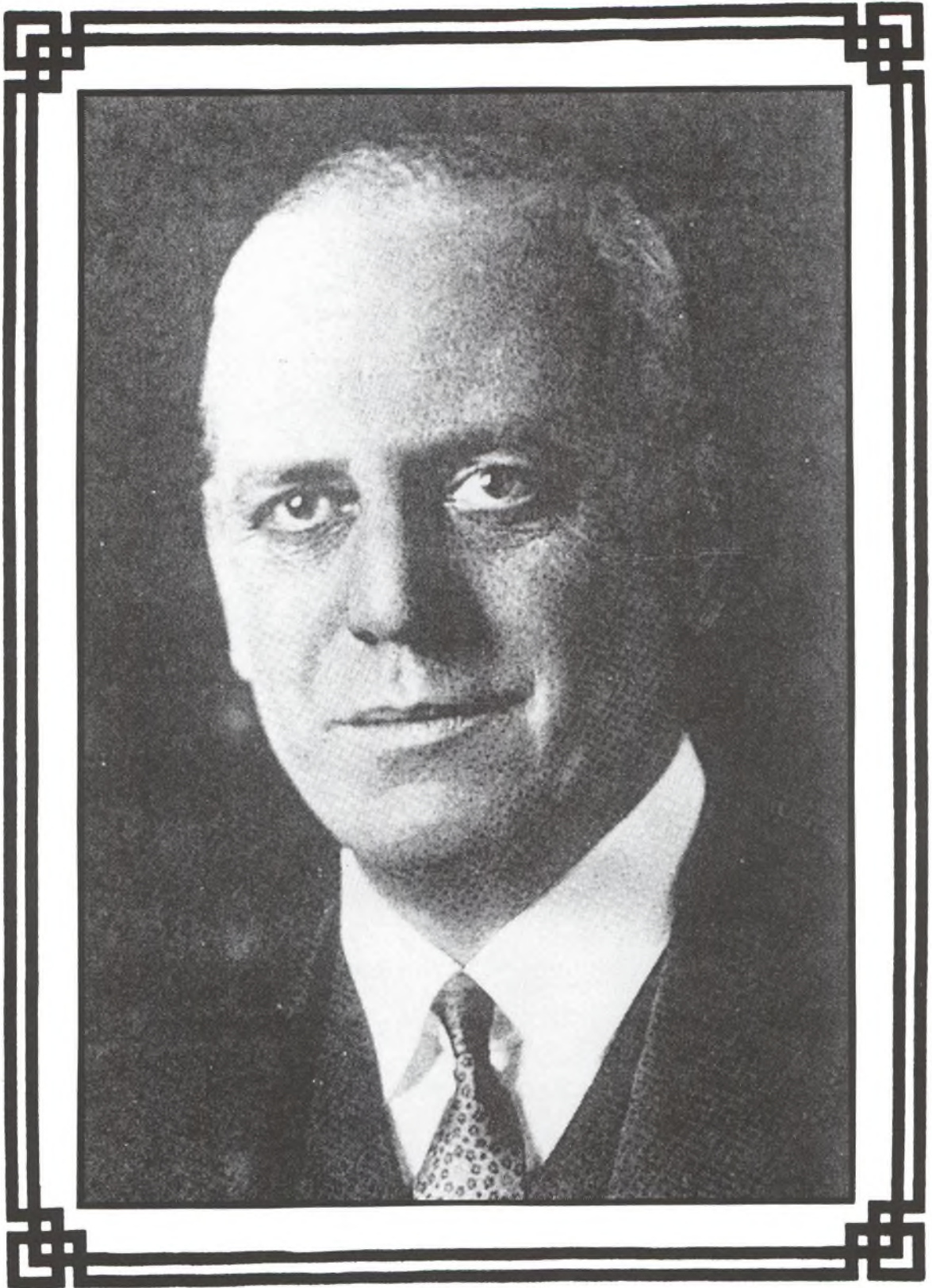

Amos Clifford Shinkle (II)  
1877-1944  
From A History of Kentucky and Kentuckians,  
by E. Polk Johnson  
1917  
(Courtesy of the Kenton County Public Library)



#57 PHILIP WARRINGTON McABEE

When Ralph Hemingray died in 1920, the position of president went to his son-in-law, daughter Carroll's husband Philip McAbee, who had been vice president since June 1919. He was president for the remainder of the company's existence and was plant manager for the first year of the Owens-Illinois ownership.

Philip McAbee was born in Cleveland, Ohio, on 22 September 1880, to Newton S. and Mary Green McAbee. His early schooling took place in Cleveland; he graduated from Phillips Academy at Andover, Massachusetts, in 1900. He worked for the Fort Smith and Western Railway in Oklahoma, then left to become affiliated with the Cleveland office of the East Ohio Gas Company, where he remained three years.

In 1904 McAbee first came to Muncie as secretary-treasurer for the Indiana Pipe Company. After four years he returned to Cleveland to work with the W. B. McAllister Company, general contractors. On 24 April 1907 he married #56 (Mintie) Carroll Hemingray of Muncie, at her home there at 411 E. Gilbert. Carroll have birth to a son, #58 Ralph Hemingray McAbee, in Cleveland in 1908; the boy lived only two years, dying there on 26 July 1910 of an "undetermined infection". (His body was removed to Beech Grove Cemetery in Muncie on 21 July 1947, shortly after Carroll died.)

Carroll apparently lived in Cleveland while Philip was in the army, or at least did so for the first few years. Philip was promoted to the rank of major eventually, sailing to France in May 1918. In 1919

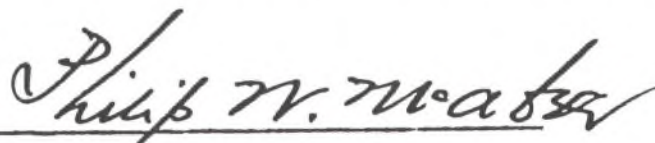

Philip W. McAbee

he came back to Muncie and returned to business, becoming involved with the Hemingray Glass Company. The following year he was given the commission of colonel in the Officers Reserve Corps.

McAbee had a lot to do with modernizing the plant. Under his direction the first automatic insulator machines with multiple molds were installed, replacing the old hand presses which only contained one mold. Because of this mechanization of the operations, production increased. So in order to continue to employ a maximum number of people, the company added a line of glass bottles in the middle 1920s, which proved to be a very successful venture for a time. And 1925 brought the first automatic container machines where glass was blown into a mold for bottles automatically instead of by hand. This new method allowed the production of more bottles per minute.

Carroll was a busy woman, belonging to many clubs in Muncie. She died at Cocoa, Florida, at age 66, of a heart attack, on 26 February 1947. She was staying at the Brevard Hotel. She is buried in Beech Grove Cemetery. (Carroll might be the mystery bride pictured on page 384 in "The 'Catch-all' Room".)



Philip W. McAbee.  
Photo from his obit.  
The Muncie Star  
8 Nov 1948

(Courtesy of the Muncie Public Library and  
Ball State Univ., A. M. Bracken Library,  
Archives & Special Collections)



After retiring from the company, McAbee lived in California for a while. He returned to Indiana, serving in various capacities and devoting much time to civic activities. He died on 7 November 1948 of a heart attack in Knoxville, Tennessee, at General Hospital. He was 68 years old. At the time of his death, his residence was listed as the Hotel Delaware in Muncie, as he had sold the home on E. Washington Street after Carroll's death. He is also buried in Beech Grove Cemetery.

Intelligent, innovative, apparently often irascible, much controversy and speculation has swirled around McAbee for years. How deeply was he involved in the changeover from Hemingray to Owens-Illinois? Did bitterness over some family matters cause him to sell out? Did he cause the changeover somehow by mismanagement? These and other rumors cannot be dealt with at this time. Certainly the Great Depression had some effect, and could have been one reason for the turning of the final page in the company's history. Philip McAbee was there and had a ringside seat, if not a part in, the end of the Hemingray Glass Company.

(This information came from several sources; my own research, and Rosella Cartwright, who sent material from Indiana Today, the Muncie section of which was edited by Wilbur Sutton, 1942.)

#### #80 RALPH GRAY

Ralph Gray was born in England in 1815. He immigrated to the United States, settling in Pennsylvania. Ralph married #81 Ann Friar, who was born on 16 October 1812 in Ireland. We know of no children from this marriage. In 1847 Ralph came with Samuel and Robert Hemingray and his brother Anthony to Cincinnati, and he was one of the four who were in on the founding of Gray & Hemingray. (Robert's son Ralph Gray Hemingray was named after Ralph Gray.) He moved his residence from Cincinnati to Covington in 1855, and was listed in the city directory for the last time in 1863. He passed away on 20 November 1863 at age 48, of an abscess of the liver. Ann died on 27 October 1902 in Covington of cerebral hemorrhage; she was 90. Both she and Ralph are buried in Spring Grove Cemetery. (Records show that Ralph had been buried first in Linden Grove Cemetery, but later removed to Spring Grove in December 1899.)

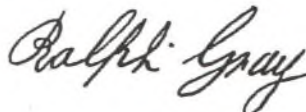

#### #82 ANTHONY GRAY

Anthony Gray was born in Pennsylvania in 1822, and married #83 Susan Carroll, born around 1828 in Pittsburgh. Susan's sister Mary was Robert Hemingray (Sr.'s) wife. They had four children; #84 Elizabeth, born in Ohio around 1850, #85 John C., born around 1855 in Kentucky, #86 Anna, born around 1857 in Kentucky, and #87 Catherine, born around 1860 also in Kentucky. Ralph Gray, #88, has not been proven to be their son.

Anthony was one of the original members who established Gray

& Hemingray. But in 1861 he left Hemingray and went to work for Thomas Bagley & Co. The reason is unknown. When Anthony died at age 43 on 27 April 1865, Robert Hemingray apparently took the children into his home, at least two of the girls, and assumed responsibility later on for the boys by finding jobs for them at the company. The John C. Gray who was manager in the early part of this century was no doubt Anthony's son. Susan died on 19 August 1866 at about age 39. Both she and Anthony are buried in Linden Grove Cemetery.

#### JAMES C. GILL

James C. Gill was born in Wheeling, West Virginia, in 1832. In about 1877 he was made foreman in the mold shop at Covington, and moved to Muncie in 1890 continuing in that capacity. But it is for his work along with Ralph G. Hemingray on the 1893 drip point patent that Mr. Gill will be long remembered, at least in insulator circles. The drip points, located on the bottom (resting surface) of the base of the insulator, were supposed to "take all the moisture from the inner and outer surface of the insulator and keep the pin dry", according to a turn-of-the-century company ad. These drip points, although not unique to Hemingray in the long run, were to become a Hemingray trademark of sorts. (Mr. Gill had recorded four previous patents relating to the manufacture of glassware, beginning in 1875.)



James Gill had two children, May and James, who were with their father, along with his wife, when he died in Muncie at age 70, on 17 January 1902. He was buried in Spring Grove Cemetery. (For more information on drip points, see pages 174 and 395.)

#### WILLARD PAUL ZIMMERMAN

W. P. Zimmerman started with the Hemingray Glass Co. in 1921, and in later years became a salesman and secretary/treasurer. On 2 June 1931 he received Design Patent 84,313 for a bottle design and assigned it to Hemingray. After O-I ownership, Mr. Zimmerman continued as manager of the plant. During this time he received several patents regarding glass block products, and assigned them to Owens-Illinois.

---

There might be some descendants of the Hemingrays, Grays, Shinkles, McAbees, or others mentioned herein still living. If any of you read this book, please contact me at the address on the verso page. I'd love to hear from you!



# Muncie Personalities

Series of Pen Portraits by Col. Jack Moranz, Depicting Background and Lives of Prominent Citizens of Muncie and Vicinity.)

PLAYED FOOTBALL AT COLLEGE • HIS HOBBIES ARE FOOTBALL AND GOLF • MEMBER MASON'S, KIWANIS, B. of C., COLUMBIAN CLUB (INDIANAPOLIS), D-K-E OF NEW YORK AND PAN-AMERICAN SOCIETY •

HIS BOYHOOD AMBITION WAS TO BE A SOLDIER • SERVED OVERSEAS AS REGIMENTAL ADJUTANT 330 INF. 83<sup>RD</sup> OHIO DIV. AND AFTER THE WAR WENT WITH AMERICAN SEEDING-MACHINE CO AT SPRINGFIELD, OHIO •

FIRST JOB ON HIS FATHER'S FARM • BORN AT WASHINGTON COURT HOUSE, OHIO • GRADUATE OF MIAMI UNIVERSITY, OXFORD, O. HE MARRIED RUTH MEEBY; HAS 2 CHILDREN, JEAN AND PAUL JR. •

HE IS MANAGER OF THE MUNICIE PRESSED WIRE DIVISION OF OWENS-ILLINOIS GLASS CO. • MAKERS OF INSULUX AND INSULATORS • CAME TO MUNICIE IN 1921 AND STARTED WITH THE HEMINGRAY GLASS CO. • HE SUBSEQUENTLY BECAME A SALESMAN AND SECRETARY-TREASURER • WHEN THE FIRM WAS PURCHASED BY OWENS-ILLINOIS, HE BECAME ASST. MGR. THEN MGR. •

W. P. Zimmerman

— FROM NEISHWANGER PHOTO —

This is the fifteenth in a series of sketches depicting business and professional leaders of Muncie and vicinity to appear daily in The Star. They are drawn by Col. Jack Moranz, internationally known portrait artist and cartoonist.

The Muncie Morning Star  
24 January 1936  
(Courtesy of the Muncie Public Library)



POSITIONS HELD BY VARIOUS PEOPLE AT HEMINGRAY AT VARIOUS TIMES,  
1848-1933

(Data taken from letterheads, histories, city directories, obits, biographies, and other sources. Entries appearing to be in error will be shown in brackets, as will explanations. This information courtesy of Glenn Drummond, Bob Stahr, Dick Roller, the Cincinnati Historical Society, and the Muncie Public Library.)

1848-1850

Robert Hemingray, founder, senior partner  
Ralph Gray, partner

1851

Robert Hemingray, senior partner  
Ralph Gray, partner  
Samuel Hemingray, clerk

1852-1855

Robert Hemingray, senior partner  
Ralph Gray, partner  
Anthony Gray, partner  
Samuel Hemingray, bookkeeper

1856

Robert Hemingray, senior partner  
Ralph Gray, partner  
Anthony Gray, partner  
Samuel Hemingray, clerk

1857-1859

Robert Hemingray, principal partner  
Ralph Gray, partner  
Anthony Gray, partner  
Samuel Hemingray, bookkeeper

1860

Robert Hemingray, principal partner  
Ralph Gray, partner  
Anthony Gray, partner  
Samuel Hemingray, bookkeeper  
Richard Evans, clerk  
James A. S. Gray, clerk [a brother of Ralph and Anthony]  
[Daniel Hemingray, brick mason. Not "our" Daniel, who would have been around 3 years old.]

1861

Robert Hemingray, principal partner  
Ralph Gray, partner  
[Anthony Gray, Thomas Bagley & Co. Reason for job change unknown.]  
Samuel Hemingray, bookkeeper  
Richard Evans, clerk  
James A. S. Gray, clerk

1862

Robert Hemingray, principal partner  
Ralph Gray, partner  
Samuel Hemingray, bookkeeper  
Richard Evans, clerk  
James A. S. Gray, clerk



1863

Robert Hemingray, principal partner  
Ralph Gray, partner  
Samuel Hemingray, bookkeeper  
Richard Evans, bookkeeper  
James A. S. Gray, clerk

1864-1866

Robert Hemingray, principal partner  
Samuel Hemingray, bookkeeper  
James L. Foley, principal stockholder  
Richard Evans, clerk  
James A. S. Gray, clerk  
J. C. Hemingray [No title. Joseph C., a brother of Robert.]

1867-1869

Robert Hemingray, principal partner  
James L. Foley, principal stockholder  
Richard Evans, clerk  
James A. S. Gray, clerk  
J. C. Hemingray [no title]

1870 [year of incorporation]

Robert Hemingray, president  
Richard Evans, vice president  
James L. Foley, principal stockholder  
Edward D. Swasey, clerk

1871-1872

Robert Hemingray, president  
James L. Foley, vice president  
Richard Evans, secretary  
Edward D. Swasey, clerk/bookkeeper

1873

Robert Hemingray, president  
Richard Evans, vice president  
Edward D. Swasey, secretary  
James L. Foley, St. Louis branch manager  
Daniel Hemingray, manager

1874

Robert Hemingray, president  
Richard Evans, vice president  
Edward D. Swasey, secretary/treasurer  
James L. Foley, St. Louis branch manager  
Daniel Hemingray, manager  
Ralph Hemingray, superintendent

1875-1876

Robert Hemingray, president  
Richard Evans, vice president  
Edward D. Swasey, secretary/treasurer  
James L. Foley, St. Louis branch manager  
Daniel Hemingray, manager  
Ralph Hemingray, superintendent  
John C. Gray, clerk [son of Anthony Gray]  
Robert C. Gray, clerk [son of James Gray]

1877

Robert Hemingray, president  
Richard Evans, vice president

1877 continued

Edward D. Swasey, secretary/treasurer  
James L. Foley, St. Louis branch manager  
Ralph Hemingray, superintendent  
John C. Gray, clerk  
Robert C. Gray, clerk  
Daniel Hemingray, clerk

1878-1879

Robert Hemingray, president  
Richard Evans, vice president  
Edward D. Swasey, secretary/treasurer  
Ralph Hemingray, superintendent  
John C. Gray, clerk  
Robert C. Gray, clerk  
Daniel Hemingray, salesman

1880

Robert Hemingray, president  
Ralph Hemingray, vice president  
Richard Evans, treasurer  
Edward D. Swasey, secretary  
John C. Gray, clerk  
Robert C. Gray, clerk  
Robert C. Hemingray, clerk  
Daniel Hemingray, salesman

1881

Robert Hemingray, president  
Ralph Hemingray, vice president  
Richard Evans, secretary/treasurer  
John C. Gray, clerk  
Robert C. Gray, clerk  
Robert C. Hemingray, clerk  
Daniel Hemingray, salesman

1882-1883

Robert Hemingray, president  
Ralph Hemingray, vice president  
Richard Evans, treasurer  
Richard G. Evans, clerk [son of Richard Evans]  
John C. Gray, entry clerk  
Robert C. Gray, clerk  
Daniel Hemingray, manager  
Robert C. Hemingray, superintendent  
James C. Gill, moldmaker

1884-1885

Robert Hemingray, president  
Ralph Hemingray, vice president  
Richard Evans, treasurer  
Richard G. Evans, bookkeeper  
James L. Foley, traveling salesman  
John C. Gray, entry clerk  
Ralph Gray, clerk [possibly a son of Anthony Gray]  
Robert C. Gray, shipping clerk  
Daniel Hemingray, manager  
Robert C. Hemingray, superintendent  
James C. Gill, glass moldmaker



1886-1887

Robert Hemingray, president  
Ralph Hemingray, vice president  
Richard Evans, treasurer  
Richard G. Evans, bookkeeper  
James L. Foley, traveling salesman  
John C. Gray, clerk  
Ralph Gray, clerk  
Robert C. Gray, shipping clerk  
Daniel Hemingray, manager  
Robert C. Hemingray, superintendent  
James C. Gill, foreman moldmaker

1888-1889

Robert Hemingray, president  
Ralph Hemingray, vice president  
Richard Evans, secretary/treasurer  
Richard G. Evans, bookkeeper  
James L. Foley, traveling salesman  
John C. Gray, entry clerk  
Ralph Gray, clerk  
Robert C. Gray, shipping clerk  
Daniel Hemingray, manager  
Robert C. Hemingray, superintendent  
James C. Gill, foreman mold shop

1890-1891

Robert Hemingray, president  
Ralph Hemingray, vice president  
Richard Evans, secretary/treasurer  
Richard G. Evans, bookkeeper  
John C. Gray, entry clerk  
[Ralph Gray, IRS agent. Reason for job change unknown.]  
Robert C. Gray, shipping clerk  
Daniel Hemingray, salesman  
Robert C. Hemingray, superintendent  
James C. Gill, glass moldmaker

1892-1894

Robert Hemingray, president [retired]  
Ralph Hemingray, vice president [acting president]  
Richard Evans, secretary/treasurer  
John C. Gray, entry clerk  
Daniel Hemingray, traveling salesman  
Robert C. Hemingray, superintendent

1895-1896

Robert Hemingray, president [retired]  
Ralph Hemingray, vice president [acting president]  
Richard Evans, secretary/treasurer  
Robert C. Gray, clerk  
W. Edgar Evans, clerk [also listed as Wm. E. Evans]  
Daniel Hemingray, traveling salesman

1897

Robert Hemingray, president [retired]  
Ralph Hemingray, vice president [acting president]  
Daniel Hemingray, secretary

1897 continued  
 Richard Evans, treasurer  
 Robert C. Gray, clerk  
 W. Edgar Evans, clerk  
 John C. Gray, superintendent

1898-1899  
 Ralph Hemingray, president  
 Robert C. Hemingray, vice president  
 Daniel Hemingray, secretary/treasurer  
 Robert C. Gray, clerk  
 W. Edgar Evans, cashier  
 John C. Gray, superintendent

1900-1901  
 Ralph Hemingray, president  
 Bradford Shinkle, vice president  
 Daniel Hemingray, secretary/treasurer  
 Robert C. Gray, clerk  
 W. Edgar Evans, bookkeeper

1902-1903  
 Ralph Hemingray, president  
 Bradford Shinkle, vice president  
 Daniel Hemingray, secretary/treasurer  
 Robert C. Gray, salesman  
 W. Edgar Evans, bookkeeper

1904-1905  
 Ralph Hemingray, president  
 Bradford Shinkle, vice president  
 Daniel Hemingray, secretary/treasurer  
 Robert C. Gray, salesman  
 W. Edgar Evans, cashier

1906-1907  
 Ralph Hemingray, president  
 Bradford Shinkle, vice president  
 Daniel Hemingray, secretary/treasurer  
 Robert C. Gray, salesman  
 W. Edgar Evans, assistant treasurer

1908  
 Ralph Hemingray, president  
 Bradford Shinkle, vice president  
 Daniel Hemingray, secretary/treasurer  
 W. Edgar Evans, bookkeeper

1909-1911  
 Ralph Hemingray, president  
 W. Edgar Evans, vice president  
 Amos C. Shinkle, vice president [later in 1909]  
 Daniel Hemingray, secretary/treasurer

1912-1914  
 Ralph Hemingray, president  
 Amos C. Shinkle, vice president  
 W. Edgar Evans, secretary/treasurer  
 John C. Gray, manager

1915-1918  
 Ralph Hemingray, president



1915-1918 continued

Amos C. Shinkle, vice president  
W. Edgar Evans, secretary/treasurer  
James C. Bartling, manager

1919-1920

Ralph Hemingray, president  
Amos C. Shinkle, vice president  
W. Edgar Evans, secretary  
Charles S. Berger, treasurer  
James C. Bartling, manager

1920 [later in year]

Philip McAbee, president  
Amos C. Shinkle, vice president  
W. Edgar Evans, secretary  
Charles S. Berger, treasurer  
Carl H. Smith, office manager

1921-1923

Philip W. McAbee, president  
Amos C. Shinkle, vice president  
W. Edgar Evans, secretary  
Willard P. Zimmerman, assistant secretary and sales agent  
Charles S. Berger, treasurer  
Carl H. Smith, assistant treasurer and purchasing agent

1924

Philip McAbee, president  
Amos C. Shinkle, vice president  
W. Edgar Evans, secretary  
Charles S. Berger, treasurer  
Carl H. Smith, assistant treasurer

1925-1926

Philip McAbee, president  
Amos C. Shinkle, vice president  
Willard P. Zimmerman, secretary  
Harley T. Campbell, assistant secretary  
Charles S. Berger, treasurer  
Carl H. Smith, assistant treasurer and purchasing agent  
Fred J. Lesh, auditor  
Minot K. Holmes, chemist and engineer  
M. J. Clark, factory manager

1927-1928

Philip McAbee, president and general manager  
Amos C. Shinkle, vice president  
Willard P. Zimmerman, secretary  
Harley T. Campbell, assistant secretary  
Carl H. Smith, assistant treasurer  
Fred J. Lesh, auditor

1929-1930

Philip McAbee, president  
Amos C. Shinkle, vice president  
Willard P. Zimmerman, secretary/treasurer  
Harley T. Campbell, assistant secretary  
Carl H. Smith, assistant treasurer and purchasing agent  
Fred J. Lesh, auditor

1931-1933

Philip McAbee, president

1931-1933 continued

Amos C. Shinkle, vice president  
Willard P. Zimmerman, secretary/treasurer  
Carl H. Smith, assistant treasurer and purchasing agent  
Fred J. Lesh, auditor

Note: Year groups change when there was a change in personnel and/or position. Sometimes the same position was called by different names, such as Samuel Hemingray's title changing back and forth from clerk to bookkeeper in the 1850s. A new year group was made for every change noted in our research, no matter how insignificant.

Names were sometimes carried over on letterheads a year or longer after the position was vacated. Also, positions changed mostly during the year, not at the very end or beginning, so they often overlapped. In addition, names were probably inadvertently omitted from some sources. For this reason I have relied mostly on information taken from city directories, as it is probably the most accurate. I make no claim that this list is perfect. It is just a guide.

A big thank you to Bob Stahr, who checked and rechecked this list, and whose attention to detail made it as accurate as possible.

**HEMINGRAY**  
**GLASS**  
**INSULATORS**

The transparency of Hemingray Glass Insulators makes line inspection very simple. The lineman can tell at a glance whether the insulator is intact or not. Hemingray insulators are mechanically and dielectrically dependable, non-porous and uniform in structure. They defy moisture and age.

*Send for Bulletin No. 1.*

**HEMINGRAY GLASS COMPANY**  
**Muncie, Indiana**

Company ad.  
Journal of the American Institute of Electrical Engineers  
Apr 1930  
(Courtesy of Elton Gish)



## WHERE THE PEOPLE ARE BURIED

The majority of the Hemingrays are buried in Highland Cemetery near Fort Mitchell, Kentucky, about three miles south of downtown Covington. The town was a small fort during the Civil War built for the protection of Covington and Cincinnati, but never saw any action because the war didn't come near there.

There's a family plot located at the east end of Section 9. At the center of the graves is a large pointed monument on a one-foot-high base, about 30 feet high, with the name "HEMINGRAY" on it. The graves around the monument face east, and are on all four sides from the big monument. The names are engraved on each small gray granite headstone in a style reminiscent of the embossings on Hemingray No. 9 insulators of about 1895. The Shinkle family plot is also located in Highland Cemetery (see map on page 40), although some Shinkles are buried in Spring Grove Cemetery in Cincinnati.

Linden Grove Cemetery is also in Covington, where other people important to the Hemingray story are buried. Anthony Gray and wife Susan are there along with Samuel Hemingray, in Range X Lot 48 (see map on page 48). There is no tombstone, marker, or any sign of Samuel's grave in this lot. The other markers for Anthony and Susan are of white marble and are about two feet wide, one foot high, and about seven inches thick, and face west. The names are worn down from the weather. The front and back don't have anything on them now, but at one time may have had the birth and death dates on them.

There could be several reasons why Samuel's grave is unmarked. Although I have been unable to find any records, the Hemingray family could have moved him to Highland or some other cemetery in the area. Many other families have done that. Franklin Jaquish tells me, "Kids get in the cemetery every night from over the fence...and just knock over or break tombstones by throwing the smaller ones on top of others to break them, or just scatter them around where they don't belong. They also dig up the graves and throw the skulls and bones around everywhere. Samuel Hemingray might have had a tombstone that was broken or taken away by vandals years ago...The caretakers...take care of the cemetery for the owners as best they can, but they can't watch over all of it all of the time."

One of the mysteries I wanted to solve before my book was published was to find out if Samuel Hemingray was in fact still in Linden Grove, and if so, where. And if not, to where was he moved? All of these records are somewhere; I just ran out of time to pursue this matter any further.

Following is a list of the main players in our story along with the places where they are buried. Their genealogy chart numbers are also given. Following this list are maps of Highland and Linden Grove, followed by photos of some of the headstones.

WHERE THE PEOPLE ARE BURIED  
(CEMETERY, CITY, STATE)  
(NUMBERS ARE THEIR GENEALOGY CHART NUMBERS)

1. William Hemingray	Allegheny	Pittsburgh	PA
2. Mariah Barlow (Hemingray)			Eng.
3. George Hemingray	Allegheny	Pittsburgh	PA
4. William Hemingray, Jr.		Pittsburgh	PA
5. Harriett (Hemingray)	?	?	?
6. Georgeanna Hemingray	?	?	?
7. Ann Johnson (Hemingray)	Allegheny	Pittsburgh	PA
8. Catherine Hemingray (Horner)	Allegheny	Pittsburgh	PA
9. Samuel J. Hemingray	Linden Grove	Covington	KY
10. Robert Hemingray	Highland	Covington	KY
11. Reuben Hemingray	?	?	?
12. Joseph C. Hemingray	Cave Hill	Louisville	KY
13. Mary J. Hemingray (Evans)	Highland	Covington	KY
14. Charles Horner, Jr.	Allegheny	Pittsburgh	PA
15. Ann E. Horner	?	?	?
16. Robert H. Horner	?	?	?
17. Mary A. Horner	?	?	?
18. Catherine E. Horner	?	?	?
19. Charles M. Horner	?	?	?
20. Harriet B. Horner	?	?	?
21. William C. Horner	?	?	?
22. Calantha Horner	?	?	?
23. Ann (Hemingray)	?	Newark	OH
24. Samuel J. Hemingray	?	?	?
25. Henrietta M. Hemingray	?	?	?
26. Camilla L. Hemingray	?	?	?
27. Mary A. Carroll (Hemingray)	Highland	Covington	KY
28. Camilla Hemingray (Felix)	Lexington	Lexington	KY
29. Anna J. Hemingray (Shinkle)	Highland	Covington	KY
30. Mary Ann C. Hemingray (Shinkle)	Highland	Covington	KY
31. Catherine Hemingray (Swasey)	Highland	Covington	KY
32. Ralph G. Hemingray	Highland	Covington	KY
33. Robert C. Hemingray, Jr.	Highland	Covington	KY
34. Daniel C. Hemingray	Highland	Covington	KY
35. "Little Willie" Hemingray	Highland	Covington	KY
36. William H. Felix	Lexington	Lexington	KY
37. William H. Felix, Jr.	Lexington	Lexington	KY
38. Annie B. Felix	?	?	?
39. Amos C. Shinkle (I)	Highland	Covington	KY
40. Sarah J. Hughes (Shinkle)	Highland	Covington	KY
41. Bradford Shinkle (I)	Highland	Covington	KY
42. Camilla Shinkle (Cross)	?	?	?
43. Amos C. Shinkle (II)	Spring Grove	Cincinnati	OH
44. Frances Hinkle (Shinkle)	Spring Grove	Cincinnati	OH
45. Amos C. Shinkle, Jr. (III)	?	?	?
46. Kate D. Shinkle	?	?	?
47. Bradford Shinkle, Jr. (II)	?	?	?
48. Moses Swasey	?	?	?
49. Maria R. Pack (Swasey)	Spring Grove	Cincinnati	OH
50. William H. Swasey	?	?	?



51. Ella M. Swasey	?	?	?
52. Edward D. Swasey	Spring Grove	Cincinnati	OH
53. Mary E. Swasey (Long)	Highland	Covington	KY
54. Jane P. Matthews (Hemingray)	Highland	Covington	KY
55. Llewellyn M. Hemingray	Highland	Covington	KY
56. M. Carroll Hemingray (McAbee)	Beech Grove	Muncie	IN
57. Philip W. McAbee	Beech Grove	Muncie	IN
58. Ralph H. McAbee	Beech Grove	Muncie	IN
59. Eva Hollinger (Hemingray)	Woodlawn	Terre Haute	IN
60. Nannie Timberlake (Hemingray)	Highland	Covington	KY
61. Robert C. Hemingray, Jr.	?	?	?
62. Conway T. Hemingray	?	?	?
63. Susan A. Hemingray (Starr)	?	?	?
64. Clara Keck (Hemingray)	Highland	Covington	KY
65. Caroline (Hemingray)	?	?	?
66. Reuben P. Hemingray	?	?	?
67. Robert B. Hemingray	?	?	?
68. William B. Hemingray	?	?	?
69. Maria G. Hawn (Hemingray)	Cave Hill	Louisville	KY
70. Reuben P. Hemingray	?	?	?
71. Lillian K. Hemingray (Chambers)	?	?	?
72. Lida Blacker (Hemingray)	?	?	?
73. Charles W. Chambers	?	?	?
74. Reubin H. Chambers	?	?	?
75. Gertrude L. Chambers (Donnelly)	?	?	?
76. Charles W. Chambers, Jr.	?	?	?
77. Richard G. Evans	Highland	Covington	KY
78. Richard G. Evans	?	?	?
79. Edgar W. Evans	?	?	?
80. Ralph Gray	Spring Grove	Cincinnati	OH
81. Ann Friar (Gray)	Spring Grove	Cincinnati	OH
82. Anthony Gray	Linden Grove	Covington	KY
83. Susan Carroll (Gray)	Linden Grove	Covington	KY
84. Elizabeth Gray	?	?	?
85. John C. Gray	?	?	?
86. Anna Gray	?	?	?
87. Catherine Gray	?	?	?
88. Ralph Gray?	?	?	?
89. James L. Foley	Highland	Covington	KY
90. Juliet Barnes (Foley)	Highland	Covington	KY

Note: In some cases I know where the person died, but I did not assume that they were buried in that city. Recorded here are just those burial places of people that have been confirmed by myself or another researcher.

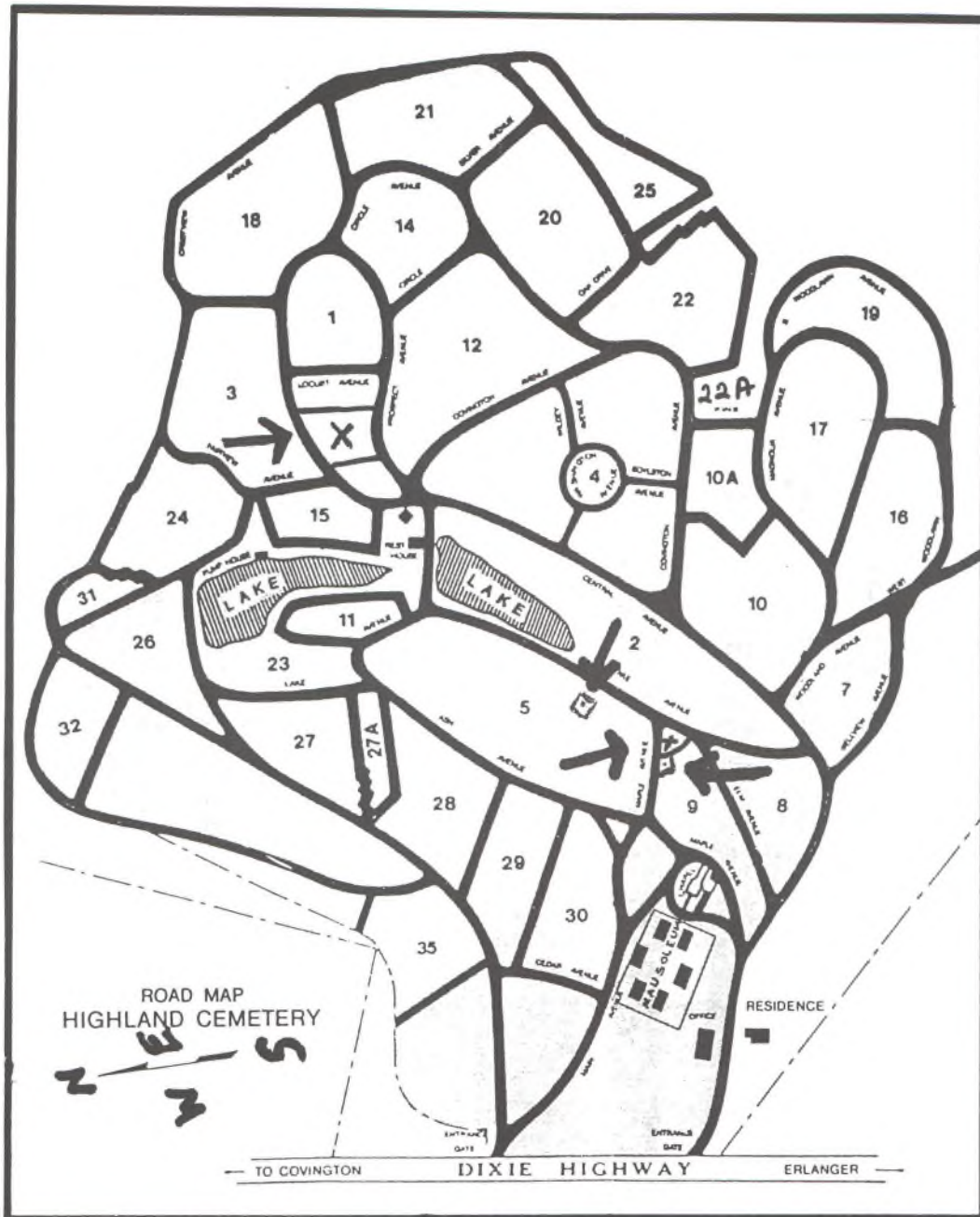

Map of Highland Cemetery, Ft. Mitchell, KY  
 (Top arrow, Shinkle plot, middle arrow, Chambers (of insulator fame) plot, lower left arrow, Hemingray plot, lower right arrow, Evans plot)  
 (Map and location of Shinkle and Hemingray plots courtesy of Rebecca Haake. Location of Chambers and Evans plots courtesy of Bob Stahr)



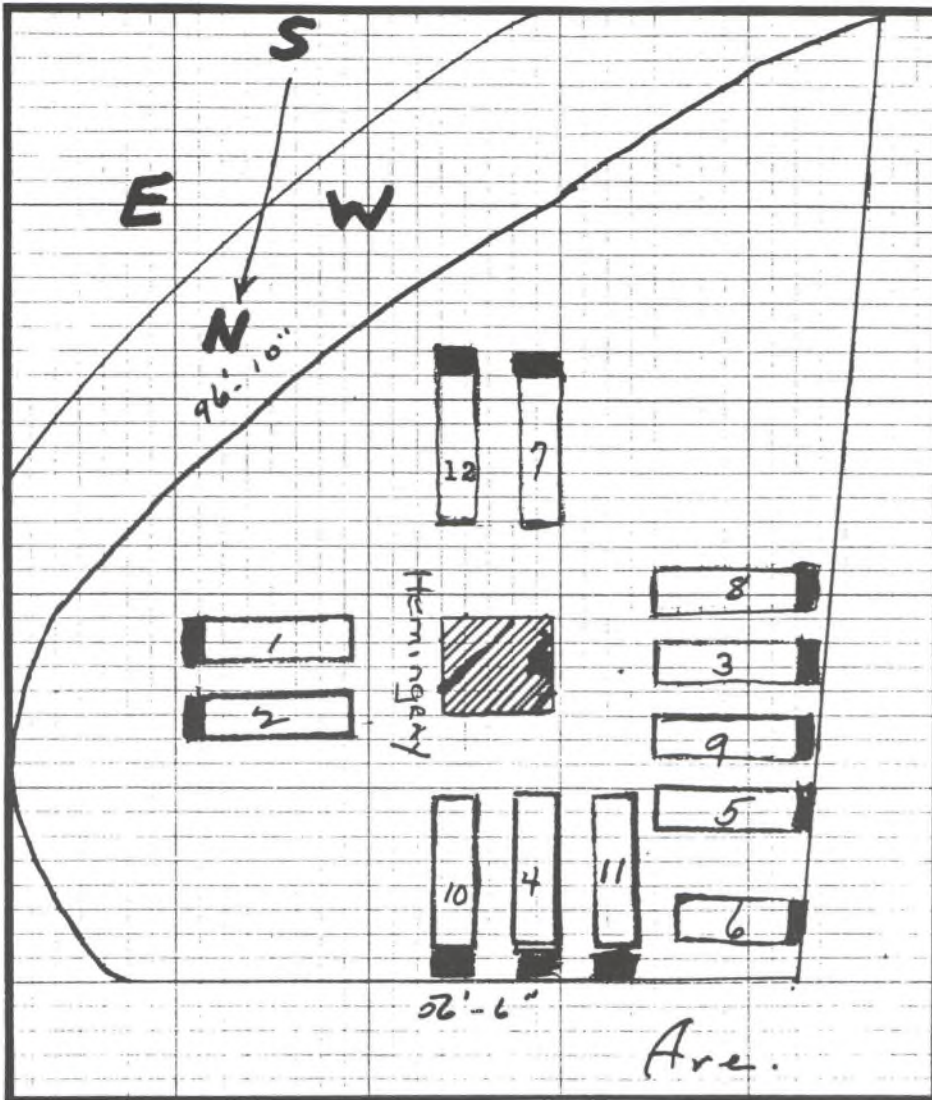

Close-up of Hemingray plot.  
(Courtesy of Rebecca Haake)

- |                              |                         |
|------------------------------|-------------------------|
| 1. Robert Hemingray          | 7. Daniel C. Hemingray  |
| 2. Mary C. Hemingray         | 8. Nannie T. Hemingray  |
| 3. Robert C. Hemingray       | 9. Mary S. Long         |
| 4. Jennie Matthews Hemingray | 10. Ralph G. Hemingray  |
| 5. Kate Hemingray Swasey     | 11. Llewellyn Hemingray |
| 6. "Little Willie" Hemingray | 12. Clara Hemingray     |

Section 9 Lot 4 Deed No. 440 3360 Sq. Ft. 19 Dec. 1881 \$810.00

Names and numbers corresponding to map.  
(Courtesy of Franklin Jaquish and Rebecca Haake)



Long view of the Hemingray monument.  
Covington (Fort Mitchell), KY  
Looking west.  
Jun 1983  
(Courtesy of Franklin Jaquish)

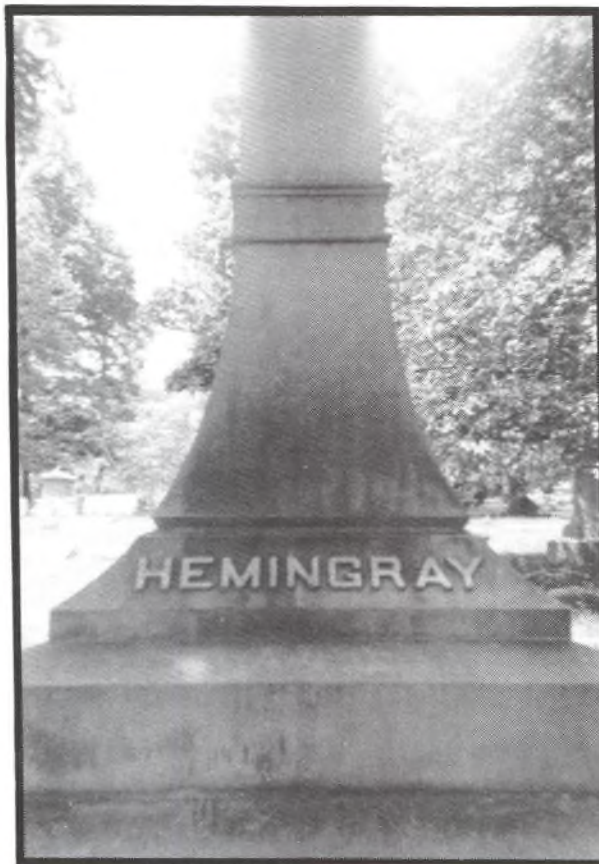

Close-up of Hemingray monument, looking west.  
Jun 1983  
(Courtesy of Franklin Jaquish)





Grave of Robert Hemingray.  
Highland Cemetery, Covington, KY  
Jun 1983  
(Courtesy of Franklin Jaquish)



Grave of Robert C. Hemingray.  
Highland Cemetery, Covington, KY  
Jun 1983  
(Courtesy of Franklin Jaquish)



Grave of Daniel C. Hemingray.  
Highland Cemetery, Covington, KY  
Jun 1983  
(Courtesy of Franklin Jaquish)



Grave of Ralph G. Hemingray.  
Highland Cemetery, Covington, KY  
Jun 1983  
(Courtesy of Franklin Jaquish)

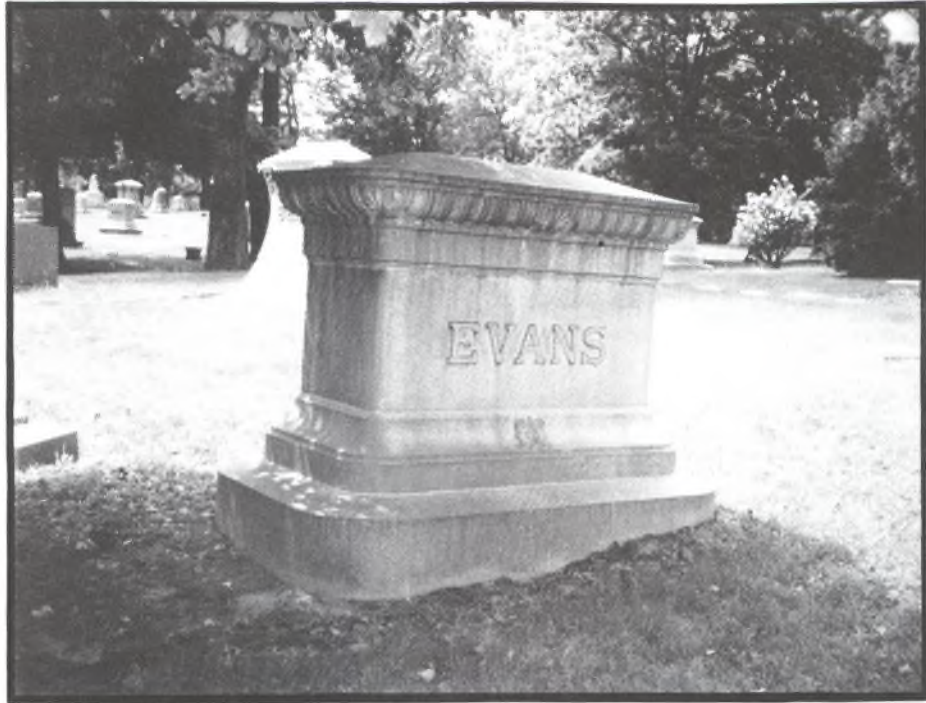

Evans monument.  
Highland Cemetery  
Covington, KY  
Sep 1997  
(Courtesy of Bob Stahr)

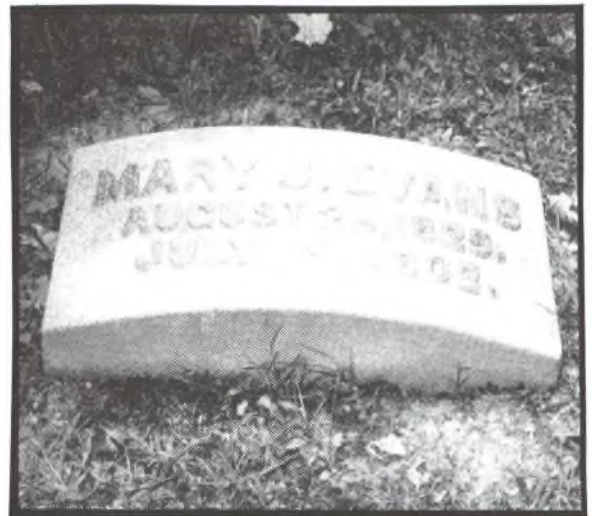
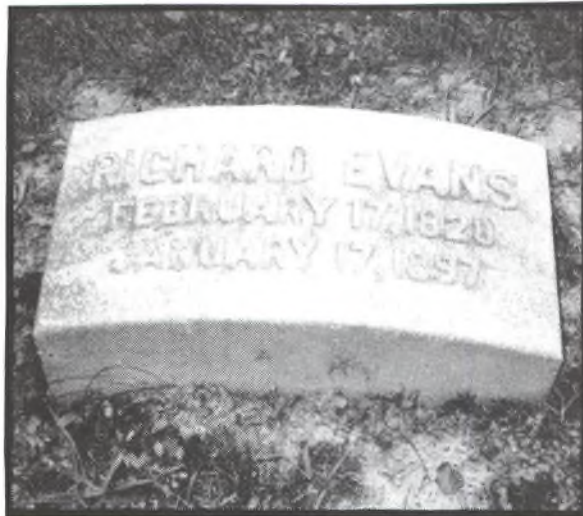

Graves of Richard and Mary J. Hemingray Evans.  
Highland Cemetery  
Covington, KY  
Sep 1997  
(Courtesy of Bob Stahr)



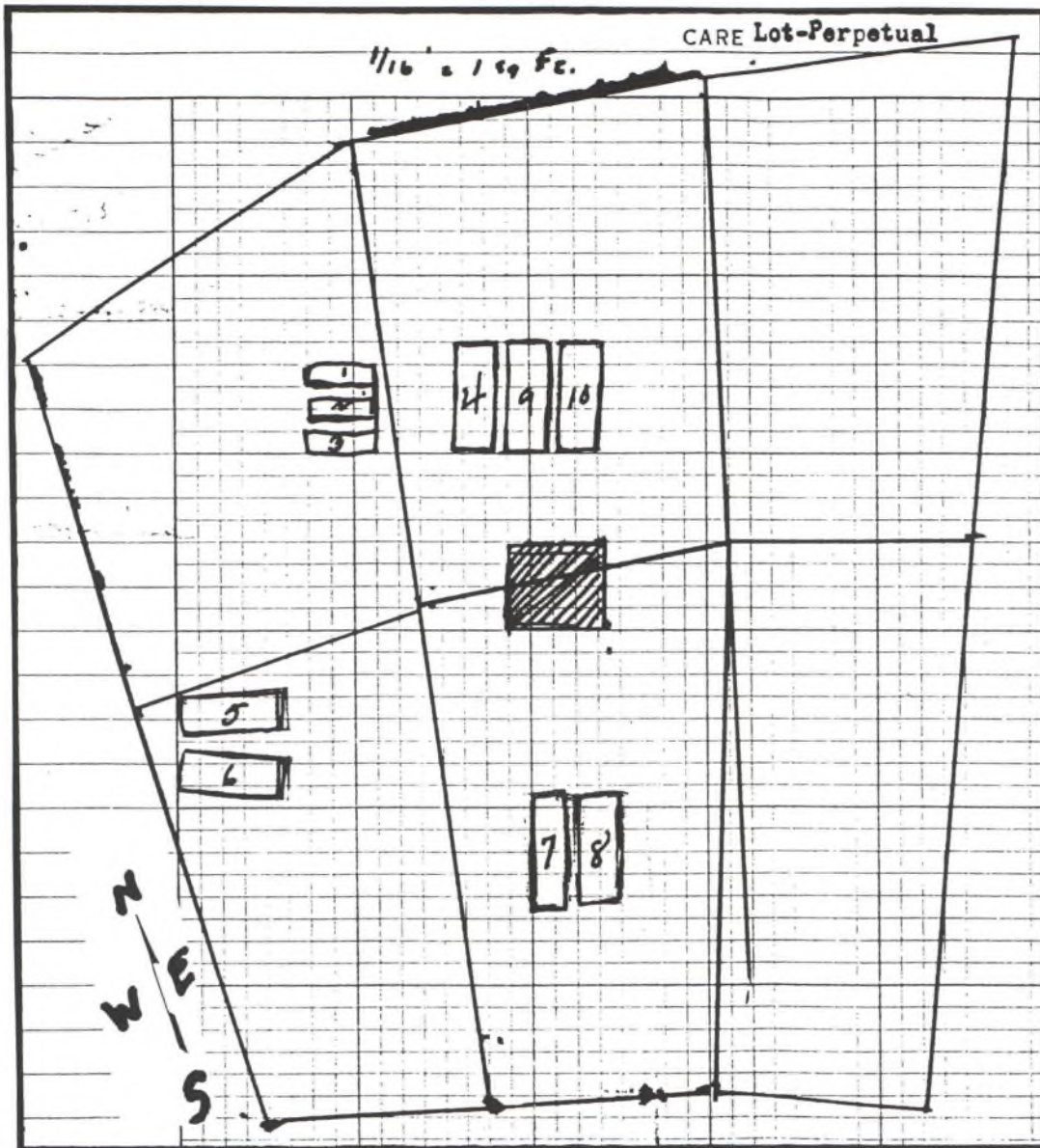

Close-up of Shinkle plot.  
(Courtesy of Rebecca Haake)

- |   |                            |
|---|----------------------------|
| 1-3. Infant children (triplets?)<br>of Bradford Shinkle, buried<br>17 Jul 1875. | 6. Sarah Shinkle           |
| 4. Annie H. Shinkle   | 7. Amos Shinkle            |
| 5. Peter Shinkle  | 8. Sarah Jane Shinkle      |
|   | 9. Bradford Shinkle (I)    |
|   | 10. Mary Hemingray Shinkle |

Section I Lots 1-11 Deed No. 197 5910 Sq. Ft.  
17 Oct. 1873 \$1,182.60



Long view of the Shinkle monument.  
Highland Cemetery, Covington, KY  
Jun 1983  
(Courtesy of Franklin Jaquish)



Close-up of Shinkle monument.  
Highland Cemetery, Covington, KY  
Jun 1983  
(Courtesy of Franklin Jaquish)



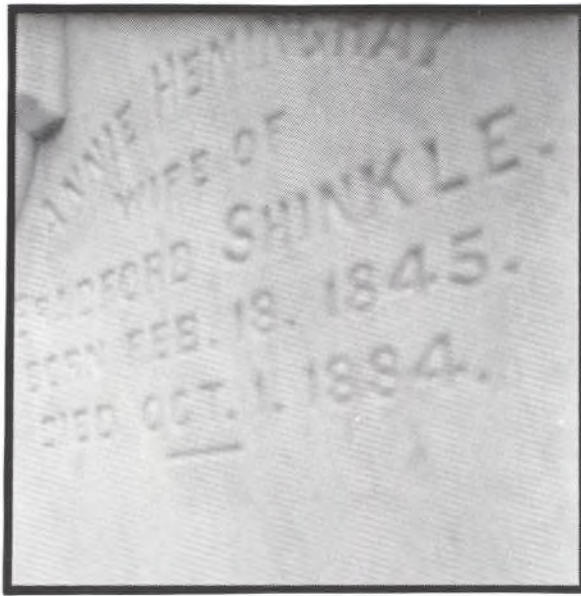

Close-up of engraving on Shinkle monument.  
 Highland Cemetery, Covington, KY  
 Jun 1983  
 (Courtesy of Franklin Jaquish)



Graves of Mintie Carroll Hemingray McAbee,  
 Ralph Hemingray McAbee, and Philip Warrington McAbee.  
 Beech Grove Cemetery  
 Muncie, IN  
 1997  
 (Courtesy of Rosella Cartwright)

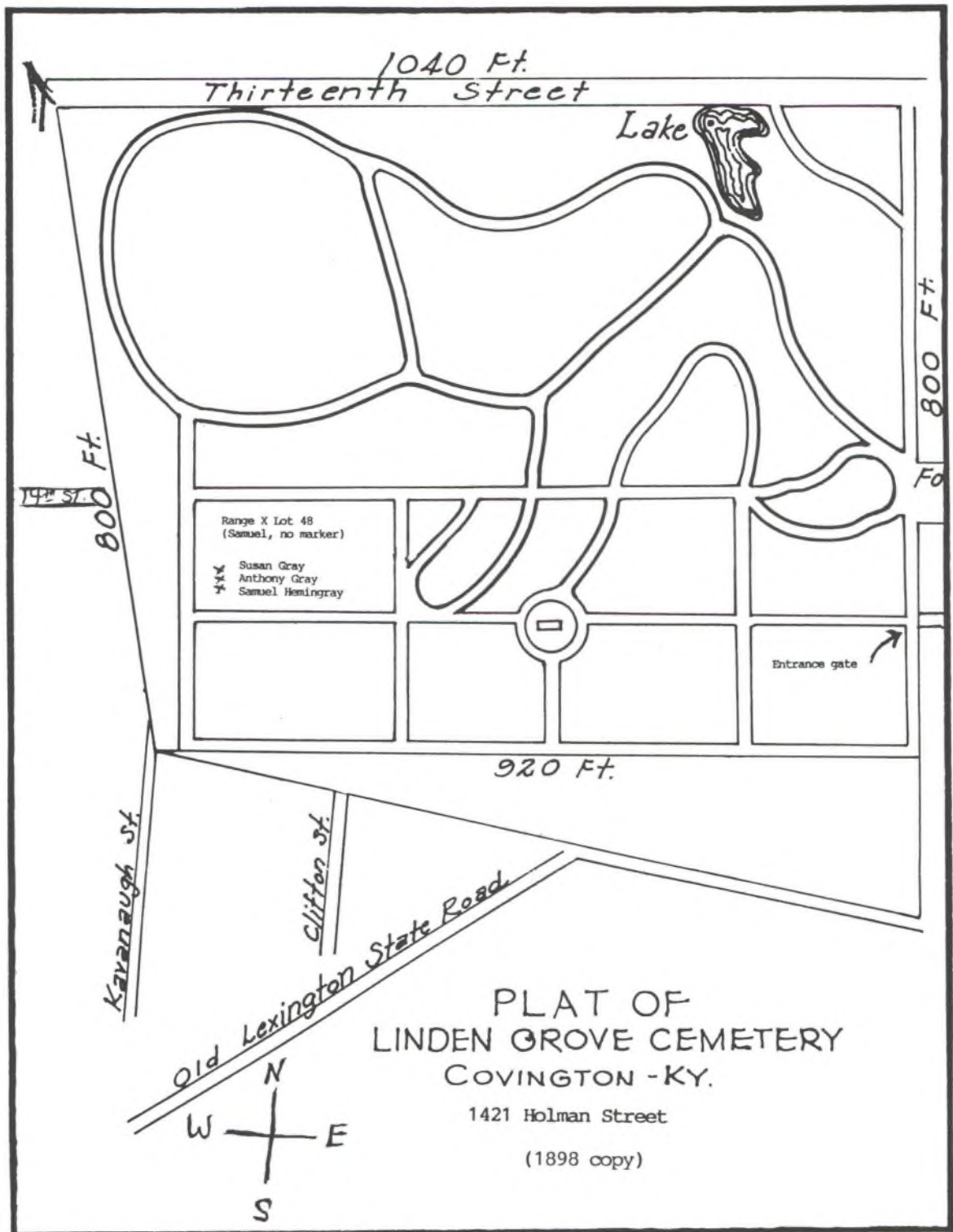

Copy from 1898 canvas map of Linden Grove Cemetery.  
 (Xs show 3 gravesites, arrow shows entrance gate.)  
 Original map is at City Engineering Dept.,  
 Covington, KY  
 (Courtesy of Franklin Jaquish)





Long view of the two graves.  
Linden Grove Cemetery  
Covington, KY  
1997  
(Courtesy of Franklin Jaquish)



Anthony on left, Susan on right.  
Linden Grove Cemetery  
Covington, KY  
1997  
(Courtesy of Franklin Jaquish)



Grave of Anthony Gray.  
Linden Grove Cemetery  
Covington, KY  
1997  
(Courtesy of Franklin Jaquish)



Grave of Susan Carroll Gray.  
Linden Grove Cemetery  
Covington, KY  
1997  
(Courtesy of Franklin Jaquish)





Long view of the Gray monument.  
 Spring Grove Cemetery  
 Cincinnati, OH  
 Jun 1997  
 (Courtesy of Bob Stahr)

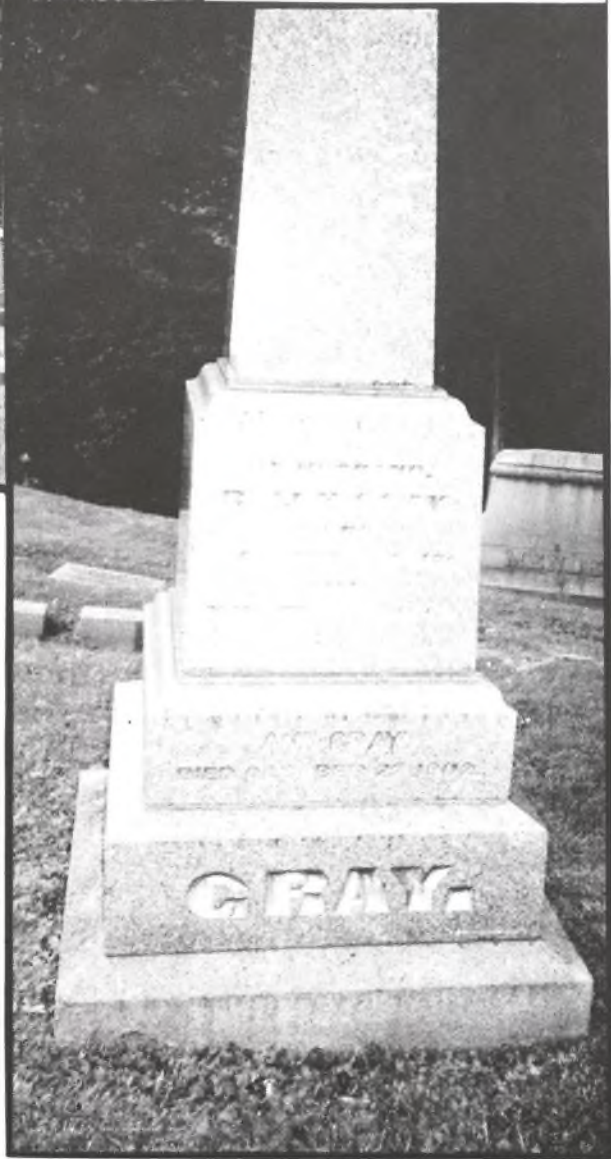

Close-up of the Gray monument.  
 Ralph and Ann Friar Gray.  
 Spring Grove Cemetery  
 Cincinnati, OH  
 Jun 1997  
 (Courtesy of Bob Stahr)

# OBITUARIES

## DIED

In Covington, Monday morning, at 6½ o'clock, after a short illness, RALPH GRAY, of the firm Gray, Hemingray, & Co.

Obit for Ralph Gray.  
THE CINCINNATI DAILY INQUIRER  
1 Dec 1863  
Page 2  
(Courtesy of Glenn Drummond)

\* \* \* \* \*

## COVINGTON

-----

### DEATH OF A WELL KNOWN CITIZEN

We are pained to announce the death of one of our most highly respected citizens, Mr. Samuel J. Hemingray, who expired at his residence on Craig street about 5ve o'clock on Sunday afternoon. Mr. H. had been in feeble health for a year or two, consequently his death was not altogether unexpected. He was a genial, warm-hearted man, beloved by all who knew him, and his death will cast a gloom over the entire community.

Obit for Samuel J. Hemingray.  
THE CINCINNATI DAILY INQUIRER  
11 Sep 1866  
(Courtesy of Glenn Drummond)

\* \* \* \* \*



PIONEER DEAD

-----  
Robert Hemingray, Sr.  
Passed Away.

-----  
HAD BEEN ILL A SHORT TIME  
OF HEART TROUBLE.

-----  
DECEASED WAS A LEADING

-----  
Manufacturer of Glassware in the  
United States.

Robert Hemingray, 79, a pioneer glassware manufacturer of the United States died Tuesday at 8:45 a.m., at his home, 219 Garrard Street, Covington.

Mr. Hemingray had been ill for three weeks with heart trouble, but it was not of a serious nature until a few days ago, when he took a turn for the worse. He was, it is claimed, the oldest glassware manufacturer in the country.

He leaves a widow, three sons -- Ralph, Robert, and Dan. C., and two daughters -- Mrs. Bradford Shinkle, of Covington, and Mrs. W. H. Felix, of Lexington. The funeral will take place from the family residence Thursday noon.

Mr. Hemingray was for many years one of Covington's foremost citizens. Of late years he had retired from active business, leaving his large interests in the manufacture of glassware to his sons.

He was born near Johnstown, Pa., and came to Covington in 1847. One year later he founded the Hemingray Glass Company, which is still in existence.

\* \* \* \* \*

Obit for Robert Hemingray.  
THE KENTUCKY POST  
27 Dec 1898  
(Courtesy of Glenn Drummond)

**ROBERT HEMINGRAY DEAD.**

Well Known Man Passes Away at His Home in Covington, Ky.

Relatives of Robert Hemingray, in this city, were notified by telegram of his death at his home in Covington, Ky., at 9 o'clock this morning.

The deceased has not been in good health for some time, but until day before yesterday, his condition was not considered serious. His death will come as a shock to his many friends in this city, as he was one of the best known men in this city.

Until a few months ago, he was in apparently good health, and would travel alone between this city and Cincinnati, where two of his sons are interested in the glass manufacturing business. Miss Lawellen Hemingray, a grand daughter, left for Cincinnati this morning. A son, E. G. Hemingray, owner of the Hemingray glass works of this city, will go at once to attend the funeral of his father. R. C. Hemingray, another son, resided here until recently.

Obit for Robert Hemingray.  
 THE MUNCIE DAILY HERALD  
 27 Dec 1898

(Courtesy of the Muncie Public Library)

**THE HEMINGRAY DEATH.**

What a Cincinnati Paper Says of the Veteran Glass Man.

In reporting the death of Robert Hemingray, the pioneer glass manufacturer, Tuesday morning, a Covington correspondent of the Cincinnati Commercial Tribune says:

Robert Hemingray, aged 77 years, one of Covington's oldest and most highly esteemed citizens, died yesterday morning at 3:45 o'clock, at his residence, 219 Cartard Avenue, after an illness of three weeks of heart trouble. Mr. Hemingray was born in Johnstown, Pa., in 1829. He came to Covington in 1847, and a year later started a small glass factory at the foot of Madison Avenue, on the bank of the Ohio river. The venture proved successful, and as the business increased the Hemingray Glass works was enlarged, until it became one of the largest in the country. The plant remained in Covington until about ten years ago, when it was removed to Muncie, Ind., owing to the advantages of the site in Indiana. Mr. Hemingray retired from business a few years ago, leaving his interests in the hands of his sons, who have been very successful. The plant is still in Muncie, with the main office in this city. A widow and five grown children survive. Mr. Hemingray was married to Mrs. S. H. Kelly, of Lexington, and Messrs. Robert, Daniel and Ralph Hemingray. He was a member of the Muncie Chamber of Commerce, and was a member of the family of the Hemingray family.

The news of the death shocked the many friends of the well known Hemingray family in this city, and they have the entire sympathy of all. As a result of the death the Hemingray factory has not been at work, and will not resume until after the funeral has been conducted today. Robert and Ralph Hemingray and their families together with John M. Gray and many employees in the factory, some of whom have been employed in the Hemingray factory for more than a score of years, will attend the funeral. Mr. Hemingray was regarded as the oldest living glass manufacturer.

Obit for Robert Hemingray.  
 THE MUNCIE MORNING NEWS  
 29 Dec 1898

(Courtesy of the Muncie Public Library)

(Typed version on next page)



THE HEMINGRAY DEATH

-----

What a Cincinnati Paper Says of  
the Veteran Glass Man.

In reporting the death of Robert Hemingray, the pioneer glass manufacturer [who died?] in Covington, Ky., Tuesday morning. A Covington correspondent of the Cincinnati Commercial Tribune says:

Robert Hemingray, aged 78 years, one of Covington's oldest and most highly esteemed citizens, died yesterday morning at 3:45 o'clock at his residence, 219 Garrard avenue, after an illness of three weeks of heart trouble. Mr. Hemingray was born in Johnstown, Pa, in 1820. He came to Covington in 1847, and a year later started a small glass factory at the foot of Madison avenue on the bank of the Ohio river. The venture proved successful, and as the business increased the Hemingray Glass works was enlarged until it became one of the largest in the country. The plant [remained?] in Covington until about ten years ago, when it was removed to Muncie, Ind., owing to the advantages of the gas belt in Indiana. Mr. Hemingray retired from business a few years ago, leaving his interests in the hands of his sons who have been very successful. The plant is still in Muncie, with the main office in this city. A widow and five grown children survive him. The children are Mrs. Shinkle, Mrs. F. H. Felix of Lexington, and Messrs Robert, Daniel and Ralph Hemingray. The funeral will take place [at the?] family [residence?] Thursday morning.

The news of the death shocked the many friends of the well known Hemingray family in this [area?], and they have the entire sympathy of all. As a result of the death the Hemingray factory has not been at work, and will not resume until after the funeral has been conducted today. Robert and Ralph Hemingray and their families together with John M. Gray and many employes in the factory, some of whom have been employed in the Hemingray factory for more than a score of years, will attend the funeral. Mr. Hemingray was regarded as the oldest living glass manufacturer.

\*\*\*\*\*

Obit for Robert Hemingray.

THE MUNCIE MORNING NEWS

29 Dec 1898

Page 7, col. 4

(Courtesy of Glenn Drummond)

HEMINGRAY FUNERAL.

-----

Pioneer Citizen Laid to Rest in  
Highland Cemetery.

The funeral of the late Robert Hemingray, Sr., took place Thursday noon from the family residence, 219 Garrard Street.

The services were conducted by Rev. C. G. Jones, of the First Baptist Church, and were private. A large number of friends were present.

The pallbearers were Richard Evans, of Pittsburg; Edgar Evans, of Covington; John Gray, of Muncie, Ind.; Clifford Shinkle and Robin Hemingray, of Covington; William Felix, of Lexington; and Dr. Cross of Walnut Hills.

The interment was made at Highland Cemetery. Harbuck & Rose had charge of the funeral.

\* \* \* \* \*

Obit for Robert Hemingray.

THE KENTUCKY POST

29 Dec 1898

(Courtesy of Glenn Drummond)

Robert Hemingray, a pioneer glass manufacturer, died Tuesday, December 27th, at his home in Covington, Ky. Mr. Hemingray had been ill for three weeks with heart trouble, but it was not of a serious nature until just before his death. He was said to be the oldest glassware manufacturer in the country. He leaves a wife, three sons—Ralph, Robert and Daniel C.—and two daughters—Mrs. Bradford Shinkle of Covington and Mrs. W. H. Felix of Lexington. The funeral took place from the family residence Thursday noon, December 29th. Mr. Hemingray was for many years one of Covington's foremost citizens. Of late years he had retired from active business, leaving his large interests in the manufacture of glassware to his sons. He was born near Johnstown, Pa., and settled at Covington in 1847. One year later he founded the Hemingray Glass company, which has since been conducted by himself and his sons.

\* \* \* \* \*

Obit for Robert Hemingray.

WESTERN ELECTRICIAN, Vol. XXIV No. 1

7 Jan 1899

(Courtesy of Glenn Drummond and Bill Meier)



### MRS. HEMINGRAY DEAD.

After Years of Patient Suffering the End  
Came Peacefully.

Mrs. Ralph Hemingray died at the Walker home on West Washington Street, in this city yesterday afternoon after an illness of several years. Tuberculosis was the cause of death. For several years Mrs. Hemingray was a patient sufferer. The best medical attention in the country was given her but her relief was obtained only at intervals. Yesterday morning she gave up all hope of ever recovering and summoned the family. Death occurred about 3:30 in the afternoon.

Until failing health made activity impossible Mrs. Hemingray was active in Muncie society. Before her marriage to Mr. Hemingray she was Miss Jane Matthews, of Covington. Her family was one of the best known in that part of the state. Ex-Governor Claude Matthews, of Indiana, was a brother. Mr. Hemingray is owner of the Hemingray glass factory.

A husband and two daughters survive. The remains will be taken to Covington for interment.

Few women are possessed of more amiable temperaments than that of Mrs. Hemingray. Through all the years of martyrdom to pain, she bore up bravely and cheerfully. Her passing from life and from the friends whom she treasured so dearly, was unusually pathetic.

Obit for Jane Matthews (Mrs. Ralph) Hemingray.  
THE (MUNCIE) TIMES  
3 Sep 1900  
(Courtesy of Rosella Cartwright and  
the Muncie Public Library)

(Typed version on next page)

(Typed version on next page)

### ROBERT HEMINGRAY.

Well Known Manufacturer  
Passes Away.

Robert Hemingray, well and favorably known in Muncie, died at Covington, Ky., yesterday. His death was sudden but not unexpected as for many months there had been no hope of recovery. Paralysis of the brain is given as the direct cause of death.

Until failing health forced his retirement, Mr. Hemingray was an active member of the Hemingray Glass company. He was associated with his father, founder of the company, and his brothers, Ralph and Dan. He was popular with the workmen and with business men generally. Few men in Muncie have been better liked and possessed of more friends.

Mr. Hemingray is survived by a wife and three children, who make their home in Muncie. The sons, Conway and Robin, were notified of their father's death while in St. Louis. Mr. Ralph Hemingray left for Covington last evening to make arrangements for the burial. Mrs. Hemingray and daughter, Miss Ashley, left today. The deceased was a charter member of the local lodge of Elks and that organization will doubtless be represented at the burial which will be held Sunday.

Obit for Robert C. Hemingray.  
THE MUNCIE DAILY NEWS  
27 Jul 1901

Page 1, col. 5  
(Courtesy of the Muncie Public Library)

MRS. HEMINGRAY DEAD.

-----  
After Years of Patient Suffering the End  
Came Peacefully  
-----

Mrs. Ralph Hemingray died at the Walker home on West Washington street, in this city yesterday afternoon after an illness of several years. Tuberculosis was the cause of death. For several years Mrs. Hemingray was a patient sufferer. The best medical attention in the country was given her but her relief was obtained only at intervals. Yesterday morning she gave up all hope of ever recovering and summoned the family. Death occurred about 3:30 in the afternoon.

Until failing health made activity impossible Mrs. Hemingray was active in Muncie society. Before her marriage to Mr. Hemingray she was Miss Jane Matthews, of Covington. Her family was one of the best known in that part of the state. Ex-Governor Claude Matthews, of Indiana, was a brother. Mr. Hemingray is owner of the Hemingray glass factory.

A husband and two daughters survive. The remains will be taken to Covington for interment.

Few women are possessed of more amiable temperaments than that of Mrs. Hemingray. Through all the years of martyrdom to pain, she bore up bravely and cheerfully. Her passing from life and from the friends whom she treasured so dearly, was unusually pathetic.

\* \* \* \* \*

(Courtesy of Glenn Drummond)

ROBERT HEMINGRAY

-----  
Well Known Manufacturer  
Passes Away  
-----oOo-----

Robert Hemingray, well and favorably known in Muncie, died at Covington, Ky., yesterday. His death was sudden but not unexpected as for many months there had been no hope of recovery. Paralysis of the brain is given as the direct cause of death.

Until failing health forced his retirement, Mr. Hemingray was an active member of the Hemingray Glass company. He was associated with his father, founder of the company, and his brothers, Ralph and Dan. He was popular with the workmen and with business men generally. Few men in Muncie have been better liked and possessed of more friends.



Mr. Hemingray is survived by a wife and three children, who make their home in Muncie. The sons, Conway and Robin, were notified of their father's death while in St. Louis. Mr. Ralph Hemingray left for Covington last evening to make arrangements for the burial. Mrs. Hemingray and daughter, Miss Ashley, left today. The deceased was a charter member of the local lodge of Elks and that organization will doubtless be represented at the burial which will be held Sunday.

\* \* \* \* \*

(Courtesy of Glenn Drummond)

ROBT. HEMINGRAY DEAD.

-----

Robert Hemingray of Covington, Ky., died suddenly yesterday at the Sanatorium at Collage Hill, Ohio, says the Cincinnati Enquirer, where he had been for several years suffering with nervous prostration due to over work that baffled the medical experts all over the country.

He leaves a widow, formerly Miss Nannie Timberlake, one daughter and two sons. The father went to the front in the Spanish American war. He was a son of the late Robert Hemingray, the founder and owner of the Hemingray glass works formally of Covington, now located at Muncie, Ind.

His brother, Ralph G. Hemingray, is now the president of the glass works at Muncie, and another brother, Dan Hemingray, is also associated with the same concern. His sister, Mrs. Bradford Shinkle, is the wife of the president of the Covington and Cincinnati Suspension Bridge Co. A sad feature in connection with his sudden death is the absence of the members of his family.

Mrs. Robert Hemingray, widow of the deceased, and daughter, Miss Sue who have made their home in this city during the husband and father's illness in Covington, left this morning accompanied by other relatives of the Hemingray family who will attend the funeral in that place Sunday. Conway Hemingray of St. Louis and Robert Hemingray, at present in the East, sons of the deceased, will also attend the funeral.

\* \* \* \* \*

Obit for Robert C. Hemingray.

THE MUNCIE DAILY HERALD

27 Jul 1901

Page 1, col. 6

(Courtesy of Glenn Drummond)

MRS. ROBERT HEMINGRAY IS DEAD

-----

Mrs. Mary Hemingray, widow of the late Robert Hemingray, passed away at 1:30 o'clock Monday morning at her residence, 219 Garrard Street, Covington after a lingering illness. Mrs. Hemingray was in her eighty-first year and had been a resident of Covington for 50 years. Her husband was for many years prominent in Covington business circles, as president of the Hemingray Glassworks. Five children survive her. They are: Mrs. William Felix, of Lexington; Mrs. Bradford Shinkle, of Covington; and three sons -- Ralph, Robert, Jr., and Daniel Hemingray. The funeral will take place from the residence at 1:30 Wednesday afternoon. The services will be conducted by the son-in-law, Rev. Mr. Felix, of Lexington. Interment in Highland Cemetery. Members of the family will act as pallbearers.

\* \* \* \* \*

Obit for Mary Carroll Hemingray.

THE KENTUCKY POST

27 May 1901

Page 5

(Courtesy of Glenn Drummond)

ROBT. HEMINGRAY PASSES AWAY

Robert C. Hemingray, 46, of Covington, died Friday afternoon at 4:30 o'clock at a private hospital, College Hill, Cincinnati. Mr. Hemingray has been ill for several months with heart trouble, and it is thought that the extreme heat of the last few days hastened the end. He was a son of Robert Hemingray, a pioneer Covingtonian, who founded the Hemingray glassworks, of this city, and Muncie, Ind. Two brothers and two sisters survive him. They are Dan and Ralph Hemingray, Mrs. Bradford Shinkle, of Covington, and Mrs. William H. Felix, of Lexington, Ky. He also leaves a wife and three children, Robert, Jr., Conway and Miss Ashley Hemingray. They live in Lexington. The remains will be interred in the family lot in Highland Cemetery. Further funeral arrangements have not been made.

\* \* \* \* \*

Obit for Robert C. Hemingray.

THE KENTUCKY POST

27 Jul 1901

Page 1

(Courtesy of Glenn Drummond)



DEATH OF J. C. GILL

-----  
PASSED AWAY AT HIS HOME  
FRIDAY EVENING

-----O-----  
HE WAS A GLASS WORKER  
-----O-----

James C. Gill, [50], died at his home 414 North Jefferson street at 8 o'clock Friday evening. Mr. Gill has been confined at his home for three weeks from dropsy and heart trouble. He was born in Wheeling, West Virginia in 1832. For the last 25 years he has been foreman at Hemingray's mould shops. Mr. Gill has a daughter May and son James. His daughter has been residing at Cincinnati and was sent for when Mr. Gill's condition became worse. His daughter had barely arrived when he died. Mrs. Gill and James were also beside him when he died.

Mr. Gill was well known in labor circles having been active in labor interests for a good many years.

The funeral announcements will be made in Sunday's paper.

\* \* \* \* \*

Obit for James C. Gill.  
THE (MUNCIE) MORNING STAR  
18 Jan 1902  
Page 12, col. 2  
(Courtesy of Glenn Drummond)

DEATHS

GILL -- Funeral services over the remains of James Gill will be held, this afternoon, at 3 o'clock at the residence, 414 North Jefferson street. The Rev. W. H. Oxtoby will be in charge. At 7 o'clock, Monday morning, the body will be taken to Cincinnati, where interment will be made in Spring Grove cemetery.

\* \* \* \* \*

Obit for James C. Gill.  
THE (MUNCIE) MORNING STAR  
19 Jan 1902  
Page 2, col. 3  
(Courtesy of Glenn Drummond)

WILL WAS PROBATED

The will of the late Ann Gray, widow of Ralph Gray, was recorded in the Kenton County Clerk's office Friday. Out of her individual and separate estate and property the executors are to pay to her niece, Mrs. Virginia Emma Owens, of St. Louis, Mo. \$1300. To her nieces May S. Ingram and Jane Kirk, she leaves certain property, they to share it alike during their lives. After their death it goes in fee to the heirs. If either of them should die without leaving children surviving them then the shares of such deceased to go to the heirs of Virginia Owens. All the rest of the estate is to go to the children by adoption of Kalista Gray and Robert Kerns Gray, niece and nephew of Ralph Gray.

\* \* \* \* \*

Article about will of Ann Gray.  
THE KENTUCKY POST  
17 Jan 1903  
(Courtesy of Glenn Drummond)

WE MANUFACTURE

**Standard**

**Screw Glass Insulators**

FOR ALL PURPOSES

---

**Hemingray Glass Co.**

ESTABLISHED 1848

**Office: Covington, Ky.**

FACTORIES: MUNCIE, IND.

Company ad.  
The Electrical World and Engineer  
20 Jun 1903  
(Courtesy of Elton Gish)



# HEMINGRAY LOSES FIGHT WITH DEATH

Prominent Glass Manufacturer, Succumbs at Queen City Club.

Daniel Carroll Hemingray, 53, of Wendale, died after a short illness at the Queen City Club at 5 o'clock Thursday morning.

Mr. Hemingray, who was secretary and treasurer of the Hemingray Glass Co., of Covington, Ky., and Muncie, Ind., and a prominent clubman, was taken ill Tuesday night. Apoplexy caused death.

Thursday evening Mr. Hemingray with a party of friends was returning home from his office at Covington. On reaching Cincinnati he complained of feeling ill and was taken to the Queen City Club. He was removed to a room and Drs. Ed Walker, Harry H. Hill, Frank Cross and two nurses were called.

Wednesday his condition was believed to be improved, but during the night he suffered a relapse, which proved fatal. He was conscious up to five minutes before his death.

Classmate of Taft  
Besides his interests in the glass company, he was a member of the Board of Directors of the Cincinnati Trust Company.

Mr. Hemingray was born in Covington, a son of Robert Hemingray. At Woodward High School he was a classmate of President Taft. After graduation there he went to Chickering preparatory school and later to the Massachusetts Institute of Technology. He returned to Cincinnati before his graduation there and entered business with his father and brother, Ralph J. Hemingray.

Mr. Hemingray was known as a charitable man and made many contributions for public welfare. His constantly cheerful disposition made him one of the most beloved men in Cincinnati.

Held Public Office  
At one time he was a member of the Covington Water Works Board.

Until a year ago, Mr. Hemingray and his wife lived in Covington.

Ralph J. Hemingray, the brother who is President of the Hemingray Co., with offices in Muncie, arrived in Cincinnati Wednesday afternoon.

Mr. Hemingray is survived by the widow, his brother and two sisters, Mrs. Bradford Shinkle and Mrs. W. H. Feltz, of Chilesburg, Kentucky.

Rev. William H. Feltz, now visiting in Clearwater, Fla.,



(Photo by Bellamy.)  
DANIEL HEMINGRAY.

brother-in-law, will have charge of the funeral services when he arrives in time. The services will be held Saturday at Highland Cemetery Chapel, Covington, with interment in that cemetery.

During his short illness Mr. Hemingray was called on by scores of friends. A number of his personal acquaintances waited near his room until the early hours of Wednesday and Thursday.

Obit for Daniel C. Hemingray.  
THE KENTUCKY POST  
14 Dec 1911  
(Courtesy of the Kenton Co. Public Library)

(Typed version on next page)

HEMINGRAY  
LOSES FIGHT  
WITH DEATH

-----  
Prominent Glass Manu-  
facturer Succumbs at  
Queen City Club.  
-----

Daniel Carroll Hemingray, 54, of Glendale, died after a short illness at the Queen City Club at 5 o'clock Thursday morning.

Mr. Hemingray, who was Secretary and Treasurer of the Hemingray Glass Co., of Covington, Ky., and Muncie, Ind., and a prominent clubman, was taken ill Tuesday night. Apoplexy caused death.

Tuesday evening Mr. Hemingray with a party of friends was motoring home from his offices in Covington. On reaching Cincinnati he complained of feeling ill and was taken to the Queen City Club. He was removed to a room and Drs. Ed Walker, Harry H. Hines, Frank Cross and two nurses were called.

Wednesday his condition was believed to be improved, but during the night he suffered a relapse which proved fatal. He was conscious up to five minutes before his death.

Classmate of Taft

Besides his interests in the glass company, he was a member of the Board of Directors of the Cincinnati Trust Company.

Mr. Hemingray was born in Covington, a son of Robert Hemingray. At Woodward High School he was a classmate of President Taft. After graduating there he went to Chickering preparatory school and later to the Massachusetts Institute of Technology. He returned to Cincinnati before his graduation there and entered business with his father and brother, Ralph G. Hemingray.

Mr. Hemingray was known as a charitable man, and made many subscriptions for public welfare. His constantly cheerful disposition made him one of the most beloved men in Cincinnati.

Held Public Office

At one time he was a member of the Covington Water Works Board.

Until a year ago, Mr. Hemingray and his wife lived in Covington.

Ralph G. Hemingray, the brother who is President of the Hemingray Co., with offices in Muncie, arrived in Cincinnati Wednesday afternoon.

Mr. Hemingray is survived by the widow, his brother and two sisters, Mrs. Bradford Shinkle and Mrs. W. H. Felix of Childsburg, Kentucky.

Rev. William H. Felix, now visiting in Clearwater, Fla., a brother-in-law will have charge of the funeral services if he arrives in time. The services will be held Saturday at Highland Cemetery Chapel, Covington, with interment in that cemetery.



During his short illness Mr. Hemingray was called on by scores of friends. A number of his personal acquaintances waited near his room until the early hours of Wednesday and Thursday.

\* \* \* \* \*

Obit for Daniel C. Hemingray.  
THE KENTUCKY POST  
14 Dec 1911  
Page 1, col. 6  
(Courtesy of Glenn Drummond)

*Established 1848*

# **HEMINGRAY GLASS CO.**

*Incorporated 1870*

**Factories, Muncie, Ind.      Office, Covington, Ky.**

*Manufacturers of the Celebrated*

## **Muncie and Provo Type High Tension**

# **INSULATORS**

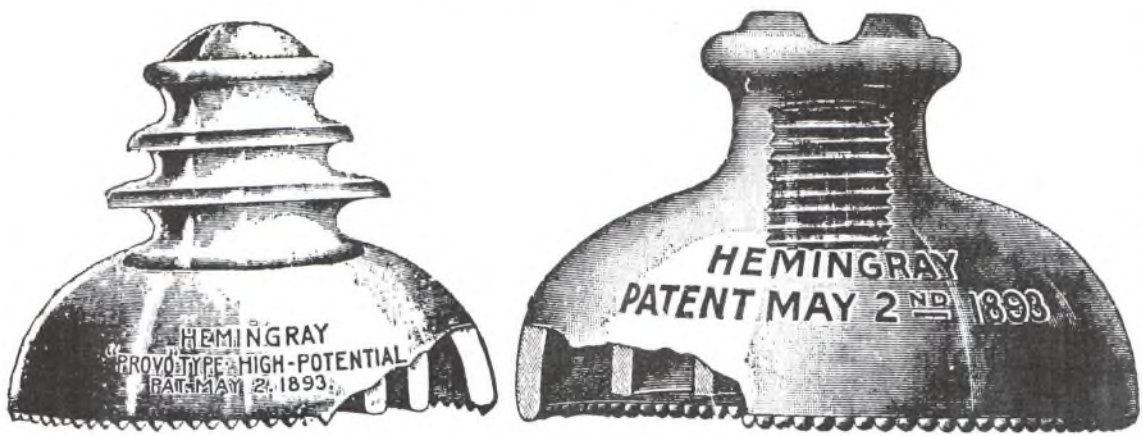

The image shows two glass insulators. The one on the left is a Provo Type High-Potential insulator, featuring a tiered top and a bulbous base with a small opening. The one on the right is a Muncie Type insulator, also with a tiered top and a bulbous base, but with a larger opening and a distinct vertical ribbed section. Both have embossed text on their bases.

Company ad.  
Journal of the American Institute of Electrical Engineers  
Nov 1907  
(Courtesy of Elton Gish)

DAN HEMINGRAY DIES

-----  
One of Early Investors in Indiana Gas Belt.  
-----

Apoplexy is the Cause  
-----

Daniel Carroll Hemingray, 54, one of the founders and secretary and treasurer of the Hemingray Glass company of Muncie and a man who has had much to do in an industrial way with the development of the city many years ago, died early yesterday morning in Cincinnati, Ohio. His brother, Ralph Hemingray, was connected with him in the glass manufacturing business in Muncie and Covington, Ky. Daniel C. Hemingray had spent much time in Muncie and many residents of the city will be shocked to hear of his death. Although not a resident of Muncie, Mr. Hemingray had much to do with the glass industry here.

Death resulted from a stroke of paralysis, Mr. Hemingray having been stricken at the Queen City club in Cincinnati Tuesday evening. He resided in Glendale, a suburb, and was on his way home when he felt ill and stopped at the club. Physicians deemed it unwise to have him removed to his home and death soon came. He was the son of Robert Hemingray, who founded the Hemingray Glass company, and who also was well known in this city.

The deceased is survived by a widow, one brother and two sisters, Mrs. Bradford Shinkle and Mrs. W. H. Felix of Childsburg, Ky. The Rev. W. H. Felix, a brother-in-law, who is now in Florida, will conduct the funeral service from the chapel of the Highland cemetery Saturday afternoon.

Mr. and Mrs. Ralph Hemingray are in Cincinnati. The funeral arrangements have not been completed. It is likely that other Muncie people will go to Covington to attend the funeral. Mr. Hemingray was a graduate of Yale University.

\* \* \* \* \*

Obit for Daniel C. Hemingray.

THE (MUNCIE) MORNING STAR

15 Dec 1911

Page 1, col. 3

(Courtesy of Glenn Drummond and Rosella Cartwright)



## PARALYSIS

-----  
Dealt a Swift Blow

-----  
And Gave Death a Princely Man  
For a Victim

-----  
"Dan" Hemingray, Manufac-  
turer and Clubman

-----  
Stricken in an Automobile on the  
Way From His Office To His Home.

-----  
After having been stricken with paralysis when apparently in the full flush of health, Daniel Carroll Hemingray, glass manufacturer and clubman, passed away shortly after 5 o'clock yesterday morning in a private room at the Queen City Club. He regained consciousness a short time before death and recognized and spoke to the members of his family who gathered about his bedside.

Mr. Hemingray was stricken on Tuesday afternoon while in his automobile on the way from the Hemingray Glass Company in Covington to his home in Glendale. Shortly after the machine reached this side of the river Mr. Hemingray complained to a friend who accompanied him that he was feeling ill and distressed, and the chauffeur was instructed to drive quickly to the Queen City Club, of which he was a member. He was helped from the auto and taken to one of the sleeping rooms where Dr. Harry H. Hines was summoned. Examination revealed that the stroke of paralysis was extensive and that it would be extremely dangerous to remove Mr. Hemingray to either his home or a hospital.

Dr. Ed Walker and other physicians were called into consultation, and nurses were secured and the fight for life began.

On Wednesday the patient at times exhibited symptoms of dangerous sinking spells and on several occasions reports were current that the end was near. His friends at the club did all they could to assist the physicians and nurses. Wednesday evening he again developed sinking spells and the physicians gave up hope.

### Had a Host of Friends

"Dan" Hemingray, as he was universally known, was probably one of the best known men in the city. His jovial disposition and good fellowship was a magnet that drew about him for intimates a cluster of friends to whom his death will be a sad blow. He was always smiling and his appearance at the Queen City Club was always hailed with delight. There were no dull moments in his company and many are the Queen City members who, depressed with the cares of business, found mental rest from their worries in the optimistic, jovial and happy temperament of "Dan" Hemingray.

Mr. Hemingray had many warm personal friends in Covington, where he was highly thought of by scores of persons who were employed at the Hemingray Glass Company before its removal to Muncie, Ind. He was always a man who had comforting words and was ever willing to do a kind turn for his fellow man and for charitable institutions.

He was one of the first stockholders of the Latonia Racing Association, a Director of the Suspension Bridge Company, the Cincinnati Trust Company, and at one time was a member of the Covington Waterworks Department.

The funeral services will take place at the chapel of the Highland Cemetery on the Lexington pike, three miles from Covington, tomorrow afternoon at 3 o'clock.

#### His Family Connections

Mr. Hemingray married Clara Keck, daughter of the late "Si" Keck, and she survives him. His brother, Ralph G. Hemingray, is president of the glass company and makes his home in Muncie, Ind., where the factory is located. Mrs. Bradford Shinkle, of Covington and Mrs. W. H. Felix of Lexington, wife of Rev. W. H. Felix, are surviving sisters. Rev. Mr. Felix now is in Florida.

Mr. Hemingray was born in Covington in 1857, a son of Robert Hemingray. At Woodward High School he was a classmate of President Taft. After graduating there, he went to Chickering Preparatory School and later to the Massachusetts Institute of Technology. He returned to Cincinnati before his graduation there and entered business with his father and brother, Ralph G. Hemingray.

\* \* \* \* \*

Obit for Daniel C. Hemingray.  
THE KENTUCKY POST  
15 Dec 1911  
(Courtesy of Glenn Drummond)



TRIBUTE OF FRIEND

-----o-----

To Memory of Dan C. Hem-  
ingray is Rendered

-----

WAS ALWAYS CHARITABLE

-----o-----

George O'Neil, James Risher and Frank Miller have returned from Cincinnati where they attended the funeral of Dan C. Hemingray, the glass manufacturer who was so well known here because of his ownership, with his brother Ralph, of the Hemingray glass factory. Mr. Hemingray was a member of Muncie lodge of Elks, which gave a beautiful floral tribute and also sent representatives to the funeral. The funeral was one of the most largely attended of any held in that city, many coming from various cities and states to attend it, several being from Muncie. A friend of Mr. Hemingray in a communication to the Star says: "Mr. Hemingray, by his genial disposition and great charity had endeared himself to people in all walks of life, and his funeral was attended by many distinguished people from several states, and mingled with them were also men and women of humble positions, who could truthfully say of this man, "He was my friend." One who had known the Hemingray family for years said: "Wherever the Hemingray brothers and sisters went, there was always sunshine, for they were possessed of such happy dispositions, and were always optimistic, and extremely charitable toward others, and there was always a crowd gathered around to enjoy the sunny atmosphere of their presence.

Twenty-four years ago Dan Hemingray with his brothers established their factory in this city, and, as he was the member of the company who attended to their outside interests, he was largely the means of advertising Muncie's advantages through numerous states, and indirectly induced others to locate here, thus being instrumental in adding several manufacturing industries to the little city which was then beginning to expand. He retained his interest in the Hemingray glass company, which is one of Muncie's substantial industries, until his death. Mr. Hemingray was extremely charitable to those less fortunate than himself, and numerous acts of kindness and many gifts were bestowed upon those in need, of which the world at large knew nothing. He seemingly was satisfied in knowing he had done what he could in an unobtrusive way. He was loved best by those who knew him best, and his going will leave a void in the hearts of his numerous friends.

"What the world needs greatly is men who can smile under difficulties; be optimistic under lowering clouds; and say the kindly word always to their fellowman. Such a man was Daniel Hemingray. For the kind words that he scattered; for the charities he extended; for the geniality he diffused which permeated the hearts of others, may our Divine Father abundantly reward him!"

His life was gentle, and the elements so mixed in him, that nature might stand up and say to all the world: "This was a man!"

\*\*\*\*\*

Obit for Daniel C. Hemingray.

THE (MUNCIE) MORNING STAR

18 Dec 1911

Page 11, col. 6

(Courtesy of Glenn Drummond and Rosella Cartwright)

## An Assurance of Uninterrupted Service



No. 72—10000 Volta

is best secured by a careful selection of the transmission line insulators. It is here that breakdowns are most likely to occur.

### Hemingray Insulators

by reason of their continued use on important transmission lines have demonstrated the soundness of Hemingray design. The teats on the petticoat attract water on the outer and inner surfaces into drops—preventing the creeping of moisture on insulators and pins. The line is complete and the catalog shows it. Have you a copy?

### Hemingray Glass Company

Established 1848 } Covington, Ky.  
Incorporated 1870 }  
Factories: MUNCIE, INDIANA



No. 20—5000 Volta

Company ad.  
Electric Railway Journal  
4 Mar 1916  
(Courtesy of Elton Gish)



CINCINNATI CHAMBER OF COMMERCE.

DANIEL CARROLL HEMINGRAY

Born in the City of Covington, Ky., February 4, 1857.

Died December 14, 1911.

Actively identified with this Chamber of Commerce from the date of his election March 8, 1882, until called from his family, friends and earthly labors, by the fatal visitation that has taken him from our midst.

Ever ready to lend assistance in promoting the welfare and extending the influence of this Association and contributing not a little toward the manufacturing reputation established by this city, whose commercial reputation is vested in this Association.

It is fitting therefore, that expression should be made and a record inscribed in the minutes of this Corporation, of the loss sustained by this body in his untimely separation.

To this end, your Committee [sic] would beg to submit; That in the death of Daniel Carroll Hemingray, the Chamber of Commerce has lost a devoted and beloved member, than whom few were better known or held in more affection. His genial nature and social qualities endeared him to a large circle of friends extending to almost every State in this nation.

As a husband, he was tender and affectionate; as a friend faithful and devoted; as a citizen he was generous and public spirited; and the influence of his example was upon the side of good order and morality.

In his commercial intercourse, he was the soul of honor, and faithful and strict in the discharge of his business obligations, and his premature death is widely mourned, as it ought to be. Therefore be it

RESOLVED, That in the death of Daniel Carroll Hemingray,--This testimonial be inscribed upon the records of the Association--

That it lost a devoted and valued member; his family a loving husband and brother; his friends a man whose like they will ne'er see again; and the community a useful and valued citizen.

F. A. Rothier,  
Levi C. Goodale,  
E. S. Grant,  
John H. Allen,  
Eugene L. Lewis,  
Jamer R. Minor.

Committee.

\* \* \* \* \*

Sixty-third annual report of the Cincinnati Chamber of Commerce and Merchants' Exchange, for the year ending December 31, 1911.

R. T. Morris Printing Co.,

1912

(Courtesy of Glenn Drummond and  
the Cincinnati Historical Society)

HEMINGRAY. June 12, Mrs. N. F. Hemingray.  
Remains at parlors of W. A. Brown.

\* \* \* \* \*

Brief death notice for Nannie T. Hemingray.  
THE LOS ANGELES TIMES  
13 Jun 1915  
(Courtesy of the Los Angeles Public Library)

**FORMER MUNCIE WOMAN  
DIES IN CALIFORNIA**

Ralph Hemingray, a prominent Muncie resident, received word Tuesday of the death of his sister-in-law, Mrs. Robert Hemingray, at her home in Los Angeles, Cal. The deceased was the widow of Robert Hemingray, who, for years, was associated with the Hemingray glass factory here. She was well known throughout Muncie. She moved from Muncie eight years ago and for the past three years has resided in California. She is survived by two sons, Robert and Conway Hemingray, and one daughter, Mrs. Shuning Star. The funeral services will be conducted at Covington, Ky., Friday afternoon.

\* \* \* \* \*

Obit for Nannie T. (Mrs. Robert, Jr.) Hemingray.  
THE MUNCIE EVENING PRESS  
15 Jun 1915  
(Courtesy of the Muncie Public Library and  
Rosella Cartwright)



# R. G. HEMINGRAY DIES SUDDENLY AT COVINGTON, KY.

Prominent Glass Manufacturer  
Passes Away While Visiting  
at Home of Sister.

FUNERAL AT COVINGTON  
ON THURSDAY AFTERNOON

Ralph G. Hemingray, 824 East Washington street, prominent manufacturer and one of the city's best known men, died at 5:10 o'clock Tuesday afternoon, at the home of his sister, Mrs. Wadford Shinkle, near Covington, Ky., after a three days' illness.

Although Mr. Hemingray had not been in good health for more than two years, he had greatly improved and was feeling as well as usual when he left here Saturday with Mrs. Hemingray for a visit with his sister. However, before arriving at his destination he became ill with pleurisy. Sunday and Monday his condition was so improved that he was thought to have almost recovered from the attack, but early Tuesday morning he suffered a relapse. It was at once apparent that his illness was critical and by noon there was little hope for his recovery.

Came to Muncie in 1888.

The first gas boom in Muncie was an additional incentive for industries to move to the natural gas belt, and in January, 1888, Mr. Hemingray, with his father, Robert Hemingray, and brother, Dan Hemingray, announced their decision to move part of their glass factories here from Covington, Ky. The location chosen by this firm, which has continued as one of the big industries of Muncie, was on Macedonia avenue, where it is now. The elder Mr. Hemingray remained here with the new factory until his death, and since that time Mr. Hemingray had been president and general manager.

During his thirty years of residence in this city, Mr. Hemingray was one of the city's most representative citizens. His great generosity was one of his outstanding characteristics and it would be safe to say his friends were legion. He was a life member of the Muncie Lodge of Elks, was a member of the Rotary Club

Continued on Thirteenth Page.

## Prominent Muncie Man Dies in Covington, Ky.

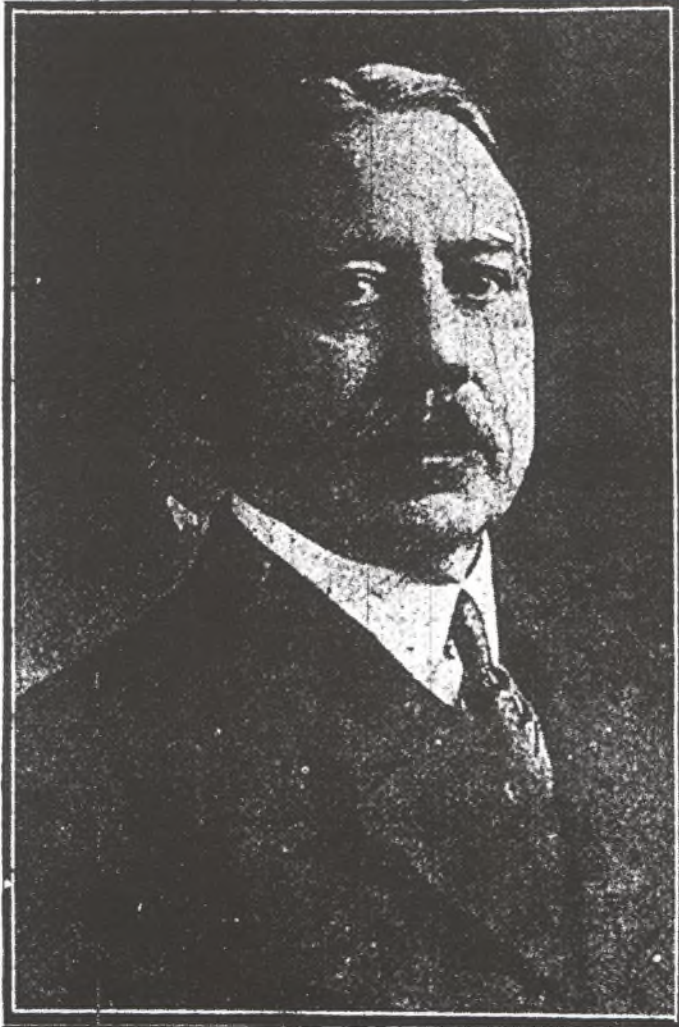

RALPH G. HEMINGRAY.

### R. G. HEMINGRAY DIES

Continued From First Page.

and other of the city's leading organizations.

One Daughter in California.

Mr. Hemingray is survived by the widow, Eva; two daughters, Miss Llewellyn Hemingray, of Covington, and Mrs. Phillip W. McAbee, of Muncie, who left with her husband last Thursday for California. Upon arriving in California yesterday they were notified of Mr. Hemingray's death and started east last evening. Two sisters, Mrs. Shinkle and Mrs. Melle Felix, of Lexington, Ky., also survive. Funeral services will be conducted from the Shinkle home at 4 o'clock Thursday afternoon and interment will be made in the Highland Cemetery at Covington.

A number of Muncie people will go to Covington Thursday to attend the funeral.

Obit for Ralph Hemingray.

THE (MUNCIE) MORNING STAR

12 May 1920

(Courtesy of Rosella Cartwright,  
the Muncie Public Library, Bob Stahr, and  
Ball State Univ., A. M. Bracken Library,  
Archives & Special Collections)

(Typed version  
on next page)



R. G. HEMINGRAY  
DIES SUDDENLY  
AT COVINGTON, KY.

-----  
Prominent Glass Manufacturer  
Passes Away While Visiting  
at Home of Sister.

-----  
FUNERAL AT COVINGTON  
ON THURSDAY AFTERNOON.

-----  
Ralph G. Hemingray, 824 East Washington street, prominent manufacturer and one of the city's best known men, died at 5:10 o'clock Tuesday afternoon, at the home of his sister, Mrs. Bradford Shinkle, near Covington, Ky., after a three days illness.

Although Mr. Hemingray had not been in good health for more than two years, he had greatly improved and was feeling as well as usual when he left here Saturday with Mrs. Hemingray for a visit with his sister. However, before arriving at his destination he became ill with pleurisy. Sunday and Monday his condition was so improved that he was thought to have almost recovered from the attack, but early Tuesday morning he suffered a relapse. It was at once apparent that his illness was critical and by noon there was little hope for his recovery.

Came to Muncie in 1889.

The first gas boom in Muncie was an additional incentive for industries to move to the natural gas belt, and in January, 1888, Mr. Hemingray, with his father, Robert Hemingray, and brother, Dan Hemingray, announced their decision to move part of their glass factory here from Covington, Ky. The location chosen by this firm, which has continued as one of the big industries of Muncie, was on Macedonia avenue, where it is now. The elder Mr. Hemingray remained here with the new factory until his death, and since that time Mr. Hemingray had been president and general manager.

During his thirty years of residence in this city, Mr. Hemingray was one of the city's most representative citizens. His great generosity was one of his outstanding characteristics and it would be safe to say his friends are legion. He was a life member of the Muncie Lodge of Elks, was a member of the Rotary Club, and other of the city's leading organizations.

One Daughter in California.

Mr. Hemingray is survived by the widow, Eva; two daughters, Miss Llewellyn Hemingray, of Covington, and Mrs. Phillip W. McAbee, of Muncie, who left with her husband last Thursday for California. Upon arriving in California yesterday they were notified of Mr. Hemingray's death and started east last evening. Two sisters, Mrs. Shinkle and Mrs. Mellie Felix, of Lexington,



Ky., also survive. Funeral services will be conducted from the Shinkle home at 4 o'clock Thursday afternoon and interment will be made in the Highland Cemetery at Covington.

A number of Muncie people will go to Covington Thursday to attend the funeral.

\* \* \* \* \*

Obit for Ralph Hemingray.  
THE (MUNCIE) MORNING STAR  
12 May 1920  
Page 1, col. 3-5  
(Courtesy of Glenn Drummond)

A Good Citizen Gone.

In the passing away yesterday at Covington, Ky., of Ralph G. Hemingray, prominent manufacturer and well known citizen, Muncie suffered a severe shock and a great loss. Mr. Hemingray was held in high esteem by all who knew him, and among his close personal friends he was considered a brother to them all. His heart was as large as the whole outdoors and he did not know what it was to refuse one in distress. His great pleasure was found in doing something for the other fellow. But Mr. Hemingray was one of those whose many acts of kindness go by unnoticed by the public. He was liberal in his views and his liberality extended to his purse to such an extent that he was always found a ready giver to any cause that tended toward the good of the community and the uplifting of humanity. He was a great lover of nature and most of the leisure time of his busy life was spent in the outdoors. The city of Muncie has lost a great benefactor, and humanity a friend whose heart beat always in measured cadence and sympathy with its needs, its desires, its frailties.

\* \* \* \* \*

Obit for Ralph Hemingray.  
THE (MUNCIE) MORNING STAR  
12 May 1920  
Page 8, col. 1  
(Courtesy of Glenn Drummond)

**ESTATE OF MANUFACTURER  
IS VALUED AT \$150,000**

The will of the late Ralph G. Hemingray, former president of the Hemingray Manufacturing Company, who died in Covington, Ky., May 11, was filed for probate in Circuit Court, yesterday afternoon. The widow, Mrs. Eva Hollinger Hemingray, and the daughters, Miss Llewellyn Matthews Hemingray and Mrs. Minnie Carroll McAbee, have filed bond as executrixes of the estate, the value of which is estimated at \$150,000. According to the wishes of Daniel C. Hemingray, of Covington, a brother of Ralph Hemingray who died several years ago, the portions of the estate of the former which were left to the brother in this city are willed to the two daughters, share and share alike, and all other property is left to the two daughters and the widow, share and share alike.

Article about the estate of Ralph Hemingray.

THE (MUNCIE) MORNING STAR

21 May 1920

(Courtesy of Rosella Cartwright)

(Typed version below)

**ESTATE OF MANUFACTURER  
IS VALUED AT \$150,000.**

-----

The will of the late Ralph G. Hemingray, former president of the Hemingray Manufacturing Company, who died in Covington, Ky., May 11, was filed for probate in Circuit Court yesterday afternoon. The widow, Mrs. Eva Hollinger Hemingray, and the daughters, Miss Llewellyn Matthews Hemingray and Mrs. Minnie Carroll McAbee, have filed bond as executrixes of the estate, the value of which is estimated at \$150,000.

According to the wishes of Daniel C. Hemingray, of Covington, a brother of Ralph Hemingray, who died several years ago, the portions of the estate of the former which were left to the brother in this city are willed to the two daughters, share and share alike, and all other property is left to the two daughters and the widow, share and share alike.

\* \* \* \* \*



## Mrs. Hemingray Funeral Sunday

Funeral services for Mrs. Eva Hollinger Hemingray, widow of Ralph G. Hemingray, late president of the Hemingray Glass Company, who died yesterday morning in her apartment at the Delaware hotel, will be conducted at 2 o'clock Sunday afternoon at the Meeks mortuary by the Rev. C. Russell Moody.

Burial will be in Woodlawn Cemetery Monday noon. Friends may call at the mortuary from 5 o'clock until 8 o'clock Saturday night and after noon Sunday.

Born in Terre Haute, Mrs. Hemingray was the daughter of Martin and Eva Mary Fischer Hollinger, pioneers of Terre Haute, a member of the Grace Episcopal Church and was active in Visiting Nurse Association activities, of which she was one of the founders. She was interested in travel, youth education and political science.

Surviving are three nephews, Fred M. Crapo of Muncie, John R. Crapo of Terre Haute and George S. Crapo of Philadelphia, and an aunt, Mrs. Alice Fisher Barcourt of New York City.

\*\*\*\*\*

## Death Claims Prominent Clubwoman

Mrs. Carroll Hemingray McAbee, prominent Muncie clubwoman, died unexpectedly early Wednesday morning in Cocoa, Fla., where she and her husband, Philip W. McAbee, were spending the winter.

She died quietly in her sleep, friends here learned. She had been in poor health for several years and death was believed to have resulted from a heart condition.

Mr. and Mrs. Abee had been in Florida since October. Mrs. Gladys W. Rose, the widow of Frederick D. Rose, Muncie banker, was visiting Mrs. Abee when she died.

Mrs. McAbee was the daughter of Ralph Hemingray, glass manufacturer. She was married in April, 1907, and she and Mr. McAbee had made their residence in Muncie since that date, except for a period of nine years when they lived in Cleveland. The family home is at 824 East Washington street.

Mrs. McAbee's stepmother, Mrs. Eva Hemingray, died here last week. Mr. McAbee is the only survivor. Miss Lewellen Hemingray, a sister, died in Covington, Ky., several years ago.

Mrs. McAbee was a member of the Art Students League, the Conversation Club and the Delaware Country Club.

Funeral services will be conducted by the Rev. C. Russell Moody at 3 o'clock Saturday afternoon at the Meeks mortuary. Friends may call at the mortuary after 1 o'clock the morning of the service. The casket will not be opened. Burial will be in Beech Grove Cemetery.

\*\*\*\*\*

Obit for Eva Hollinger (Mrs. Ralph) Hemingray.

THE MUNCIE STAR

22 Feb 1947

(Courtesy of Rosella Cartwright)

Obit for Mintie Carroll Hemingray (Mrs. Philip) McAbee.

THE MUNCIE STAR

27 Feb 1947

(Courtesy of Rosella Cartwright and  
the Muncie Public Library)

## McAbee Will Establishes Trust Estate

Mrs. M. Carroll H. McAbee, wife of Philip W. McAbee, who died February 26, at Cocoa, Fla., left a will establishing a trust estate, the value of which is not estimated in the formal application by the Fletcher Trust Company, Indianapolis, named trustee. Witnesses to the will, filed yesterday for probate, were Louise Sherman and Fred J. Capp.

The trustee is to pay all taxes incidental to settlement of the estate, and any debts, also expenses of last illness and funeral. Lucille C. Jones of Muncie, is bequeathed \$500. The husband is to receive all jewelry, silverware, automobiles, pictures, the library and household goods, the balance going to the trustee.

The net income of the trust estate is to be paid the husband during his lifetime, the trustee being directed to manage the estate, making collections and reinvestments. If, upon the death of the husband, there remains funds in the trust these are bequeathed in equal shares to Mary V. McAbee of Cleveland, a sister-in-law of the testatrix; and Maude E. Djackstone, a friend, of Waukesha, Wis., or to their heirs, if they are deceased. The trust will terminate upon the death of the husband.

A provision of the will is that no heir is to have the right to pledge, assign, mortgage, sell or to anticipate any share in the trust estate.

\*\*\*\*\*

Article about the will of Carroll H. McAbee.

THE MUNCIE STAR

4 Mar 1947

(Courtesy of Pat Mundy)

## Hemingray Will Creates 2 Trust Funds

The will of Mrs. Eva H. Hemingray, widow of Ralph Hemingray, long a glass manufacturer of Muncie, which provides for disposition of her estate of an approximate value of \$100,000, was admitted for probate yesterday. A cousin, Fred M. Crapo, president of the Indiana Steel and Wire Company, and the Merchants Trust Company are named joint executors and trustees for one of two trust estates created by the will.

Mrs. Hemingray died February 21. The will was written October 18, 1946, and witnessed by J. W. Poorman and W. Eugene Gibson.

Fred M. Crapo is bequeathed in addition to \$15,000 cash all jewelry, household effects, furnishings, rugs and other personal property, including automobiles.

The sum of \$10,000 is to be placed in trust, with Dorothy Conner Crapo of Rushville named as trustee, for the education of the trustee's daughter, Barbara Ann Crapo.

To Amanda Jordan Springer, Chicago, is given \$2,000. The sum of \$1,000 goes to James King Jordan, Chicago.

Elmer Cloyd and his wife, Emma, colored, long employed as help in the Hemingray home, are each to receive sums of \$1,000.

Another trust is created from the residue of the estate. Income from this trust, under the management of Fred M. Crapo and the Merchants Trust Company, is to go to Helen I. Crapo and husband, George Swafford Crapo. At their deaths the income will go to their two children. The trust is to continue for a long period of years.

\*\*\*\*\*

Article about the will of Eva H. Hemingray.

THE MUNCIE STAR

15 Mar 1947

(Courtesy of Pat Mundy)



# Col. Philip W. McAbee Dies Suddenly in South

Col. Phillip W. McAbee, 68, prominent retired Muncie manufacturer, died suddenly at 10:20 o'clock last night at the Andrew Johnson Hotel in Knoxville, Tenn. His death was attributed to a heart attack.

The body will be returned to the Meeks mortuary, where funeral arrangements will be completed.

Colonel McAbee was on his way to his winter home in Melbourne, Fla., when he was stricken. He had left Muncie at 8:30 o'clock yesterday morning with Sgt. Ted Bebout of the Muncie police department, who was driving for him.

### Fatal Seizure at Dinner

Sergeant Bebout said last night that Colonel McAbee was seized with a coughing spell shortly after 9 o'clock in the Hotel Johnson coffee shop as the two were having a late dinner. The colonel collapsed and died an hour later. He had been suffering from a heart

Turn to Page 9, Column 4



COL. PHILIP W. McABEE

He enlisted in 1917, and after attending an officers training camp, he was commissioned captain of infantry. He later became a major, and in May, 1918, he sailed for France, where he was placed in command of the classification camp at Le Mans. He was promoted to lieutenant-colonel in September, 1918, and returned to America the following February. In 1920 he was commissioned a colonel in the Officers Reserve Corps.

Colonel McAbee returned to Muncie, and in June, 1919, was named first vice-president of the Hemingray Glass Company here. He became president in 1920.

In June, 1933, the Hemingray concern was consolidated with the Owens-Illinois Glass Company, and until his retirement in 1933, Colonel McAbee was in general charge of the Muncie insulator division of Owens-Illinois.

### Former Works Board Head

Since his retirement, Colonel McAbee has primarily devoted himself to civic affairs. He served as president of the Muncie Board of Works and Public Safety under the John C. Quick administration, and he was one of the organizers and directors of the local Community Fund.

He was a member of Delaware Post 19, American Legion, and was a former member and past president of the Muncie Rotary Club. An early member of the Whip and Spur Riding Club, he often served as grand marshal at civic parades in the city. He also was a member of the Delaware Country Club.

\*\*\*\*\*

## Col. Philip

### Continued From First Page

condition and asthma for a number of years.

Colonel McAbee's wife, the former Carol Hemingray, died February 26, 1947, at Cocoa, Fla., where she and the colonel were spending the winter.

He had resided at the Delaware Hotel here since selling his home at the northeast corner of Hackley and Washington streets last spring.

The son of Newton S. and Mary Green McAbee, Colonel McAbee was born September 22, 1880, at Cleveland, O. He was educated in the Cleveland public schools and at Phillips Academy, Andover, Massachusetts.

After serving as an accountant in Cleveland in the general offices of the East Ohio Gas Company, he came to Muncie in 1904 and became secretary-treasurer of the Indiana Pipe Company. In 1908 he returned to Cleveland to become associated with the W. B. McAllister Company, general contractors. He remained with that company for nine years, until the United States entered World War I.

Obit for Philip McAbee.

THE MUNCIE STAR

8 Nov 1948

(Courtesy of the Muncie Public Library and Ball State Univ., A. M. Bracken Library, Archives & Special Collections)



**McAbee Funeral Rites  
Wednesday Afternoon**

The funeral of Phillip W. McAbee, 68, prominent Muncie industrialist who died unexpectedly at Knoxville, Tenn., Sunday night, will be conducted in the chapel of Meeks mortuary at 2 o'clock Wednesday afternoon by the Rev. C. Russell Moodey of Grace Episcopal Church. Burial will be in Beech Grove Cemetery. The body will be brought from Knoxville this morning and friends may call at the mortuary this evening. It has been requested that flowers be omitted.

\*\*\*\*\*

Obit for Philip McAbee.

THE MUNCIE STAR

9 Nov 1948

(Courtesy of Bob Stahr)

**Rites This Afternoon  
for Col. Philip McAbee**

Funeral services for Col. Phillip W. McAbee, 68, prominent Muncie industrialist who died unexpectedly at Knoxville, Tenn., Sunday night, will be conducted at 2 o'clock Wednesday afternoon at the Meeks mortuary by the Rev. C. Russell Moodey. Burial will be in Beech Grove Cemetery. Friends may call at the mortuary. It has been requested that flowers be omitted.

Palbearers will be W. P. Zimmerman, M. K. Holmes, C. H. Smith, C. H. Alexander, Robert Pershing, John Maken, Earl Hiatt and Harold Eastus.

\*\*\*\*\*

Obit for Philip McAbee.

THE MUNCIE STAR

10 Nov 1948

(Courtesy of Bob Stahr)

Company ad.

Electric Light & Power  
Jun 1949

(Courtesy of Bob Stahr)



**Hot idea  
for cooling off  
in Kansas**

KANSAS summers are hot, as any Cornhusker knows; but one farmer figured a way to beat the heat! By pumping icy well-water into an old auto radiator and blowing air through it into his home, he found relief in a hurry! Another ingenious use for the greatest rural servant . . . electricity!

Wherever electricity spreads, you will find Hemingray Insulators, dependable always for efficient pole-line insulation.



No. 670 for 12,000-volt lines. The Technical Standards Committee of the Rural Electrification Administration has approved Hemingray Insulators No. 670, No. 680, and No. 514, under the limits of AIEE Specification No. 41-1944 for use on REA lines.

**HEMINGRAY  
POWER INSULATORS**

American Structural Products Company  
Muncie, Indiana

Subsidiary of Owens-Illinois Glass Company





## THE HEMINGRAY SILVER

In the spring of 1975 a Covington news story reported that Harry Lowe, president of the First National Bank in that city, had discovered a leather pouch of silver belonging to Dan Hemingray in the bank vault. Nearly 400 visitors viewed the rare silver at the Ft. Mitchell Country Club. Below is a copy of the card issued to visitors when the contents of the pouch were displayed. Could pieces of this silver be some of those presented to Robert and Mary Carroll Hemingray on their 50th wedding anniversary in June of 1892?



### The Hemingray Silver

---

The Hemingray Silver was left in the vault of First National Bank for safekeeping. The exact date is unknown but a newspaper found with the silver bears a 1907 date.

The Hemingray family apparently traveled considerably for the leather bag with the silver was placed bears stickers from hotels in Ireland, France, Holland, Germany and Italy.

Search of local records indicates that Daniel Carroll Hemingray was married to the former Clara Keck. They had no children. Mr. Hemingray died in 1911 and his wife was his survivor. Mrs. Hemingray died in 1943 and left a brother in New York and a sister in Corpus Christi, Texas.

While residents of Covington, the Hemingrays lived on the northeast corner of Seventh and Greenup Streets. Later they moved to Glendale, Ohio.

Mr. Hemingray was secretary-treasurer of the Hemingray Glass Co., a member of the board of the Suspension Bridge company and of the Covington Water Board. He received his higher education at the Massachusetts Institute of Technology.

In addition to the Hemingray Glass Co. plant in Covington, the family also had a plant in Muncie, Ind.

Mr. and Mrs. Hemingray are buried on the family lot in Highland Cemetery.

Copy of the card issued to visitors when the Hemingray silver was displayed at the First National Bank.  
Covington, KY  
Spring 1975  
(Courtesy of Glenn Drummond)

TRADE MARK  
STANDARD HEMINGRAY INSULATORS  
REGISTERED.





# HEMINGRAY PLACES

## PART II



CD 113

THE UNIVERSITY OF CHICAGO PRESS

THE UNIVERSITY OF CHICAGO PRESS

THE UNIVERSITY OF CHICAGO PRESS



# HEMINGRAY PLACES

## PART II

Having learned something about the Hemingray people, now it's time to learn about Hemingray places. This includes their factories and homes. It will be necessary to repeat some information from Part I, but I'll try to keep it at a minimum.

### SETTING THE SCENE

Hemingray first set up shop in Cincinnati, Ohio, in 1848, 149 years ago at this writing. At that time James K. Polk, the 11th president, was in the White House. Abraham Lincoln was 39 years old, and wouldn't be elected president for another 12 years. The Mexican War was raging, and the Civil War was 13 years in the future.

Of the three Hemingray factory sites, I have visited two; Coving-

**GRAY & HEMINGRAY<sup>1</sup>**  
THE CINCINNATI YEARS

DIRECTORY YEAR	ANTHONY GRAY	RALPH GRAY	ROBERT HEMINGRAY	SAMUEL HEMINGRAY	LOCATION OF WORKS, WAREHOUSE, OFFICE
1849-1850	bds. <sup>2</sup> Ralph Gray	w.s. Sycamore b. 3rd and 4th	w.s. Sycamore b. 3rd and 4th	bds. Robert Hemingray	Glass Manuf., Hammond St.
1850-1851	—	26 w. Fifth	26 w. Fifth	—	Flint Glass Manuf., e.s. Hammond.
1851-1852	n.s. New e. Broadway	bds. Robert Hemingray	n.s. 5th b. Broadway and Pike	114 Symmes	Flint Glass Manuf., e.s. Hammond.
1853	—	Res. Covington	Res. Covington	b.k. at Gray & Hemingray's. h. s.s. New e. of Broadway	Flint Glass Manuf., warehouse e.s. Hammond.
1855	—	Res. Covington	Res. Covington	b.k., res. New E. of Broadway	Flint Glass Manuf., e.s. Hammond b. 3rd and 4th.
1856	—	Res. Covington	Res. Covington	clk., Hammond b. 3rd & 4th., res. Covington	Flint Glass Manuf., Hammond b. 3rd & 4th, Factory, Covington, Ky.
1857	—	Res. Covington	Res. Covington	Res. Covington	Manufacturers of Flint Glass. Warehouse 14 Main.

1 Data extracted from Williams' Cincinnati Business Directory. All information is identical to directory entries.

2 Abbreviations; w.s., "west side"; n.s., "north side"; s.s., "south side"; e., "east"; b., "between"; bds., "boards"; h., "home"; res., "residence"; b.k., "bookkeeper"; clk., "clerk".

Locations of Gray's and Hemingray's residences, glassworks, warehouse, and office.

1849-1857

Chart drawn by Glenn Drummond.  
(Courtesy of Glenn Drummond)



Map of eastern United States.  
 (From right to left, dots show Pittsburgh,  
 Cincinnati, Covington, Muncie, and St. Louis.)

ton and Muncie. It really helped to get a feel for the history to see the actual sites. I saw how close the company actually was to the Ohio River in Covington, and felt the hot muggy summer air. In Muncie I saw how really large the property was, and in what part of the city the factory sat.

Esther M. Power summed up the details of the three sites this way, in her excellent article in The Antique Trader Weekly, 17 August 1976:

*Because the company had overlapping and succeeding locations and because manufacturing was done in one place and a warehouse kept elsewhere, confusions have arisen. In brief, the general picture is this: the early Cincinnati years were followed by a period when the warehouse was located in Cincinnati but production took place across the river in Covington; then came years when all operations*





Close-up of north central United States showing locations mentioned in story.  
1. Pittsburgh; 2, Cincinnati; 3, Covington; 4, Muncie; and 5, St. Louis.

*were in Covington, followed by years with offices in Covington and production in Muncie, Indiana; and finally, a period when all operations were moved to Muncie.*

## **PENNSYLVANIA**

The Hemingray name is first associated with glassmaking in Pittsburgh, Pennsylvania. Just how extensively they were involved, and what glassmaking house they worked for, isn't known by me for certain. What seems likely is that both the Grays and Hemingrays had some knowledge of glassmaking when they arrived in Cincinnati.

## **CINCINNATI, OHIO**

**~ THEN ~**

*Glass works.*—Two; value of product, forty thousand dollars; employ thirty hands.

The largest of these, that of Gray & Hemingray, is on a scale so much inferior in magnitude to those of Pittsburgh, that the statistics just given, would have concluded this subject, but for the conviction which the writer of this entertains, that Cincinnati will hereafter lead Pittsburgh in cotton fabrics, rolling mill products and glass manufactures, as we already do in everything else. It becomes, therefore, an object of interest and solicitude to examine the details of what it is evident, is the germ here, of a vastly important branch of industrial pursuit, as suggestive of the great future. Sand, pearl-ashes, and lead, are the main constituents of glass. The sand necessary for glass works in Pittsburgh and Cincinnati, is brought from Missouri, and the lead from Illinois, both at less expense to this point, than to Pittsburgh; and the pearl-ash, always runs in price lower here, than in the markets of our sister city.

Nor is this all; the means of living here, are lower than at Pittsburgh, every item but rent, being so much cheaper, as to more than equalize general expenses. In this state of the case, and with the rapidly growing business of this establishment as an encouragement, other glass works must spring up; and as their operations enlarge, a point of purchase in these articles will be created, which must concentrate large sales of glass here, of city product, which have heretofore been made elsewhere.

Gray & Hemingray, make tumblers, decanters, packing-bottles, lamp glasses, apothecary shop furniture, and generally, most articles manufactured in Pittsburgh. A greater variety of perfumery glass is manufactured in these works, than at any in Pittsburgh. All the operations alluded to, are of flint glass, except insulators, which are made for lightning rods and for telegraph lines, here, and at Pittsburgh; which place is entirely supplied from this point.

Description of Gray & Hemingray  
from Sketches and Statistics of Cincinnati,  
by Charles Cist.

1851

(Courtesy of Glenn Drummond)



Not much information has come to light as of this date on the company's location on Hammond Street in Cincinnati. What we do know is that the Gray brothers, Anthony and Ralph, and the Hemingray brothers, Robert and Samuel, came to Cincinnati from Pennsylvania in 1847. Along with some glassmaking experience, they apparently had sufficient capital to open a glassworks and make it a success. One year after their arrival, in 1848, they opened their small glassmaking shop on the east side of Hammond Street, a small street that ran north and south from Third to Fourth Street between Main and Sycamore. Gray & Hemingray leased an existing building and modified it for their glassmaking. As to who among them was the glassmaker, it was likely Robert Hemingray. Evidence indicates that Robert had glassmaking experience and it isn't known whether Anthony or Ralph Gray did; and Samuel's background does not suggest that he would have been involved in glass manufacture prior to the start of the Cincinnati operation. (He became the company bookkeeper.) It is unknown what role the others played in the early years of the business.

Before getting into the business itself, it is interesting to understand just why Cincinnati was their chosen destination. There were several factors involved. First of all, the potential in this area for a successful business venture was great, for in 1848 Cincinnati was the fifth largest city in population in the United States, with slightly over 90,000 residents. Only New York, Boston, Philadelphia, and New Orleans were larger. Cincinnati at that time was called the "Queen City of the West", and because of its extensive

**Glass Works.—Gray, Hemingray & Bros., employ eighty hands ; value of product, one hundred thousand dollars.**

**This is equal to any establishment in Pittsburg, in importance, and excels any there in the variety of articles which it manufactures. To enumerate the principal ones only, would be to furnish a general and extensive catalogue ; many of these are peculiar to their works: such as glass milk pans, atmospheric fruit jars, etc.**

**Every description of flint glass ware, apothecaries' furniture, and chemical apparatus made to order on short notice. Perfumers' ware, telegraph glasses, and lightning rod insulators. Patent self-adjusting lanterns for railroads, steamboats, and for general purposes.**

Description of Gray, Hemingray, & Bros.  
from Sketches and Statistics of Cincinnati,  
by Charles Cist.

1859

(Courtesy of Glenn Drummond)



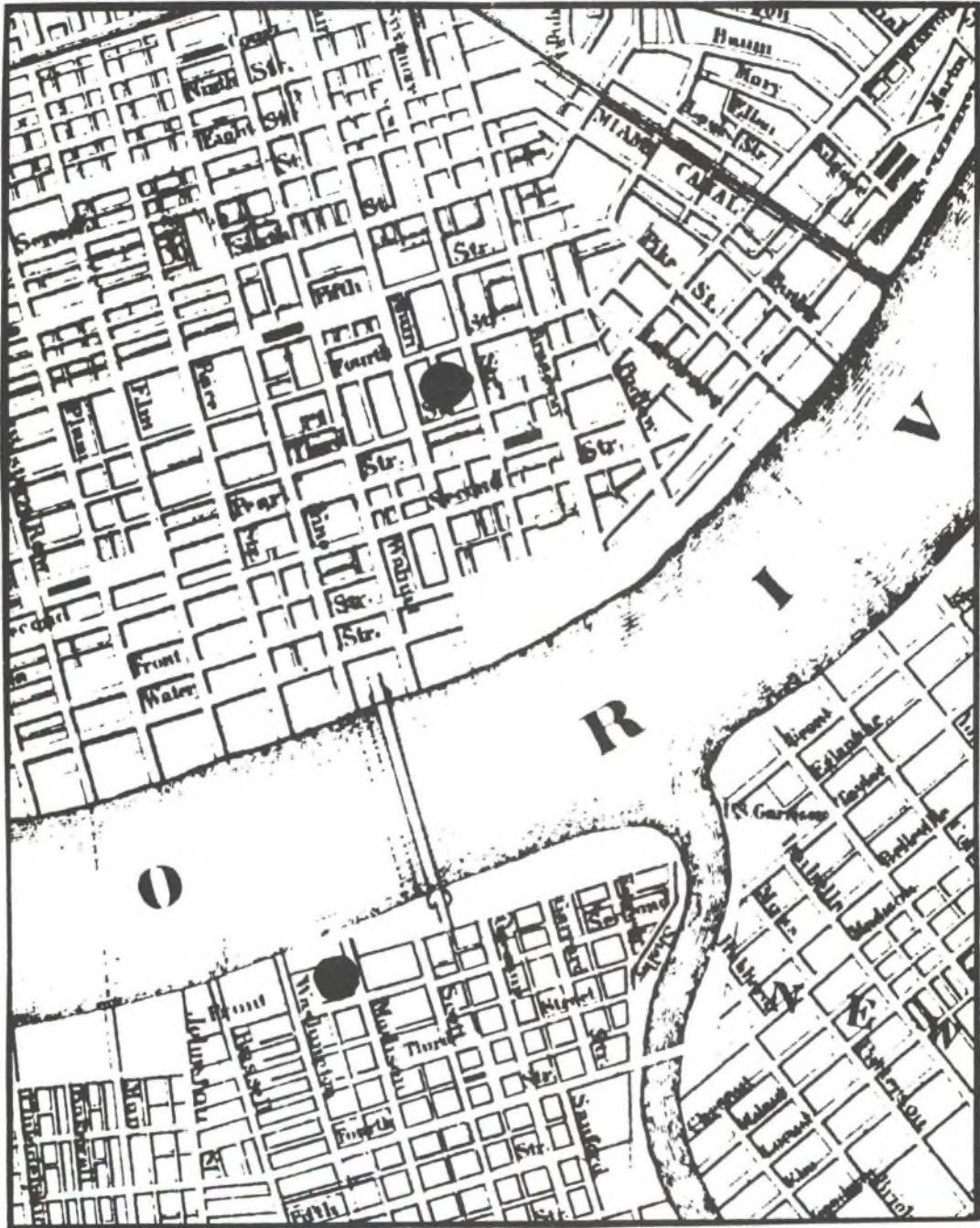

Cincinnati and Covington (dots show factory sites).  
Williams' Cincinnati Directory  
1860  
(Courtesy of Glenn Drummond)

commerce, it was an objective for the rival telegraph companies fighting for the West at that time. Although this probably was not the reason why the Hemingrays and Grays came to Cincinnati, the Panic of 1837 caused many businesses to close back east. Those without jobs there looked to the west with new hope.



Cincinnati was a frontier town at the time the two families came there. Animals, including pigs, ran free in the streets. Buckskin-clad men came out of the mountains to trade their furs and mixed with the immigrants from Germany and Ireland. Slavery was prohibited in Ohio, so many free blacks settled in the area.

Ohio had been a state since 1803, so already there were many industries and factories in Cincinnati. It was a thriving bustling place to set up a business. Being right on the Ohio River made the shipping and receiving of goods fairly easy and financially possible for the local businesses.

Cincinnati was a melting pot for people from the North, South, East, and West, and all were accepted, as a rule. But of the four sections, the town had a more Southern feel to it.

So this was the Cincinnati to which the Hemingrays and Grays came in 1847, and in which their glassmaking house was opened a

**R. HEMINGRAY & CO.,**  
**No. 68 Walnut St., Cincinnati, O.,**  
**MANUFACTURERS OF**

**FLINT, GREEN & BLACK GLASS,**

CONSISTING OF

**Fruit Jars, Lamps, Lanterns, Chimneys, Brandy, Mock Wines, Demi-Johns, Screw Cap Flasks, Tumblers, and a general variety of Table Ware. Also, Philosophical Apparatus, and Round & Oval Shades for Artificial Flowers and Statuettes. Solar, Sun and Comet Burners on hand in large quantities.**

N. B.—Our **PATENT FRUIT JARS**, manufactured exclusively by us, stand unrivaled for preserving qualities, and have the best reputation of any Jar in the West.

**LIBERAL DISCOUNT TO THE COUNTRY TRADE.**

Ad for R. Hemingray & Co.  
Williams' Cincinnati Directory  
& Business Advertiser

1868

(Courtesy of Glenn Drummond)

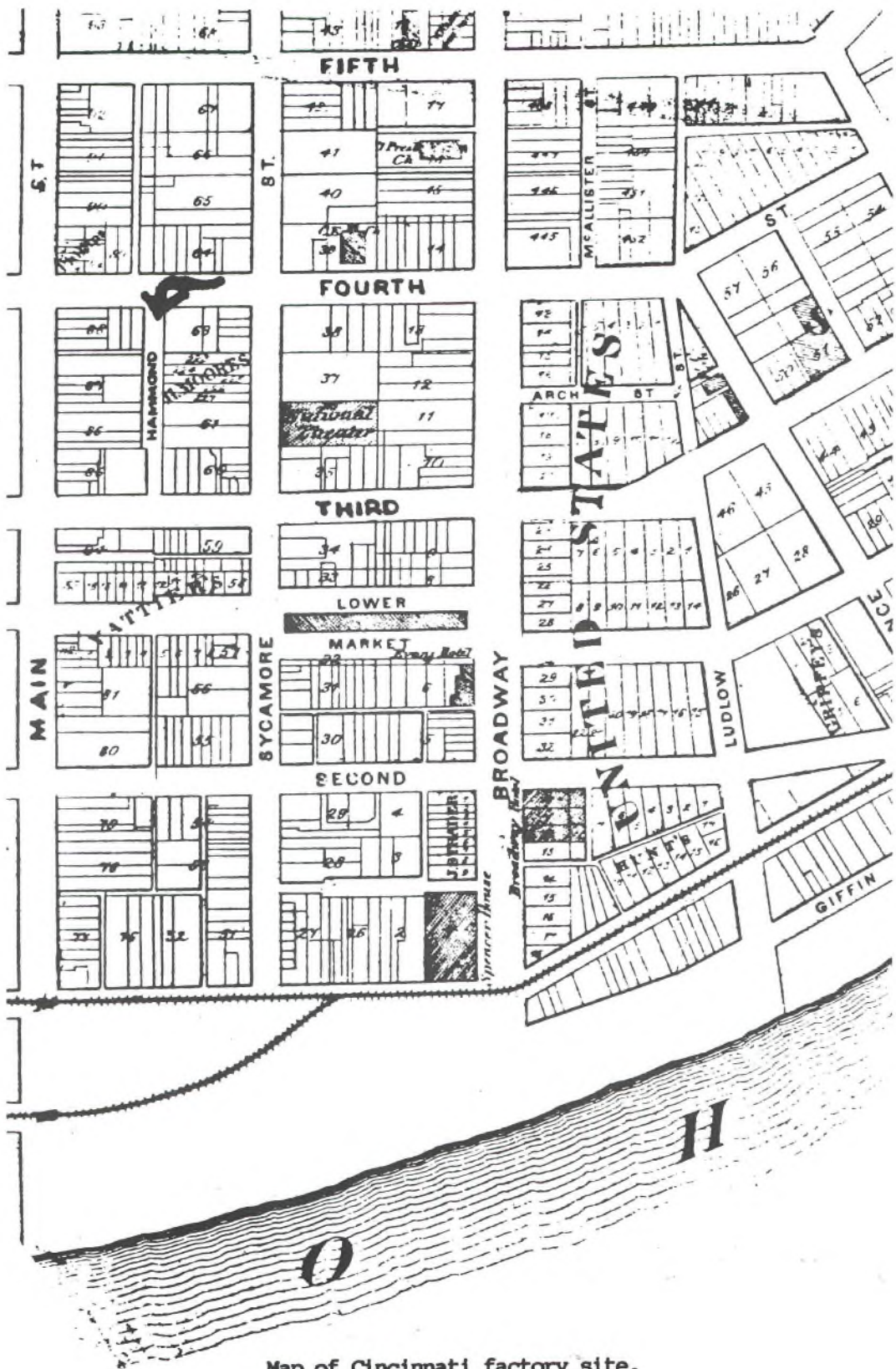

Map of Cincinnati factory site.  
 (Arrow shows Hemingray location.)  
 Titus' Atlas, Hamilton Co., OH  
 1869  
 (Courtesy of Glenn Drummond)



GREY & HEMINGRAY,

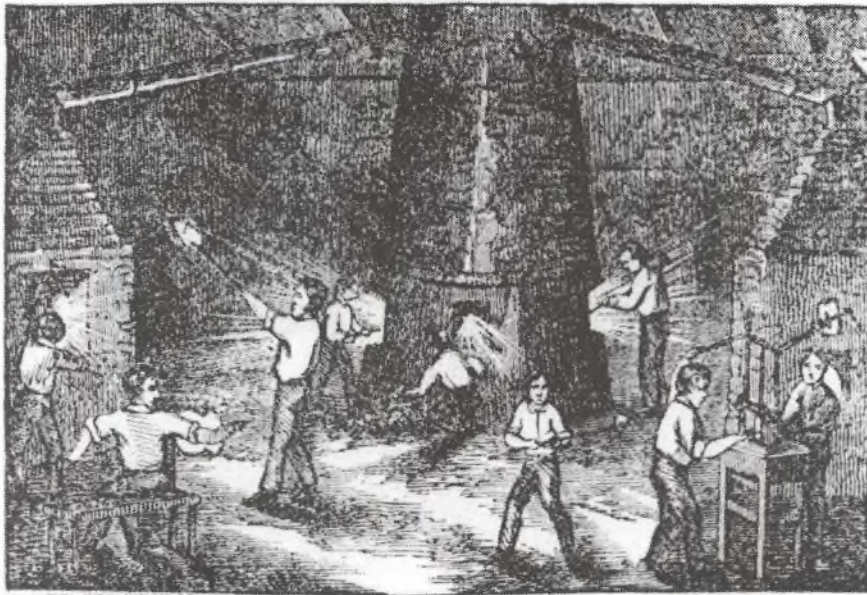

FLINT GLASS  
**MANUFACTURERS**

Hammond Street, bet. Third and Fourth, Cin:

Keep constantly on hand every variety of

FLINT GLASS WARE,

Apothecary's Furniture, and Chemical Apparatus made to order at  
the shortest notice. Also, a great variety of Perfumers'  
Ware, Telegraph Glasses and Lightning Rod Insulator.

Ad for Gray & Hemingray  
showing the interior and furnace at Hammond St.  
Gray's Cincinnati Business Mirror & City Advertiser  
1851-1852

(Photo B-95-206 courtesy of the Cincinnati Historical Society)

year later. The first of six names by which the company would be known was "Gray & Hemingray". Advertisements for this early Hemingray endeavor exist today and can be seen elsewhere in this book. Hammond Street was four or five blocks up the hill from the Ohio River, and at least three blocks from the railroad tracks. These factors were probably a detriment, as this location proved to be quite a ways from access to easy transportation. Supplies for glassmaking, and products from the company, had to be hauled by wagon several blocks to pickup and delivery points, most of the distance being up or downhill.

To date there have been no records or photos found of the Hammond Street location, but on the previous page is a drawing of the furnace area in the interior of the building, drawn for an 1851-1852 company ad. By 1853 Gray & Hemingray had made their first of three moves; across the Ohio River to Covington, Kentucky. So they were at Hammond Street for only about five years.

## CINCINNATI, OHIO ~ NOW ~

The buildings around the original Hammond Street site have been replaced perhaps as many as three times since first owned by Gray & Hemingray. Now Hammond Street runs east and west with an offset, while in 1853 it ran north and south. It isn't known when the layout was changed. The Park, Cincinnati Bell Building, and the Johnson Electric Building have been replaced by the Atrium 2 Building. A large newly constructed (1980s) office building has eliminated the original Hammond Street, but the street name still exists, and is still a short street, but runs the opposite way.

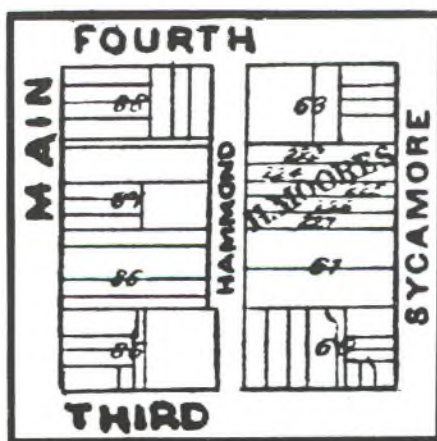

Map of Cincinnati factory.  
Titus' Atlas of Hamilton Co., OH  
1869  
(Courtesy of Glenn Drummond)

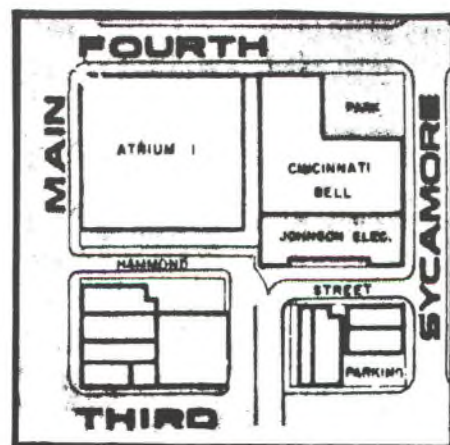

Map of Cincinnati factory site.  
The Cincinnati Daily Inquirer  
Oct 1984  
(Courtesy of Glenn Drummond)



**GRAY & HEMINGRAY,  
FLINT GLASS MANUFACTURERS.**  
*Hammond Street, between Third and Fourth,  
CINCINNATI.*

Keep constantly on hand every variety of **FLINT GLASSWARE**. Apothecary's Furniture, and Chemical Apparatus made to order at the shortest notice.

—ALSO—

**A great variety of Perfumer's Ware, Telegraph Glasses, and Lightning Rod Insulators.**

Ad for Gray & Hemingray.  
Cist's Advertiser  
30 Jul 1852 through 29 Apr 1853  
(Courtesy of Glenn Drummond)

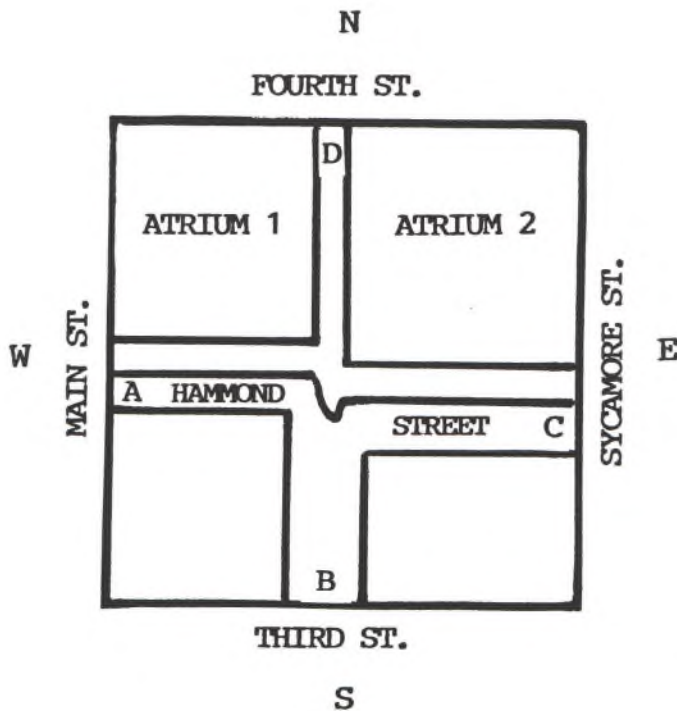

Map on Cincinnati factory site today.  
Letters indicate locations in photos  
on pages 96 and 97.  
(Map dimensions are approximate.)



Hammond Street, Cincinnati, OH  
Main Street, foreground, Atrium 1 at left, Atrium 2  
in center background, looking east.  
(Location A on map)  
28 May 1992  
(Courtesy of Franklin Jaquish)

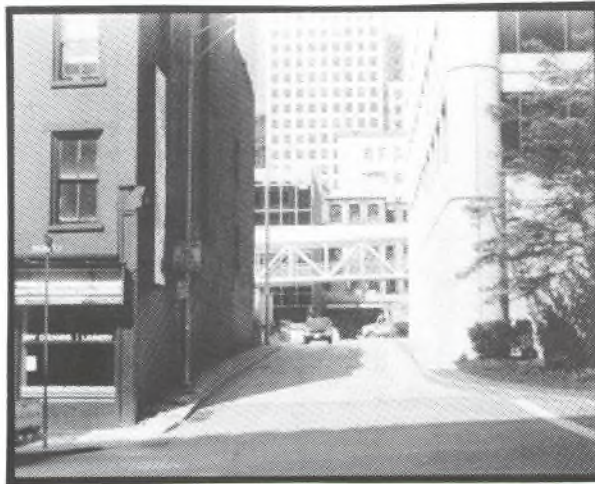

Hammond St., looking west.  
Sycamore St. in foreground.  
(Location C on map)  
28 May 1992  
(Courtesy of Franklin Jaquish)



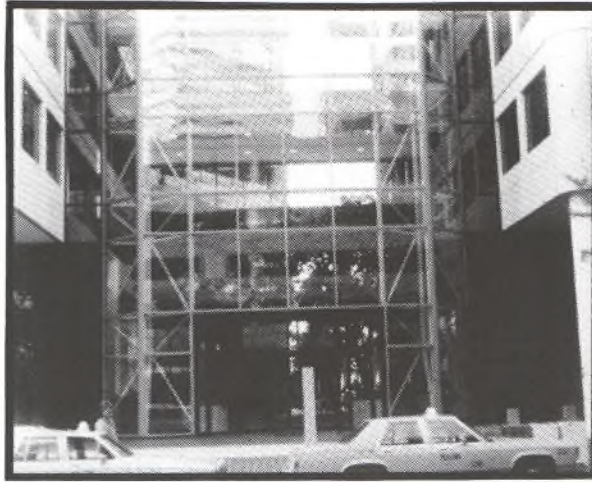

Same. Old Hammond St. would have gone behind  
center post. Looking south from Fourth St.  
(Location D on map)  
28 May 1992  
(Courtesy of Franklin Jaquish)

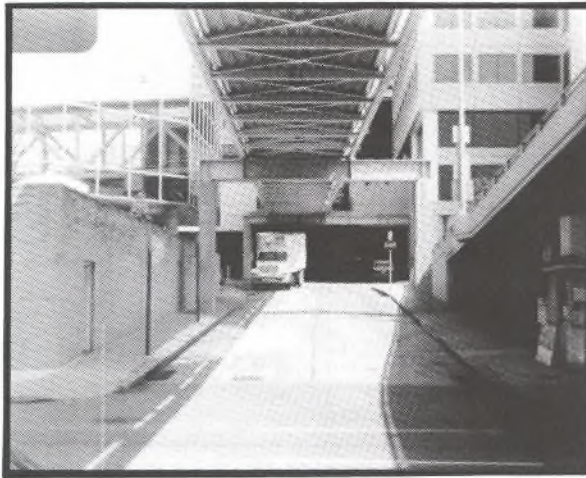

Same. Old Hammond St. would have been a few feet  
to the right. From 3rd St. (foreground), looking north.  
(Location B on map)  
28 May 1992  
(Courtesy of Franklin Jaquish)

# COVINGTON, KENTUCKY

## ~ THEN ~

Ralph Gray and Robert Hemingray bought the property at 2nd and Madison Streets together. The deed and mortgage were written on 20 August 1852. The deed doesn't indicate that there were any buildings on the site other than a stable. (Any other buildings would probably have been listed on the deed.)

It is hard to say just how long it took to construct all of the buildings, furnaces, etc., but it was probably finished by very late 1852 or early 1853. However, Covington didn't become the sole base of operation until about early 1856. So the complete move took several years. It was noted on the mortgage that the debt was paid

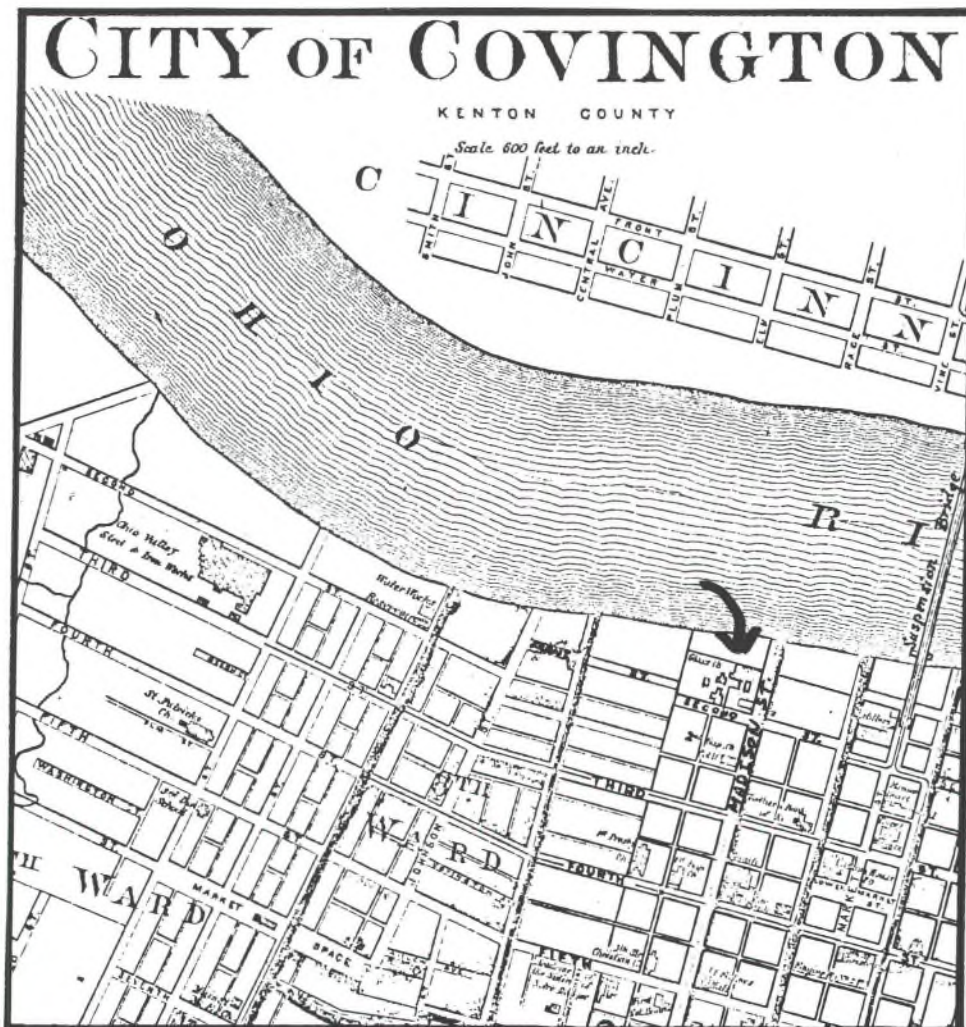

Map of Covington factory site (arrow).  
An Atlas of Boone, Kenton, and Campbell Counties, KY,  
D. J. Lake & Co.  
1883  
(Courtesy of Glenn Drummond)



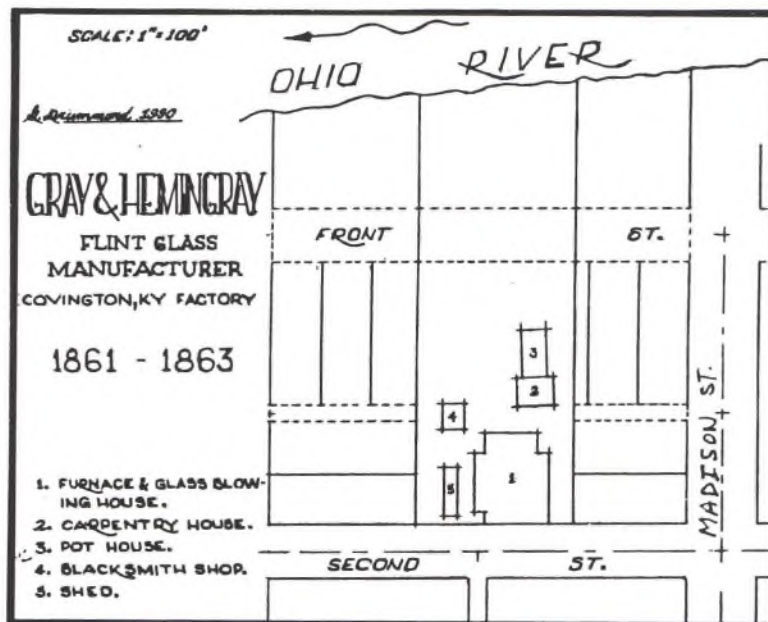
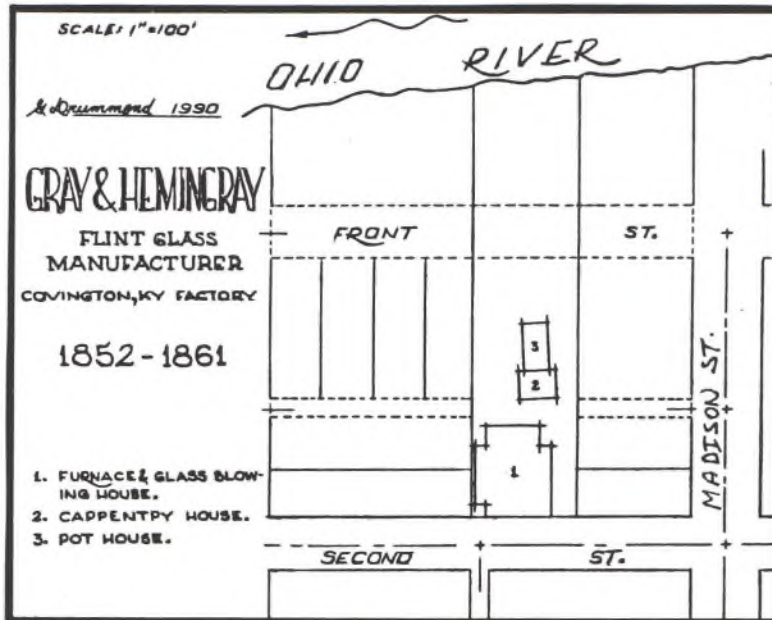

Maps drawn by Glenn Drummond showing the Covington factory site.  
 1852-1861 and 1861-1863  
 (Courtesy of Glenn Drummond)

on 18 April 1863. That was about ten years, although the terms of the mortgage gave them 12 years. This early payment would suggest that the business was doing pretty well.

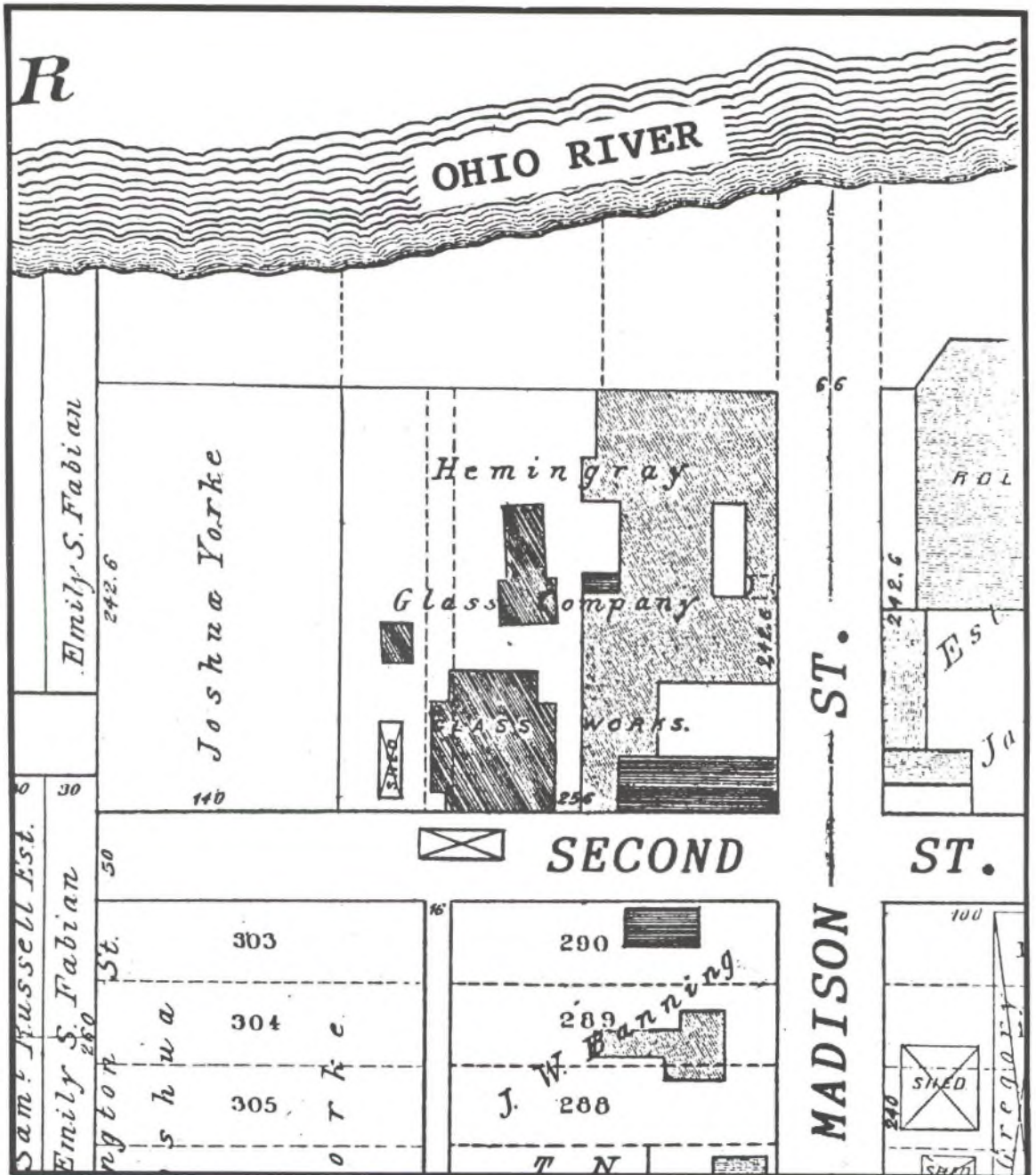

Map of Covington factory.  
 City Atlas of Covington, KY  
 1877  
 (Courtesy of Glenn Drummond)

The last listing in the city directory of any connection to Hammond Street was in 1856. In 1857 and 1858, 14 Main Street was listed. From 1859 through 1867, a warehouse is listed at 20 E. 2nd,



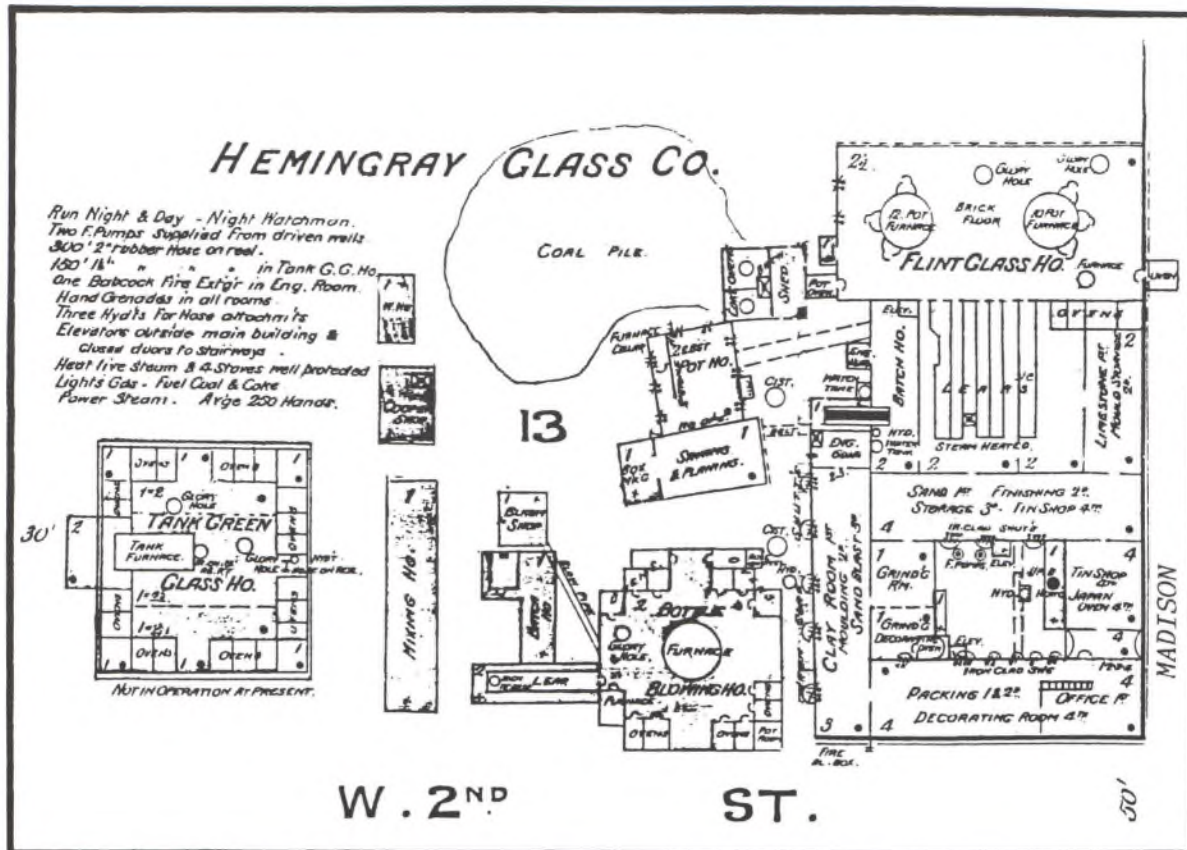

Sanborn Insurance map of the Covington factory  
 at the NW corner of 2nd and Madison.

1886

(Courtesy of Bob Stahr)

THE SANBORN MAP COMPANY

Starting around 1867, the Sanborn Map Company of Pelham, New York, began producing maps for various insurance companies' use. These maps helped determine insurance rates and were a permanent record of insured buildings.

These maps are very artistic and detailed, with color codes on the maps indicating types of building construction. They are hand-drawn, colored, and the lettering is quite stylish. Symbols indicate such things as the height of the building, and some interior items such as furnaces, types of fuel used, water lines, and fire hydrants. The coding pretty much covers all of the infrastructure on the property. These maps, preserved in libraries and historical societies, have been a tremendous help to historians and researchers, and are often the only surviving record of the layout of historical buildings long gone.

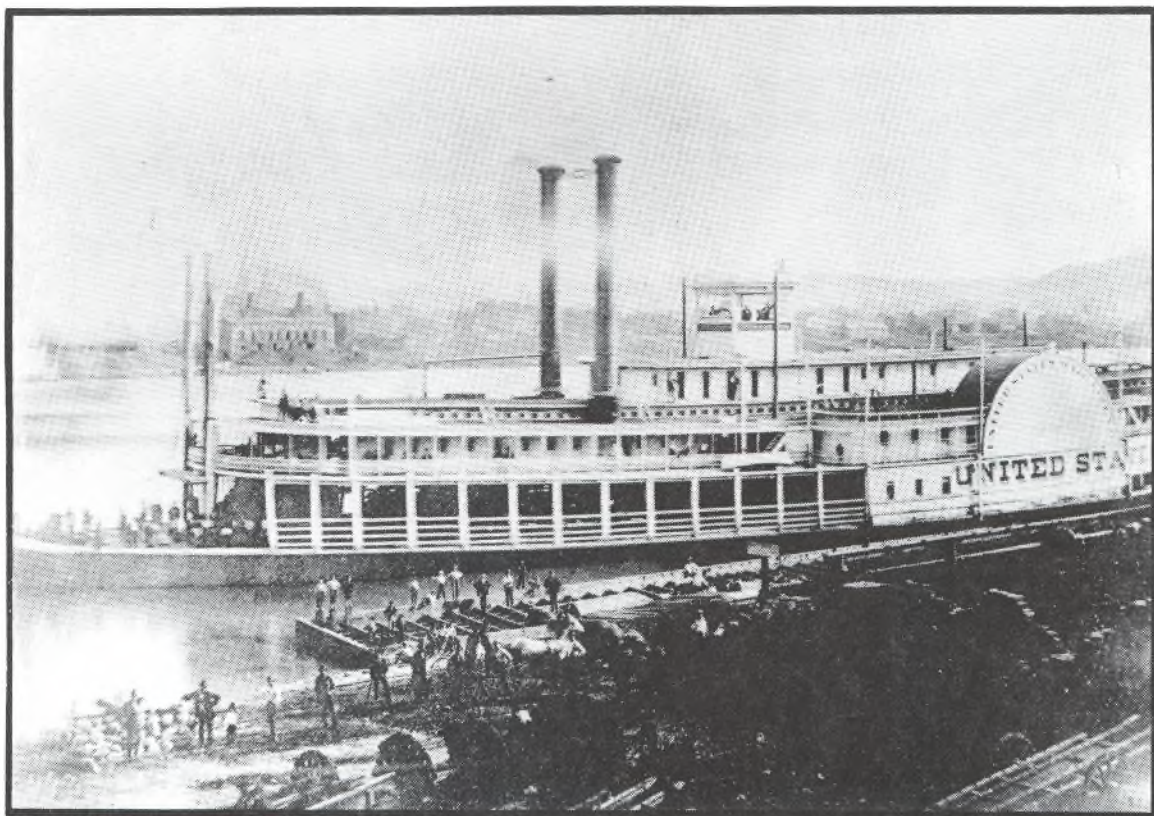

Long view of the Covington factory looking south from Cincinnati.  
Building is at left center.

C. 1868

(Photo B-79-021 courtesy of the Cincinnati Historical Society)

#### NOTES ABOUT THE "UNITED STATES"

The sidewheeler "United States" seen in this photo was built in Cincinnati in 1865, and was owned by the U. S. Mail Line. She was involved in several accidents, but on the night of 4 December 1868 she collided with her sister ship "America" above Warsaw, Kentucky, burned and sank. Sixty-three people died. She was rebuilt and went back in service in 1869, experiencing another collision in December 1877. She was dismantled at Madison, Indiana, in February 1884.

I believe that this photo shows the first ship before being rebuilt, which would date the photo at 1865 to 1868. It is obvious that the Hemingray Glass Company seen in the background was rebuilt after this, or at least the smokestacks were, for they are taller than this in the similar photo dated in the 1880s.

From Way's Packet Directory, 1848-1983, by Frederick Way, Jr.  
(Courtesy of the Cincinnati Historical Society)



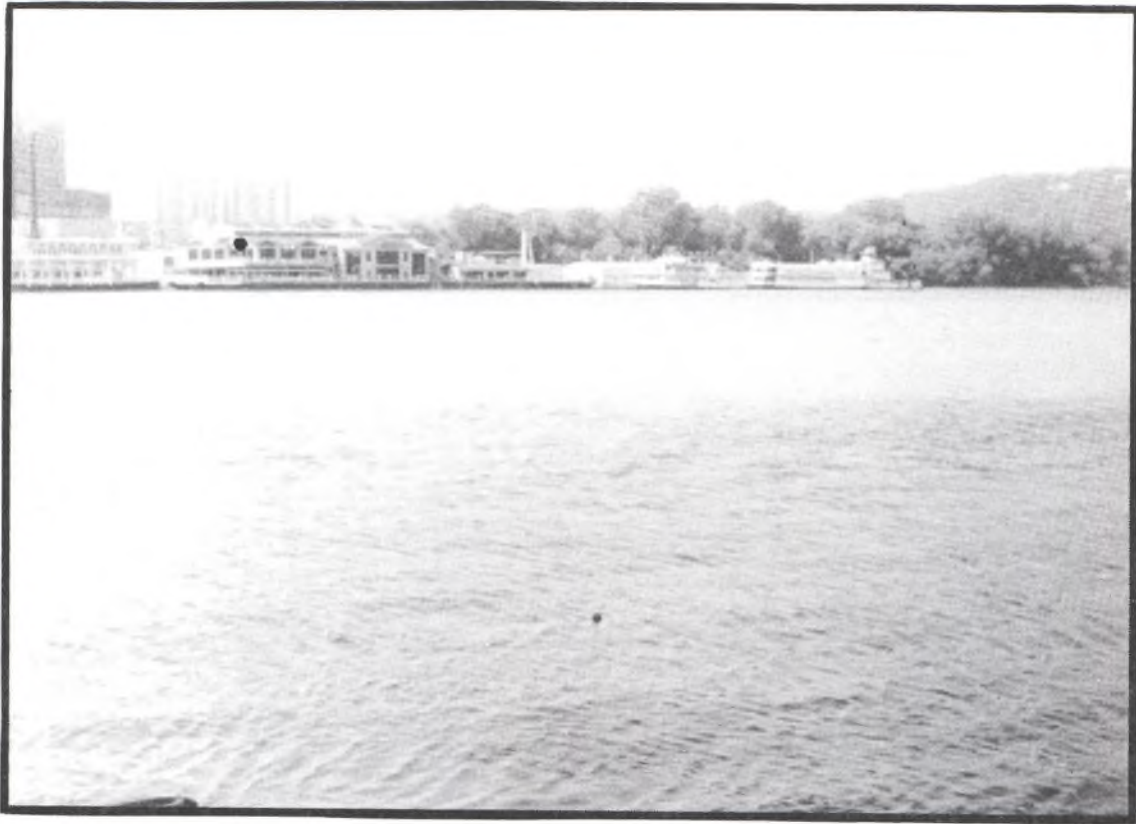

The same scene today.  
(Dot marks the Hemingray Glass Co. site in Covington.)  
28 May 1992  
(Courtesy of Franklin Jaquish)

and at 68 Walnut from 1868 to 1881, all in Cincinnati. These were probably "ware rooms" or storage areas, perhaps even showrooms.

The maps of Covington shown a few pages back, drawn by Glenn Drummond, show a few structures, but the Sanborn Insurance Map for 1886 on page 101 shows the following: Cooper shop, flint glass house, grinding room, tin shop, packing and decorating room, office, sand storage, finishing room, clay room, lehrs, bottle-blowing house, green glass house, glory holes, blacksmith shop, sawing and planing building, and ovens.

The offices as well as the glassmaking plant occupied the northwest corner of 2nd and Madison in Covington. The company remained at this location from about 1853 until 1890, and expanded on this site as business increased. In an historical article by Jim Reis in The Kentucky Post, dated 1 June 1992, he states, "In November 1872...workers were temporarily thrown out of work when a fire whipped by high winds raced through the Hemingray warehouse at the foot of Madison Avenue. The fire spread quickly because the finished glass-

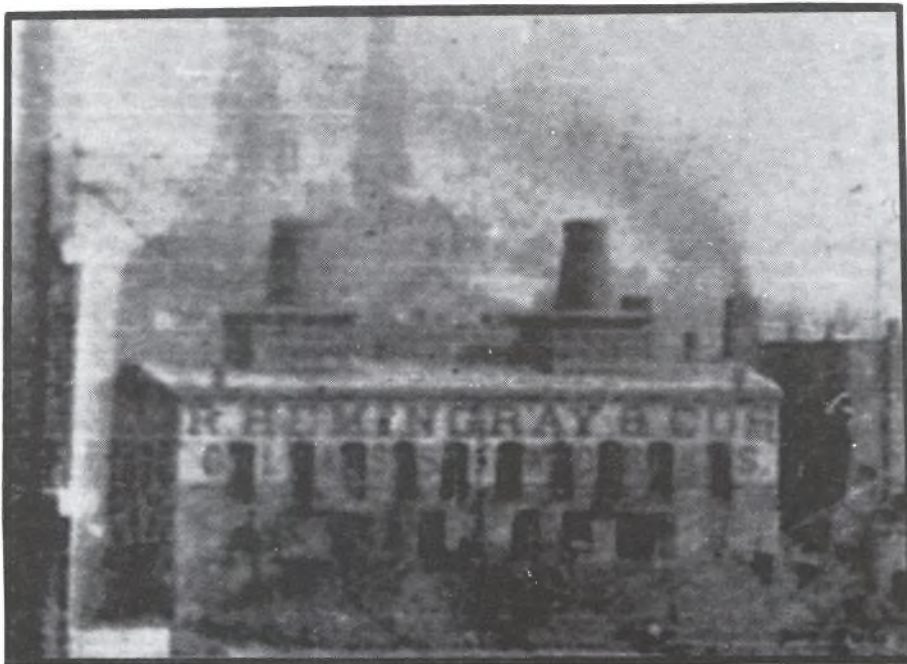

Close-up of Covington factory looking south.

C. 1868

(Photo B-79-021 courtesy of the Cincinnati Historical Society)

ware was stored in crates packed with straw. A new glass works building was built in 1881. The facility was enlarged along Second Street by the transfer of Hemingray's showroom from Walnut Street in Cincinnati."

The Daily Commonwealth of Covington tells of the newly constructed building there on 1 February 1881. This is in all probability one of the structures still on the site until 1981, and which will be mentioned more in detail later on.

**THE new Hemingray Glass Works building on Second Street is completed and the store of the firm, heretofore on Walnut street, in Cincinnati, will be removed to the new and commodious building adjoining the factory in this city.**

Article about the company's move to Covington.

The Daily Commonwealth

Covington, KY

1 Feb 1881

Restored by Carol McDougald.

(Courtesy of Glenn Drummond and Carol McDougald)



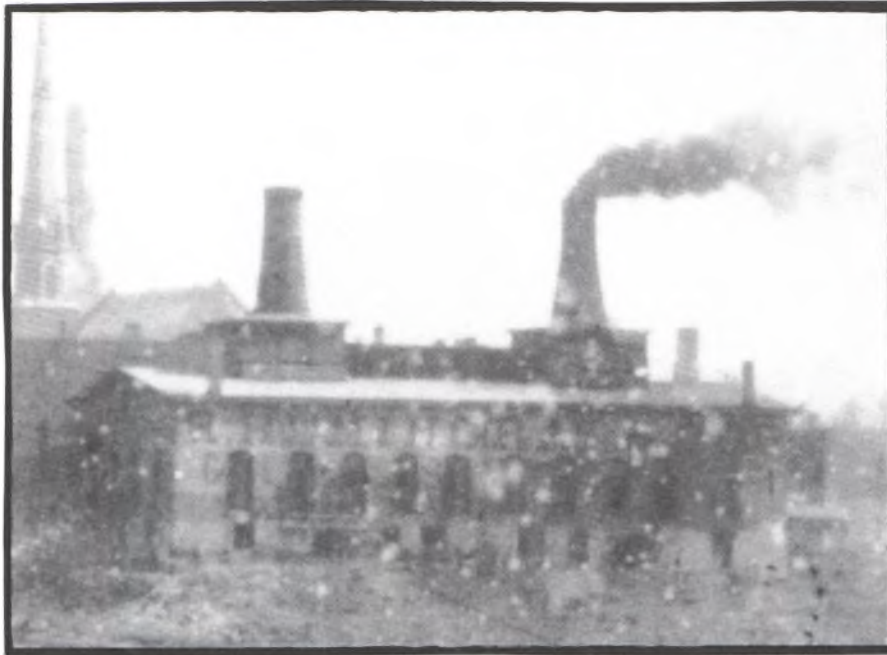

Close-up of Covington factory looking south.  
C. 1880  
(Courtesy of the Cincinnati Historical Society)

The Covington location had several advantages over the old Hammond Street site. This new location right along the riverfront was more practical, and in those days river barges were an economical means of transporting coal, sand, and the other heavy material used in glassmaking. The river also provided a low cost method of distributing the company's products, as the barges could come up to within feet of their doors. This move gave immediate access to the railroads and the river.

In the approximately 85 years of the company's existence it was known under six different names. (See page 4 ) Several factors caused the name changes. When Anthony Gray and Samuel Hemingray joined the company in 1857, the name was changed to "Gray, Hemingray & Bros.". When Anthony Gray became inactive in the business in 1861 (probably due to ill health, as he died in 1865), the name became "Gray, Hemingray & Bro.". Ralph Gray died in late 1863, and in 1864 Robert and Samuel Hemingray, who were brothers, changed the name to "Hemingray Bros. & Co.". The "Co." included Richard Evans and James Foley. (Evans was married to Mary Hemingray, sister of Robert and Samuel.)

In September 1866 Samuel died. In the Covington directory for 1868-1869 we discover the fourth name change, to "R. Hemingray & Co.", which apparently lasted about two years. It was around this time (1868) that a photo was taken showing the Covington factory from the Cincinnati side of the river, for the words "R. Hemingray and Co. Glass Works" are faintly visible on the side of the building. This same name appears on a later photo also. (See above) In 1870

the company was incorporated and the name was changed to the "Hemingray Glass Company". This name remained unchanged for the final 63 years of the company's existence. (See incorporation papers on page 393.)

The Covington years were prolific ones for the Hemingray Glass Company. Although insulators were not their only product, demand increased to the point where it soon became their main concern. Railroads were expanding, creating the need for insulators for signal lines. The telegraph was being strung to more and more areas of the country. The invention of the telephone brought increased need for insulators. Also, as the knowledge of how to transmit higher voltages of electricity evolved, this brought greater demand for larger and heavier insulators. The company was hard put to keep up with their orders, even working around the clock.

As these industries gained in importance in the late 1890s, the company began to concentrate more on the manufacture of insulators to better serve the increasing demands. The Hemingray Glass Company soon became known the world over as the leading producer of glass insulators. Their insulators carried the company's name to most of the American continent as well as to almost every civilized country in the world. Insulators remained the mainstay of the company until the mid-1920s (at which time bottle production was reinstated).

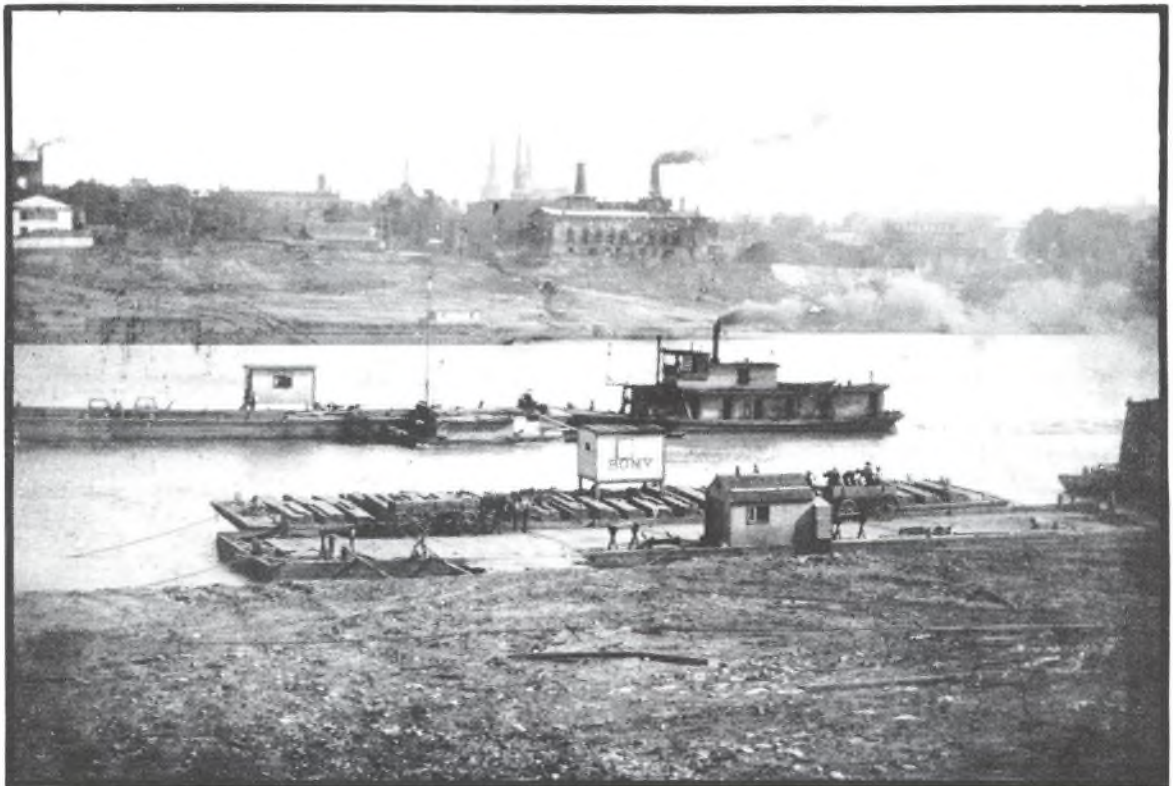

Long view of the Covington factory looking south from Cincinnati.  
Building is at top center.  
C. 1880

(Courtesy of the Cincinnati Historical Society)



From about 1873 through 1878, the Hemingray Glass Company maintained a branch office in St. Louis, Missouri, managed by James Foley. St. Louis is about 350 miles west and slightly south of Covington on the Mississippi River. The address shown on the ad below was located just north of the present-day arch, just about two blocks from the river. Today nothing remains of the original Hemingray building. This was no doubt just a salesroom and warehouse; no products were made there. Time did not allow me to look for photos of that area in the 1870s, so I will leave that to a future Hemingray historian.

The Covington years saw many innovations and changes for the company. In 1871 Robert Hemingray received a patent covering the process of forming the cavity in insulators. (This and other patents

**SAINT LOUIS BRANCH**  
**HEMINGRAY GLASS CO.**

*JAMES L. FOLEY, Manager.*

*No. 219 North Second Street, ST. LOUIS,*

**MANUFACTURERS OF**

**FLINT, GREEN AND BLACK GLASS,**

*FRUIT JARS, CHIMNEYS, LAMPS.*

Demijohns, Minerals, Fish Globes, Ring Jars,  
Shades, Lanterns, Glass Labels, Specie and Squat  
Jars, Confectioners' Jars, Ale, Porter, Brandy  
and Schnapp Bottles, Druggists' Shop  
Furniture, Telegraph and Light-  
ning Rod Insulators.

☞ SPECIAL ATTENTION GIVEN TO PRIVATE MOLDS.

Company ad from St. Louis, MO, branch.

Gould's St. Louis Business Directory

1873

(Courtesy of the St. Louis Public Library  
and Glenn Drummond)



Dot shows approximate location of Hemingray branch office.  
 Looking east.  
 St. Louis, MO  
 30 Jul 1997

R. HEMINGRAY, President, R. EVANS, Vice-President. E. D. SWASEY, Sec'y and Treas.

## Hemingray Glass Co.,

MANUFACTURERS OF

### Lamp Chimneys, & Table Ware,

Sand Blast, Cut, Gas & Kerosene Globes and Shades,  
 Opal Globes and Cone Shades for Gas and Kerosene; Smoke  
 Bells; Specie, Squat and Ring Jars; Bar Bottles, Syrup  
 Bottles, Jelly Tumblers, Aquariums and Fish Globes;  
**Druggists' Shop Furniture and Show Jars.**  
 Cake-Covers, Sample-Bottles, Flint and Green Flasks,  
 Demijohns, Brandy, Wine, Mineral, and Ale Bottles.

The Celebrated "Royal" Improved Screw-Top Porcelain-Lined  
 Self-sealing Fruit Jars. Wire-Top Fruit Jars for Wax.

**Salesroom, 68 Walnut Street,**

Factories cor. Second & Madison Sts,  
 COVINGTON, Ky.

**CINCINNATI, Ohio.**

AGENTS: { JOHN A. DOBSON & CO., 31 South Charles Street, Baltimore.  
 { BOTSFORD & WHIPPLE, 63 Park Place, New York.

Company ad.

Crockery & Glass Journal

15 Jun 1876

(Courtesy of Glenn Drummond and Bob Stahr)



can be found in "The 'Catch-all' Room" beginning on page 398.) Then came Samuel Oakman's patents for both the petticoat and the beehive design in 1883 and 1884 respectively. (This paved the way for the production of the best-looking insulator anywhere...the H. G. CO. PETTICOAT beehive!) But those same years brought two other events that would also affect Hemingray...floods!

Although there would be no more name changes, the company had one more move coming up. Being as close to the river as they were had its good points but it also had its drawbacks. Such easy access to the water made the loading and unloading of products and supplies fairly convenient, but this convenience was outweighed by the reality that rivers sometimes flood. And this is exactly what happened two years in a row. In both 1883 and 1884 the Ohio River at Covington rose over 14 feet above flood stage, which was more than six feet above the company's foundations. The damage to the Hemingray facility caused by those floods prompted company officials to look for higher ground. And they found it approximately 100 miles to the northwest, in Muncie, Indiana.

Much damage was done to all businesses along the river, including Hemingray. These disasters came around the same time that Muncie was widely advertising newly discovered and plentiful natural gas deposits in their area. The city was offering cheap and easily obtainable fuel, and promoted its location with such slogans as "Magic Muncie" and "Muncie Offers More". The recent memories of flood waters, and the lure of inexpensive fuel prompted the Hemingray Glass Company to move to Muncie.

## **COVINGTON, KENTUCKY**

### **~ NOW ~**

The Covington plant was listed for the last time in the city directory for 1918-1919. The buildings at the site were added to during the years after Hemingray sold the property, around 1919. There were many tenants at the site before Fries & Son occupied the buildings in 1922. Fries & Son was a steel construction and engineering company making jail and prison equipment. (Their name was still on the back of the building when I was there in 1976.) They were there until the 1960s, when Escue Pontiac (later Datsun) moved from 17th and Madison and bought the old Hemingray property. (The "R. Hemingray" building with the two chimneys in the 1800s photos was torn down between about 1945 and 1950 to make way for the flood wall that is there now.) In 1980 the levee that protected Covington ran across the grounds of the old plant. (An old company letterhead dated 1885 shows the 2nd and Madison building as having four stories, but it had only two when I was there. So somehow in the history of the building two stories were lost.)

During our visit in 1976, we walked around the buildings, which included the offices of the Hemingrays, and picked up slag glass





NW corner of 2nd and Madison Sts.,  
looking northwest.  
(Location B on map on next page)  
23 Aug 1976

out in back by the levee. We took a few photos, but didn't ask to go inside the buildings.

Escue had used the Hemingray buildings for car repairs until it remodeled the west end corner for a Datsun dealership. They used the rest of the buildings for car repair and servicing and painting cars. (Thus the wild paint job on the building seen in subsequent photos.) They had a used car lot at 2nd and Madison, northeast corner, which was closed in early 1981 due to slow business. The Pontiac dealership was given up that same year.

In November 1980 an announcement was made in The Kentucky Post that this site was proposed for demolition to make way for a riverfront development project. But before the razing could take place, the buildings at 2nd and Madison were burned out on the night of 2 November 1981. With them went the building erected in 1881 by Hemingray; it had stood for exactly 100 years. The Escue fire was caused by arson, but it was never found out who was responsible.

I am very grateful to Franklin Jaquish, a Covington resident, who was on the scene the day after the fire, and captured the dramatic photos which follow. Workers started to tear down the building the very day after the fire to get the office files and safe out. The safe was on the second floor above the vault, located on the first floor. It was the original Hemingray safe and vault in the 1881 building. The safe was surrounded by bricks top, sides, and bottom. It was not hurt at all by the fire, and was set up on the ground where the photos were taken. Contents inside including quite a bit of cash were untouched by the fire.

The walls of the building were cracked and bulging so badly that they were dangerous. The fire exposed old walls inside with windows and doors that had been bricked up. The Hemingray offices were at 2nd and Madison at the east end of the building. (In the photo above, they are the four bricked-up windows left of the large open door.) Off of 2nd Street the old office corner was burned out pretty well, but didn't blow up. The 2nd Street side of the building



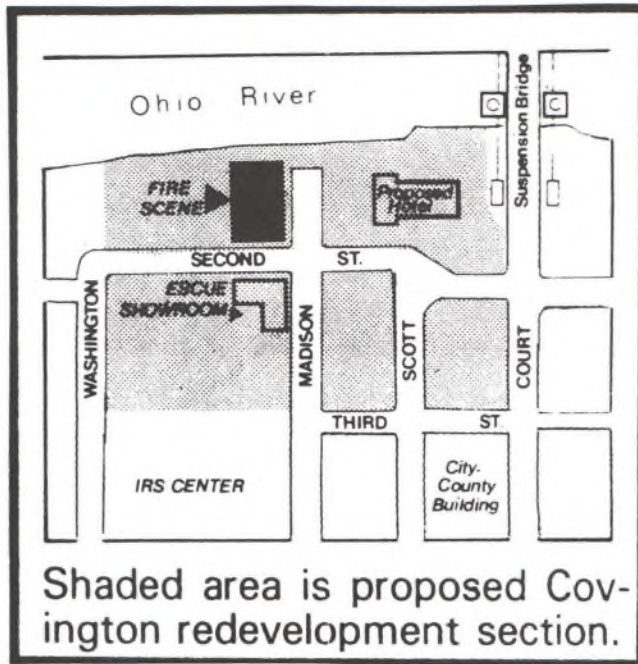

Shaded area is proposed Covington redevelopment section.

Map showing proposed redevelopment section, Covington.

The Kentucky Post

3 Nov 1981

(Courtesy of Franklin Jaquish)

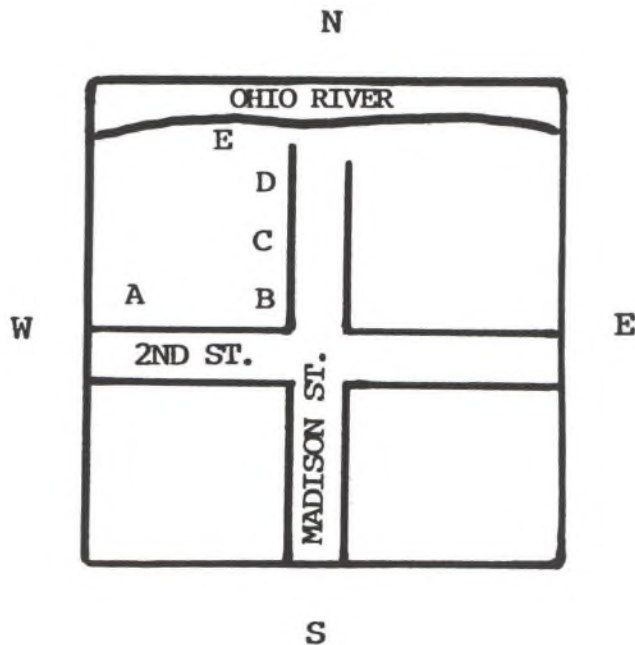

Reference map of Covington factory site showing locations mentioned for photos on pages 110, 114, 115, and 116.



Covington site the day after the fire,  
looking west.  
3 Nov 1981  
(Courtesy of Franklin Jaquish)

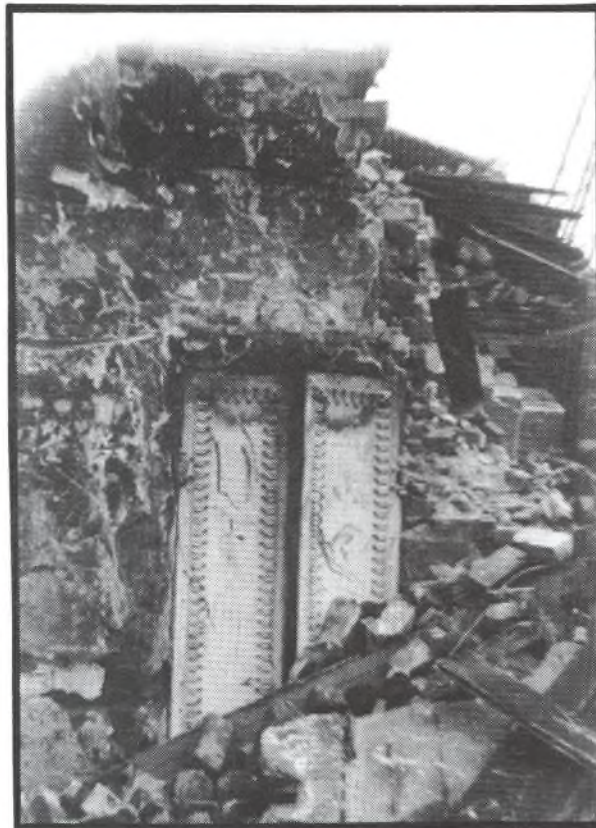

After the fire, the vault on the 1st floor,  
facing 2nd and Madison Sts. A small hallway was  
between the vault and the outside wall. Stairs  
went up to the right to the 2nd floor.  
3 Nov 1981  
(Courtesy of Franklin Jaquish)



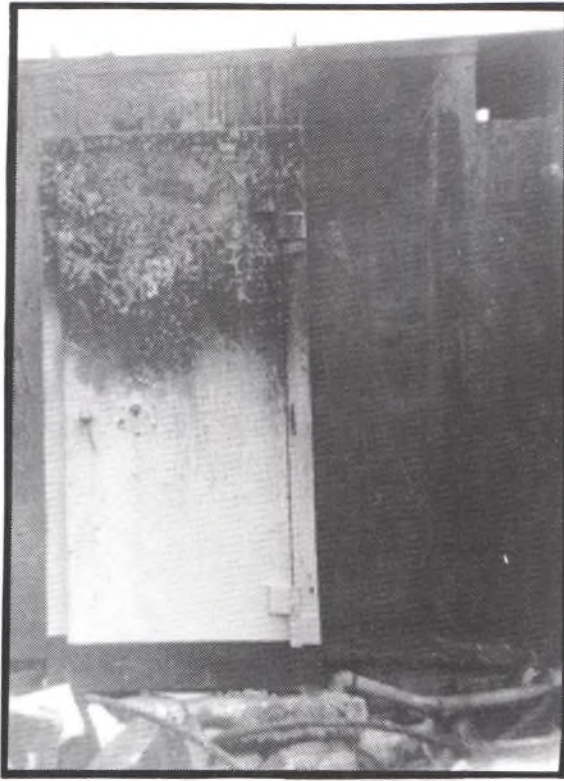

After the fire, the old Hemingray safe  
from the 2nd floor. Note fire marks on top of door.  
3 Nov 1981  
(Courtesy of Franklin Jaquish)

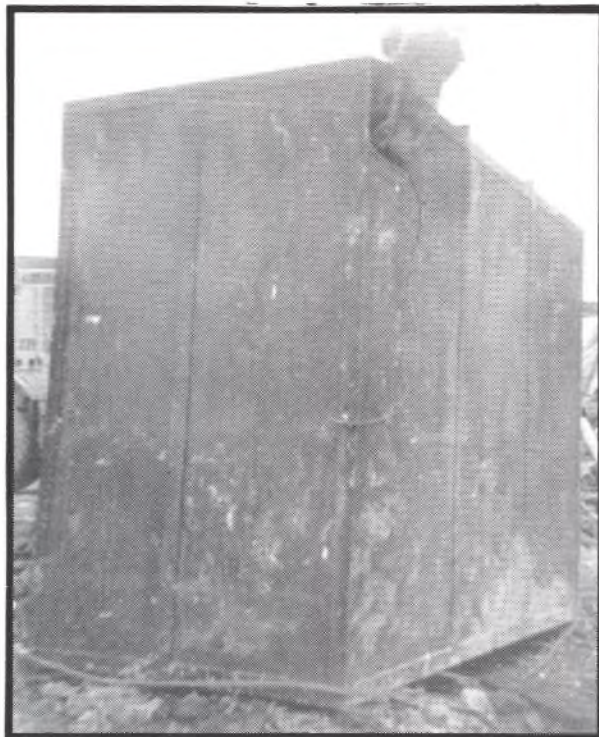

Back of the safe.  
3 Nov 1981  
(Courtesy of Franklin Jaquish)



NW corner of 2nd and Madison Sts.,  
looking north to Ohio river.  
(Xs show Hemingray offices)  
(Locations B, C, and D on map)  
C. 1980  
(Courtesy of Franklin Jaquish)



Same view after fire.  
Nov 1981  
(Courtesy of Franklin Jaquish)



Same view.  
Sep 1996  
(Courtesy of Franklin Jaquish)





NW corner of 2nd and Madison Sts.,  
looking west down 2nd Street.  
(Locations B and A on map)  
23 Aug 1976



Same view after fire.  
Nov 1981  
(Courtesy of Franklin Jaquish)



Same view.  
Sep 1996  
(Courtesy of Franklin Jaquish)

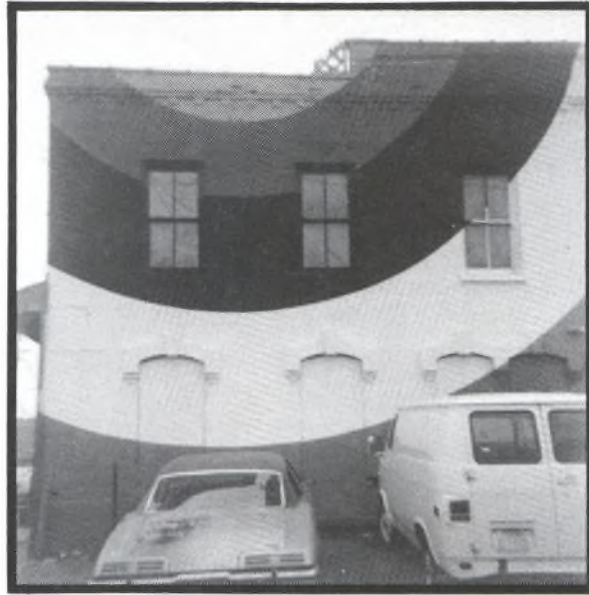

Close-up of Hemingray offices (1st floor)  
on Madison St., looking west.  
(Location B on map)  
Nov 1980  
(Courtesy of Franklin Jaquish)



Behind building between floodwall,  
looking west.  
(Location D on map)  
23 Aug 1976



# Excavation along river yields history

By T. C. Brown  
Kentucky Post Staff Writer

The past is surfacing along the Covington riverfront.

Excavators have recovered almost 300 bags of artifacts, including the remains of a glass factory, pottery plant and steel mill, researchers say.

The digging is part of the RiverCentre project, a complex of offices, a hotel and theme park planned along the Ohio.

But continued work at the bank could cost Covington \$150,000.

Economic Development Director Tom Florini said no final cost has been determined, but he would "not be surprised if the final figure approached \$150,000."

City Finance Director Greg Engelman said payment for the digging probably will come from a \$16 million bond issue the city intends to float for the entire development project.

Florini said the digging was initiated because of the 1966 Historical Preservation Act. He said the excavation is required whenever federal money is used toward a project like Rivercentre. An \$8.1 million grant from the U.S. Department of Housing and Urban Development will help finance the \$70 million development along the river.

Florini said tests and archaeological surveys are nearly complete. Consultants have made some recommendations to the city and state government about which resources may be destroyed and what research questions must be addressed.

Bob Genheimer, the city's consultant, said the finds have been historically significant. Articles have been recovered from a previously undocumented pottery plant and the other evidence tells archaeologists more about Covington's past. That evidence would have been destroyed if not for the excavation.

Researchers have uncovered glass objects and the foundation of the Heminggray Glass Factory dating from 1853, articles from an 1830 steel mill that made nails, and artifacts from a pottery plant that operated in the 1830s to 1840s.

Items recovered include insulators, bottles with markings, paintings and etchings, flasks, and a "rare find" of a cast-iron bottle mold. Workers also have uncovered a number of privies with more domestic items.

Genheimer said he has recommended more excavation, but said researchers will work within the city's demolition schedule.

Recovered items will be turned over to the Behringer-Crawford Museum.

Article about archaeological dig.  
The Kentucky Post  
13 Jun 1986  
(Courtesy of Franklin Jaquish)

stood up all right, but was burned up inside.

In 1986 an archaeological dig was done along the riverfront which included the old Hemingray property. A two-volume report was done on this project. According to Archaeological Testing, Evaluation, and Final Mitigation Excavations at Covington's Riverfront Redevelopment Phase 2 Site, Kenton County, Kentucky, by Robert A. Genheimer (1987), this dig revealed privies, cisterns, company building foundations, furnace features, and decorating ovens used to do fancy finish work on lamps, etc., and many artifacts including insulators and pottery shards.

By May 1992 the Hemingray factory site at 2nd and Madison was a parking lot with hedges, and a hill of grass around the edges with some young trees. Nearby there is a big office tower with a couple of floors of parking on the bottom and 14 floors above, a couple on ground level for shops, and a bank, businesses, and offices on up to the 14th floor. There's a businessman's club on the top floor.

## Beam tops off RiverCenter II

By Cliff Peale  
Post staff reporter

While placing the last steel beam in place for the RiverCenter II tower on the Covington riverfront Friday afternoon, officials at Corporex Cos. Inc. promised more.

They hope to have tenants in the 15-story tower this year.

After that, they will start serious work on Madison Place, a hotel, office and condominium complex just west of the Embassy Suites hotel.

First unveiled in 1995, Madison Place would include a 325-room luxury hotel, eight floors of office space, an extended-stay hotel and 12 luxury condominiums.

"There is no looking back," said Tom Banta, senior vice president of development at Corporex. "We know now we did the right thing."

About 40 percent of the 240,000 square feet in the new

tower is leased, and Corporex is close to agreements with tenants to fill several more floors, Banta said. He called RiverCenter, which includes the Embassy Suites and the 18-story RiverCenter I, "one of the most successful mixed-use developments in the country."

The developer has plans for a parking garage, a park and a new Kenton County courthouse in the surrounding blocks.

Real-estate brokers have been touting the building to local companies and have bought several prospects to Corporex, Banta said.

Last year, Jacor Communications Inc. moved from downtown Cincinnati to RiverCenter I, and Omnicare Inc. is negotiating to move its Cincinnati headquarters to the second tower.

Embassy Suites has built a hotel to the left of the tower to Madison Avenue, on the northeast corner of 2nd and Madison. Old 2nd Street has been renamed "River Center Boulevard" from the suspension bridge west. As of this writing there is a parking structure on the old factory site on the northwest corner of 2nd and Madison. A hotel, Madison Place, will soon be built on top of the parking structure, at which time a better facing will be put on.

On the southeast corner of 2nd and Madison will be a convention center. (What a place for a national insulator show!) This whole area will be a business center. The Ohio River behind the old Hemingray property (where I found the slag glass) now has several big steam riverboats docked there, containing saloons, dance halls, restaurants, and night clubs, with walkways to and from River Center. So now this area, which was a factory area

Article about Madison Place complex  
at Covington factory site.

The Kentucky Post

7 Mar 1997

(Courtesy of Franklin Jaquish)





River Center dock on the Ohio River, at the foot  
of Madison St., looking north.  
Covington, KY  
May 1992  
(Courtesy of Franklin Jaquish)



River Center Drive on the Covington side  
of the Ohio River looking west. (Arrow shows  
approximate location of Hemingray riverfront property.)  
May 1992  
(Courtesy of Franklin Jaquish)

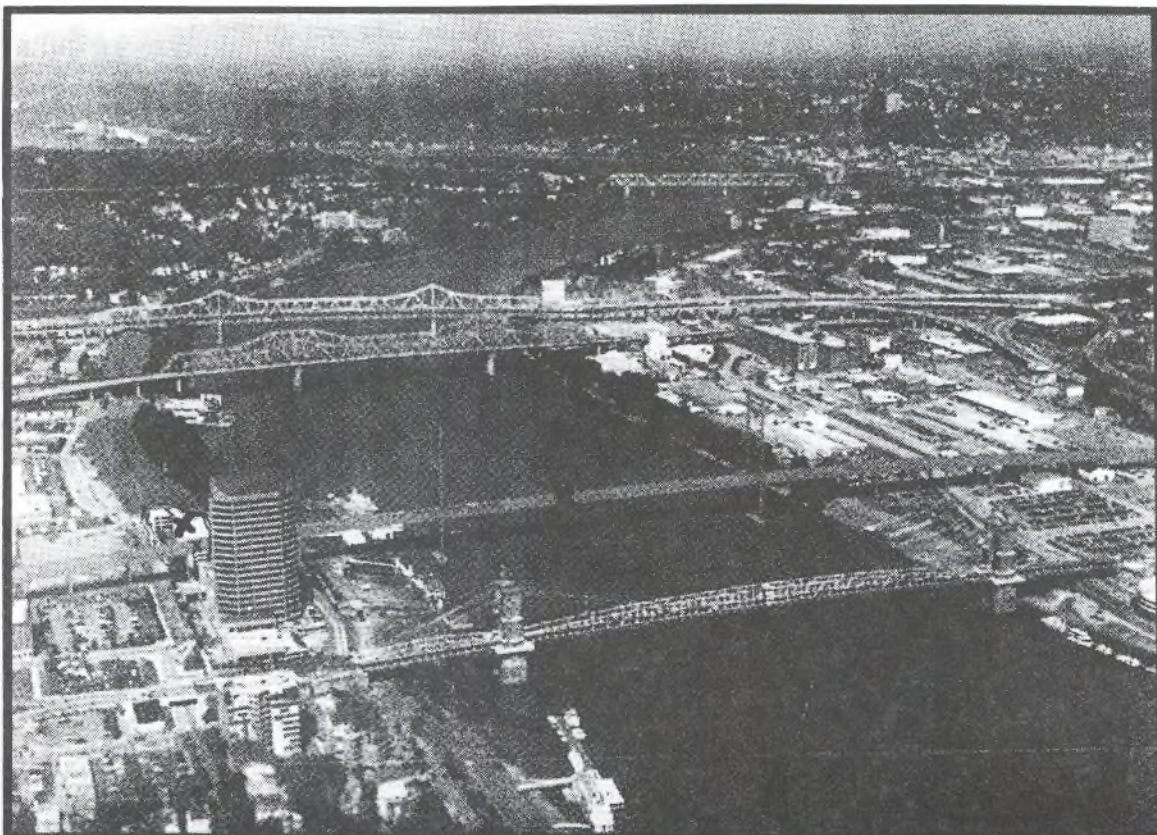

Bird's-eye view of the Ohio River looking west.  
(Bridge in center marked with an X is proposed. The small X  
left of tall building at left marks site of the  
Hemingray Glass Co., now a parking structure.)

The Cincinnati Post

13 Sep 1996

(Courtesy of Franklin Jaquish)

*The accompanying photo shows Covington on the left and Cincinnati on the right. The white area just behind the tall building on the left is the parking structure that occupies the old Hemingray Glass Company site. The bridge seen crossing the Ohio River behind the tall building is an artist's rendering of a proposed bridge to be built for light rail cars or buses. People could use them for going to work, or for visiting Covington and Cincinnati areas. The rail line would also serve the Greater Cincinnati Airport in Boone County, Kentucky, about 20 miles outside of Covington. This would eliminate the need to take a car or taxi to the airport. The bridge, if built, would go from Madison Avenue in Covington to Race street in Cincinnati. (A note of interest; the suspension bridge seen in the foreground served as a scale model for the Brooklyn Bridge.)*



for over 100 years, giving poor and middle class people a living, is now going to be a business and pleasure area for the better class and well-to-do people of northern Kentucky and Cincinnati.

## **MUNCIE, INDIANA**

### **~ THEN ~**

The next 43 years, the last years for Hemingray, were spent at Muncie, Indiana. In 1888 the Hemingray Glass Company purchased a site on the southeast side of Muncie, on the east side of South Macedonia Avenue at 9th Street, with construction beginning immediately. By 1890 the plant was finished to the point where most of the production could be moved there from Covington. But on 18 June 1892, just when the factory had become well established, the plant was partially destroyed by fire, causing temporary interruption in production. It is possible that this fire also destroyed many of the company's records, which would have been those from both the Cincinnati and Covington era. Also burned was the nearby Charles H. Over window glassworks factory. Ralph Hemingray was in Covington when Muncie burned but returned immediately. Covington was revitalized and took over for a while. Muncie was promptly rebuilt, however, and resumed operation in better condition than before and with a minimum of delay.

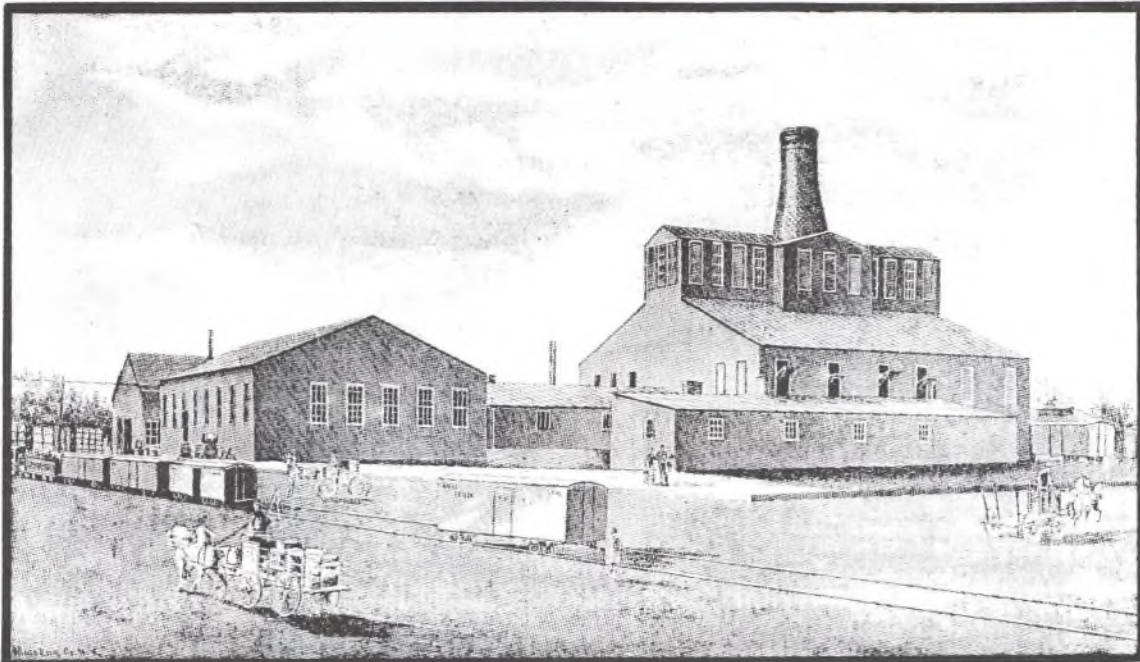

The Muncie factory.  
This is the factory that burned in 1892.  
Muncie, Past, Present, Future (1893),  
by Bob Cunningham and Bob Stephenson, 1985  
(Courtesy of Rosella Cartwright, Bob Stahr, and  
the Muncie Public Library, Indiana Collection)

# HEMINGRAY GLASS COMPANY

(INCORPORATED 1870)

COVINGTON, KENTUCKY

*GLASS INSULATORS*  
of  
*ALL KINDS for ALL SERVICES*

*"See the Teats on the Petticoats"*



Company business card.

Jun 1913

(Courtesy of Ray Klingensmith)

In 1893 the "drip point" patent was awarded to Ralph Hemingray and James C. Gill. Gill was a moldmaker for Hemingray. These drip points, located on the base of the insulator, eventually became a Hemingray trademark. (See "The 'Catch-all' Room" page 395 for more information on drip points.)

Covington was kept as a warehouse and sales office until 1919, but the main headquarters and factory were at Muncie. Covington and Muncie may have operated simultaneously for a two-year period between 1888 and 1890. But newspaper accounts indicate that as soon as the Muncie facilities were completed, labor and production were moved from Covington, with the exception of the tin shop which was moved later. (The tin shop made tops for candy jars and other glassware, and sidelamps of tin, probably the shield between the lamp globe and the wall.) If the two factories were operated simultaneously, it didn't go on for very long, for running the two factories would have been costly, considering the huge costs of running all of the furnaces and labor costs for the hundreds of employees needed for the various departments at both places. Hemingray did lease portions of the buildings at Covington until they sold it. An interesting note; the Covington site was reactivated by Colonel H. H. Hardy in September 1898 to produce an incandescent lamp he invented. Called the "Covington Glass Company", it only lasted until that November when it was sold to satisfy creditors. It has not been determined if glass production ever occurred under the Covington Glass Company.

The Muncie factory site covered a much larger area than had Covington, covering approximately 12 acres. (Under Owens-Illinois





## 1848 THE STORY OF HEMINGRAY SCREW GLASS INSULATORS—1904.

Among the manufacturers of screw glass insulators in the United States, the Hemingray Glass Company of Covington, Kentucky, stands as a pioneer, whose goods for scores of years have successfully stood the most severe tests, and at the present time are in use in all parts of the United States. When it is taken into consideration that the Hemingray Company was established in 1848—more than half a century ago, beginning the manufacture of glass insulators at that time—it can be readily understood why the product of this concern is so well known throughout the country. In the fullest sense have its insulators been "time-tried and fire-tested."

In 1870 the business was incorporated, since which time it has increased its output each year and made marked improvements in the class of goods manufactured. At the present time the claim is made that the Hemingray Glass Company is not alone the largest establishment of its kind in the world, but that its yearly output and sales are more than those of all the other insulator manufacturing industries combined. It manufactures annually many millions of insulators, all of which find a ready market. The factory at Muncie, Indiana, is kept running day and night, but even with the plant working to its outside limit, the company reports that it is behind in its orders. The offices of the concern, at Covington, Kentucky, are a busy hive of industry.



The Hemingray Company manufactures more than thirty different types of high potential insulators, all with "patent drip petticoats." The points or teats on the lower rim of the "petticoat" attract the water on the outer and inner surfaces of the insulator into drops. The drops from these points fall on the cross-arm, thereby preventing the moisture from creeping upon the insulator, and thence to the pin. It is claimed that

they have given the best satisfaction of any insulator ever designed for the purpose. The company also makes several varieties of insulating or break knobs, electric light globes and battery jars.

It is the proud claim of the Hemingray Company that to the superiority of its insulators, more than any other agency, is due the marvelous success of high voltage power transmission. The reasons it advances for this cover all the

cardinal points in the case. Primarily, perfection of manufacture leads the list, and is given the credit for being the chief feature in winning success in the insulator market. Perfect design, uniformity of quality, and mechanical and electrical strength are also named as leading points of merit in its goods. It has been the one aim and constant study of the Hemingray Company not only to improve its insulators wherever possible, but also to obtain the highest degree of electrical and mechanical perfection in the construction of the same.

One of the leading insulators manufactured by this company is the "Provo"—its standard type for voltages of from 10,000 to 50,000. It is furnished in several types. The "Provo" insulators were named after Provo City, Utah, where the main generating station and offices of the Utah Department of The Telluride Power Company are located, and where the insulators were first used.

Another insulator of still greater voltage carrying capacity is the Gerry 55,000-volt type, known also as the 9-inch Muncie type. This insulator is used on the high voltage transmission between Canyon Ferry and Butte, Montana. It is all glass, non-cemented, and it is claimed for it that it has carried as high as 57,000 volts.

A high-tension insulator made by the Hemingray Company recently stood a test of 120,000 volts without a breakdown.

Speaking of its insulators in a general way the company in its catalogue says:

Our experience in the manufacture of insulators dates from their earliest use. We have a very extensive equipment for this work, and our factories are advantageously located in the natural gas district. High voltage insulators are given especial attention both as to the quality of glass, and the process and length of annealing.

Not the least important is the careful selecting and packing of high voltage insulators. Many times insulators are delivered to the customer which were never fit for use, or arrive in a thoroughly unfit condition. We have been many times complimented on the even grade of our high voltage insulators and the apparent care that was exercised in the packing and shipment.

We will be pleased to furnish on request, full information regarding other manufacturers' statements of measurements on our insulators.

Nearly 100 big electric railway, power and lighting companies throughout the United States use the high potential insulators manufactured by the Hemingray concern, besides scores of smaller companies. The four highest voltage plants on which the "Provo" insulators are used are: The Telluride Power Company, The Logan Power Company, The Power Company and The Kalamazoo Valley Electric Company, all operating at 40,000 volts or over.

Catalogues, price lists and any other information desired will be furnished on application.

Article about Hemingray.

Telephony  
May 1904

(Courtesy of Mike Sovereign,  
Elton Gish, and Bob Stahr)



ownership the property increased in size. According to a "for sale" sign up at Muncie in 1981, the plant consisted then of 282,000 square feet, with 11,232 square feet of office space. There were 21.6 acres, and industrial rail.)

Muncie started out with just one furnace built in 1888, later called "A" furnace after "B" furnace was added a few years later. "B" furnace was larger than the first one, but both were considerable in size. By 1911 there were at least four furnaces visible on the Sanborn fire insurance maps. The furnaces were kept running around the clock, seven days a week. They were only shut down for two months in the summer, at which time inspections and repairs were made. (More about the Muncie plant can be found in Part III, and more on the furnaces can be found in "The 'Catch-all' Room" page 410.)

## HEMINGRAY

*Particular description of goods.*—Electric, Telegraph, Telephone, Cable, Street-Railway, and Floor Insulators and Break-Knobs of Glass.

Company ad.

Official Gazette  
29 Mar 1910

(Courtesy of Glenn Drummond)

Business for Hemingray went pretty well until the early 1930s. The History of Delaware County, Indiana, by Frank D. Haimbaugh (1924), lists the Hemingray Glass Company as employing about 500 persons at maximum production, and says, "...it's products are known wherever electric wire construction is known." The 1920s saw many changes for the company. The plant's operations became more mechanized and modern, and thus fewer employees were needed, so other items besides insulators had to be added to Hemingray's line in order to keep everyone employed. In the mid-1920s the production of glass bottles was introduced, and according to reports of the day, their bottle production was unusually successful. Early in 1927 the office building burned down, and some company records were lost. Things were not going well by the early 1930s due to the Great Depression. The repeal of prohibition in 1933, causing a higher demand for glass bottles, did not come in time for Hemingray, since negotiations were already under way with Owens-Illinois. Although the company had survived many other upsets, the Depression was a major setback. That, along with accusations of possible mismanagement, brought the downfall of the Hemingray Glass Company. It was sold to Owens-Illinois in 1933. (Newspaper articles on these subjects can be found in "The News Room" beginning on page 252.)



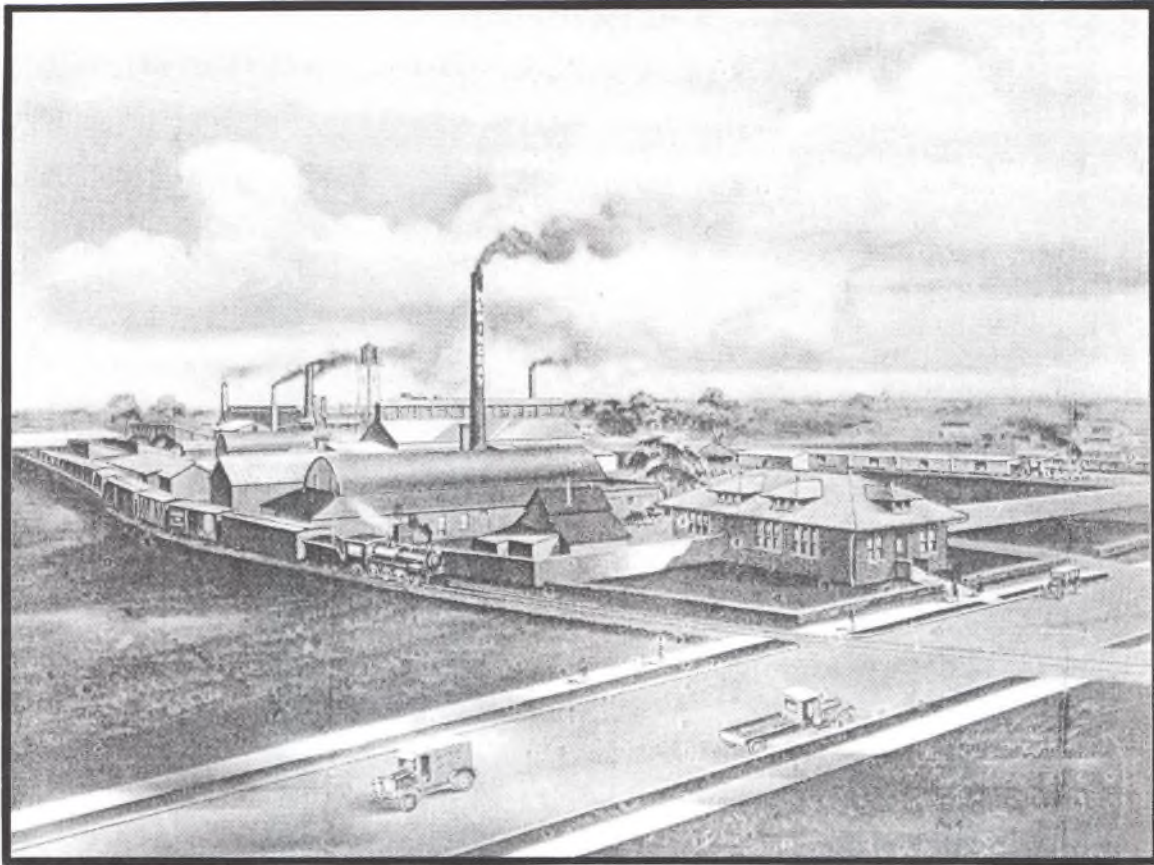

The Muncie factory.  
Muncie Indiana: Illustrating Some of Its Industries,  
by the Dynamo Club  
1939

(Courtesy of Ruth Crawford, Rosella Cartwright,  
the Delaware Co. Historical Society, and  
the Muncie Public Library)

Although this drawing appeared in a 1939 publication, it actually shows the Muncie factory area as it appeared in the mid-1920s. The office building in the foreground is the one that burned in 1927. (More details on page 132.) The street in front is South Macedonia Avenue, and this scene is looking east southeast. In comparing this drawing to the photo on page 129, it is apparent that Hemingray added more office space to the rear of the building, as there are now two dormers on the north side of the roof instead of one, and there is an additional window at the rear. (The fence intersects the building at about the point where it ended previously.)

During the Owens-Illinois era, the property to the left was purchased, and warehouses were added, as was another office building and various outbuildings and storage tanks.

# For 79 Years Hemingrays Have Been Manufacturing Glass Products.



No. 1—No. 2 Factory.  
No. 2—New Office Building.  
No. 3—No. 1 Factory.

No. 4—Insulators Coming From  
Annealing Ovens.  
No. 5—Part of Surplus Stock  
of Insulators.

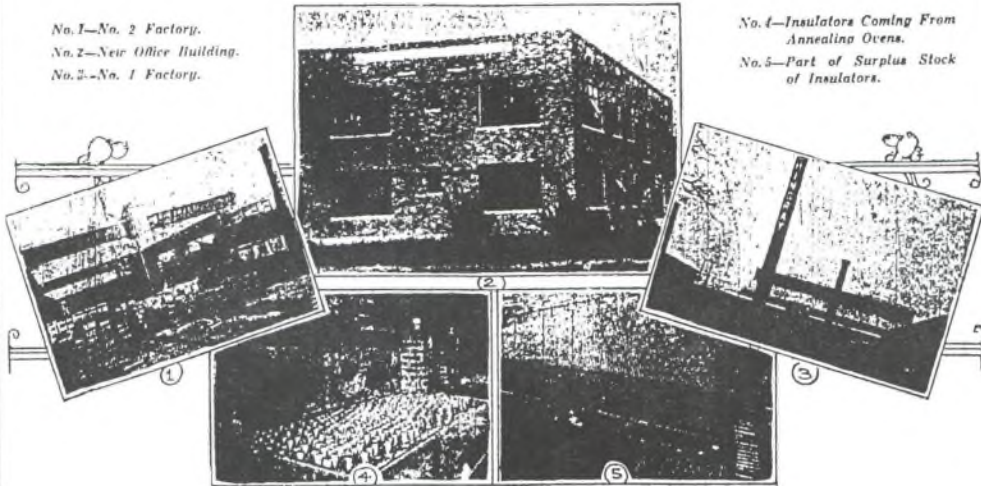

FOR 79 years, the Hemingray Glass Company has been making glass products.

For 50 years, it has been making glass insulators for telephone, telegraph and power transmission lines.

Hemingray insulators can be found in all parts of the civilized world.

From a small beginning, backed by a determination to manufacture a quality product, plus a service to its customers in engineering problems and scientific research to be always ready to meet the new developments in electrical transmission, Hemingray's have grown through the years of its existence to one of the largest insulator manufacturing plants in the world with a steady and increasing market for its products.

## Hemingray Glass Company

Established 1848.

Muncie, Indiana.

Incorporated 1870.

Company ad.  
The Muncie Star  
25 Sep 1927

(Courtesy of Rosella Cartwright,  
the Muncie Public Library, and Bob Stahr)



1848

1927

## Keeping Pace With Progress for 79 Years

*James K. Polk was president of the U. S. when  
Hemingray began manufacturing glass products*

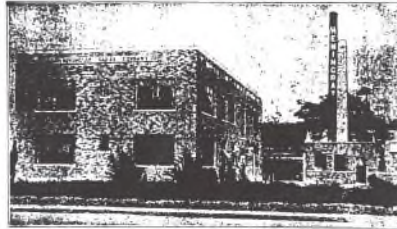

Three years ago, adding to our regular line of Glass Insulators for Telephone, Telegraph powers and Light Companies, we resumed production of one of our earlier lines-BOTTLES. Today, at almost any dispensary of beverages, you are possibly served from one of our bottles. Our quality has secured for us the larger customers in the beverage field. Bottles for home use can be secured from our local dealer.

*Quality and Service*

# Hemingray Glass Company

MACEDONIA AVENUE

PHONE 7

Company ad.

The Muncie Evening Press

27 Sep 1927

(Courtesy of Rosella Cartwright and  
the Muncie Public Library)

A word or two in addition about the ads seen on these two pages; the one on this page measured  $17\frac{1}{4}$ " by  $11\frac{1}{2}$ ", and was sent in four pieces. I restored it by putting the pieces together with tape. The edges didn't always line up exactly, so I had to fill in the spaces. The ad on the previous page was about twice as large as shown. Because both ads were heavily lined and smudged, a lot of Liquid Paper was used, which was especially tough to use around the small words. But the end result was well worth the effort. Both ads are beautiful. I thank Rosella Cartwright who first found them both for me. (Note the phone number on the ad on this page...7!)

## OFFICE BURNS, LOSS IS \$10,000

### Recent Records of Hemingray Glass Company Not Damaged in Fire.

More than \$10,000 damage resulted from fire in the office building of the Hemingray Glass Manufacturing Company, near Macedonia avenue and Ninth streets, at 5:25 o'clock yesterday morning. The company established temporary offices in the rooms recently occupied by the Muncie Savings and Loan Company at High and Adams streets. The loss was covered by insurance.

Though the interior of the building was badly damaged, the building proper was saved. Recent records of the glass company were stored in metal cabinets and were not damaged but older files together with those of the 326th Infantry Brigade of the Reserve Corps were stored on the third floor and burned. Firemen were endangered by exploding ammunition which had been stored in the army office.

#### Started in Basement.

Charles Brown, 800 South Vine street, the factory watchman, said he was in the building and fired a boiler in the basement, which is believed to have started the fire, about 5 o'clock. The blaze was discovered a few minutes later in the basement. The plant firemen tried to fight the blaze for a few minutes then called the city firemen.

From the basement the fire burned upwards through partitions to the attic where it "mushroomed" against a slate roof which threw the blaze down on top of the hose crews battling inside the building. Fire was leaping through every room in the building when the trucks arrived. Four lines of hose were used.

Two truck drivers were arrested by the police for running over fire hose in use at the blaze. They are Thurwald Simmes, of Muncie, and Fred Wiggins, 111 West Heymour street. They will be arraigned in City Court today on a violation of the city ordinance.

Article about fire.

The Muncie Star

22 Feb 1927

(Courtesy of Rosella Cartwright)



*This is an enlargement of a photo sent to me by Elton Gish. It comes from a 1907 issue of The Electrical Review. (A reproduction at actual size can be seen on the following page, along with the accompanying article. I've also included personal comments about the photo and the three men on the porch.)*

*Elton was kind enough to trust me with his original copy of this wonderful photo, which came right out of the magazine itself. (Bob Stahr had a copy which he was willing to send, so he gets credit also.) I just can't thank Elton enough for trusting me with this beautiful piece of Hemingray history.*

*Shown below also is an enlargement of the three men. If anyone can positively identify any or all of them, please let me know.*

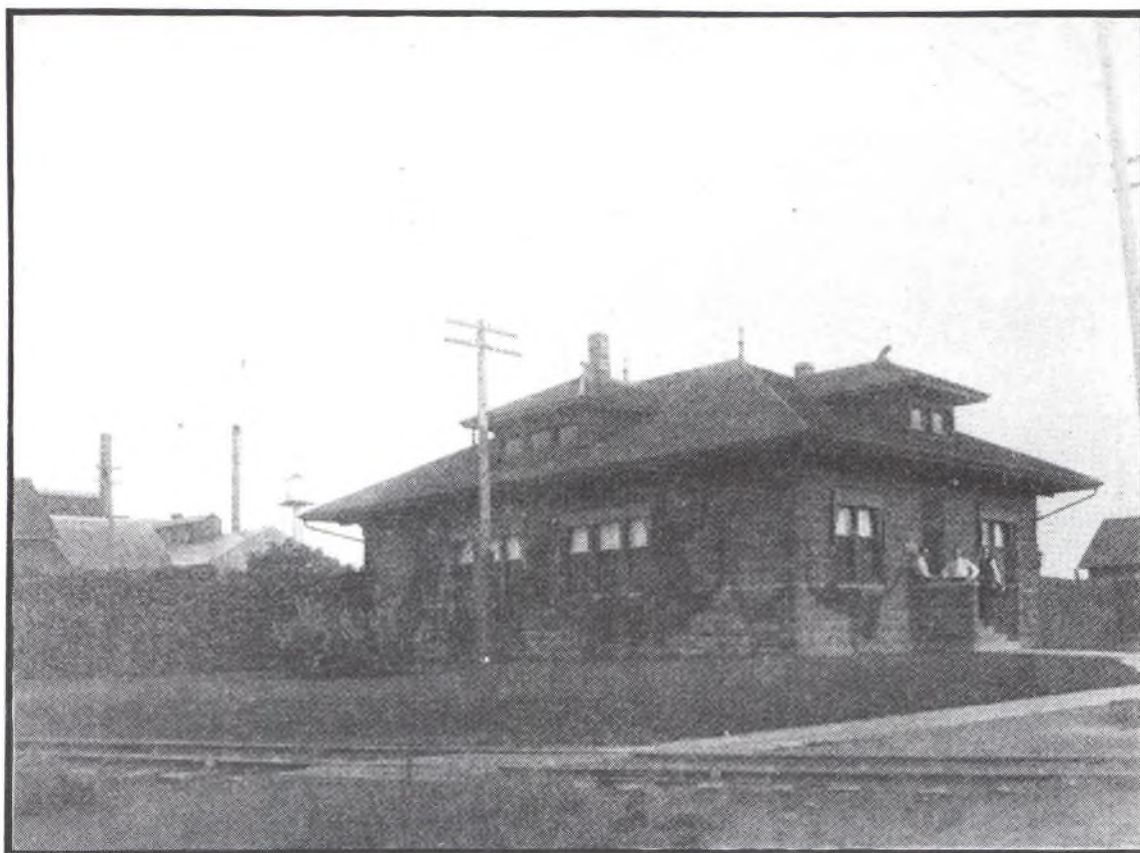

## The Hemingray Glass Company.

The accompanying illustration shows the office building at the works of the Hemingray Glass Company at Muncie,

Office building at Muncie.  
The Electrical Review  
30 Nov 1907  
(Courtesy of Elton Gish and Bob Stahr)



HEMINGRAY GLASS COMPANY, MUNCIE, IND.

Ind. The plant at Muncie covers nine acres of ground, the Hemingray Glass Company being the largest manufacturer of glass insulators in the world. The capacity of the plant is 50,000,000 a year. The firm was established in 1848, at Covington, Ky., and the company started to move its plant from Covington to Muncie in 1888. The plant at Muncie was gradually built up until it was of a sufficient size to abandon the plant at Covington. The company carries a stock sufficient to supply demands and make immediate shipments. The main office is at Covington, Ky.

### NOTES ABOUT THE PHOTO

*This office building was built in either 1904 or 1905, so I believe that the photo was taken around 1906, as the landscaping is in place. Who are the three men on the porch? It is almost impossible to tell because the photo was taken from so far away. But an educated guess would be that from left to right is Daniel Hemingray, Ralph Hemingray, and Bradford Shinkle, secretary/treasurer, president, and vice president respectively. Perhaps the original photo will show up one day with the names written on the back.*





Glass block office building fronting Macedonia Ave.,  
with driveway and entrance gate in foreground.  
Looking southeast.  
Built C. 1934  
Muncie, IN  
Jun 1996  
(Courtesy of Bob Stahr)

#### OWENS-ILLINOIS BUILDS ADDITIONAL OFFICE BUILDING

The glass block office building seen in the above photo first appeared on a Sanborn Fire Insurance map dated 1934. It was most likely built after O-I bought Hemingray in mid-1933, and prior to the publication of this map in late 1934. Employees and visitors would enter the glass factory grounds by checking in at the semi-circular guardhouse portion of the building seen at left center in the photo.

The original windows in the building were most likely steel frames with glass panes like those seen on the guardhouse. After O-I began production of glass building block in 1935, these panes were probably replaced with glass block like those seen in the photo. This could have been done as a means of promoting sales of the block to architects and building owners. This building is of obvious Art Deco design, and the use of the glass block makes it quite attractive, and of historical significance.

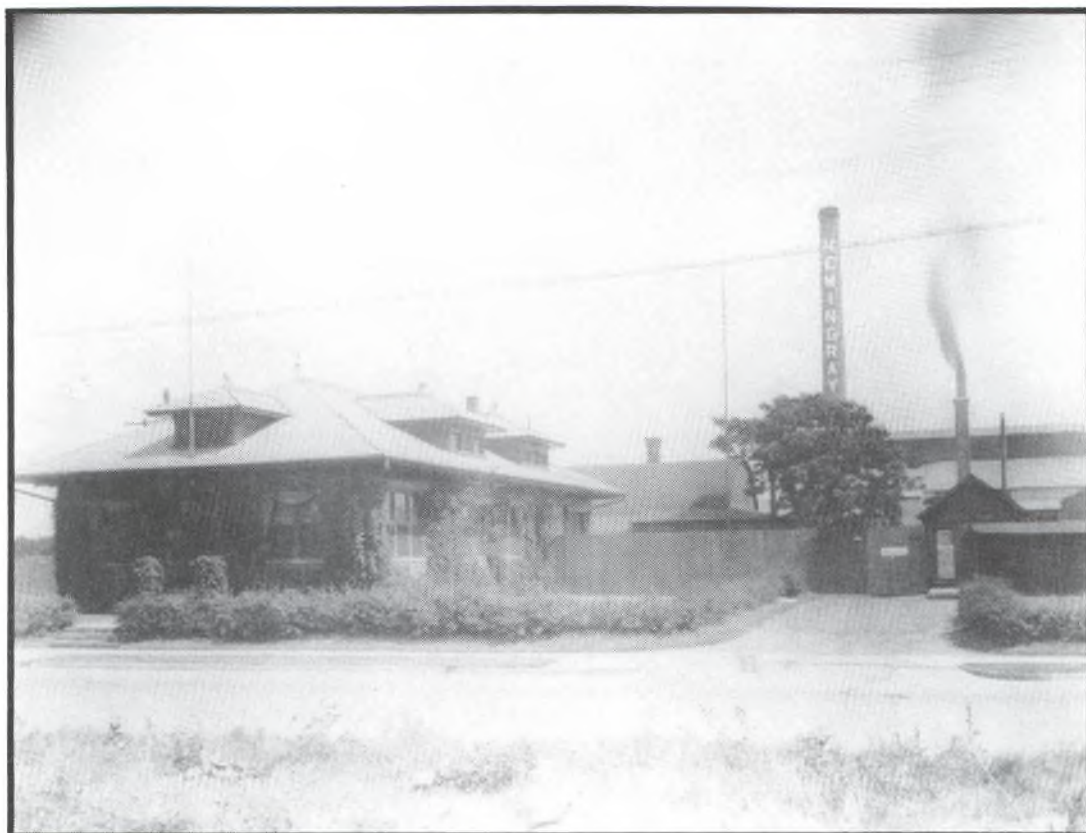

Muncie office and plant looking east.

C. 1924

(Courtesy of Jim Sanders and Mike Sovereign)

*This photo most likely dates back to 1920-1924. The house-like building to the left contains the offices of the company. It was built after the previous building on the site burned in December 1904. And this building itself was destroyed by fire on 21 February 1927. So it was on the site from about 1905 to 1927. Since foliage around the building is quite thick, the photo had to have been taken some years after it was built.*

*The building with the arched (barrel) roof, located to the right and to the rear of the offices, was a ware shed. To the right of this is the building where the barrel staves were dried (note smoke coming out of the chimney). In front of this is the employee's entrance. The brick street running in front is South Macedonia Avenue. The addition to the rear of the office building has already been done (see page 125 for details). This photo is taken facing east from across the street in land owned by the Ball Brothers Manufacturing Company.*

*(This data courtesy of Mike Sovereign, who got it from Dick Bales, who in turn got some of it from Mr. N. R. Woodward and Glenn Drummond)*





Same view as on previous page. Limestone panel at top  
of building reads "HEMINGRAY GLASS COMPANY".  
19 May 1981



Close-up of limestone panel.  
19 May 1981

## **MUNCIE, INDIANA**

### **~ NOW ~**

Much of the Hemingray construction still existed at the Muncie site when I visited it in 1981, although some of it had been removed or added to in the interim by O-I. At the time of my visit, the property was owned by Sheller-Globe of Union City, Indiana, and was for sale. I was granted permission by the owner to take a tour of the property, which was expertly guided by Ruth Crawford, a security guard there along with her husband Jim. Ruth knew a lot about the various locations, and operations of the plant, and I shall always be grateful to her for the time she took to show me around.

Both "A" and "B" furnaces were still there, as was the cullet shed, batch mixer (raw materials silo), cement troughs for washing newly formed insulators, and the pipes from which the natural gas was fed into the furnaces as well as to other parts of the factory. The well from where the water for the plant was taken was still in use, and also where the workers could get a cup of water and a few minutes respite from the heat in the buildings. This was the only source of water from which Hemingray ran the whole factory. There was enough even in case of fire. Water was piped into all parts of the plant. Piles of slag glass and broken insulators still remained out back. The offices were still there, and it was from there that I was given the furnace photos as well as the huge map of the Muncie property. A much-reduced copy is shown below.

The plant became a subsidiary of O-I on 1 June 1933, at the same time as the Root Glass Company of Terre Haute, Indiana. O-I is rumored to have paid one million dollars for each of these two

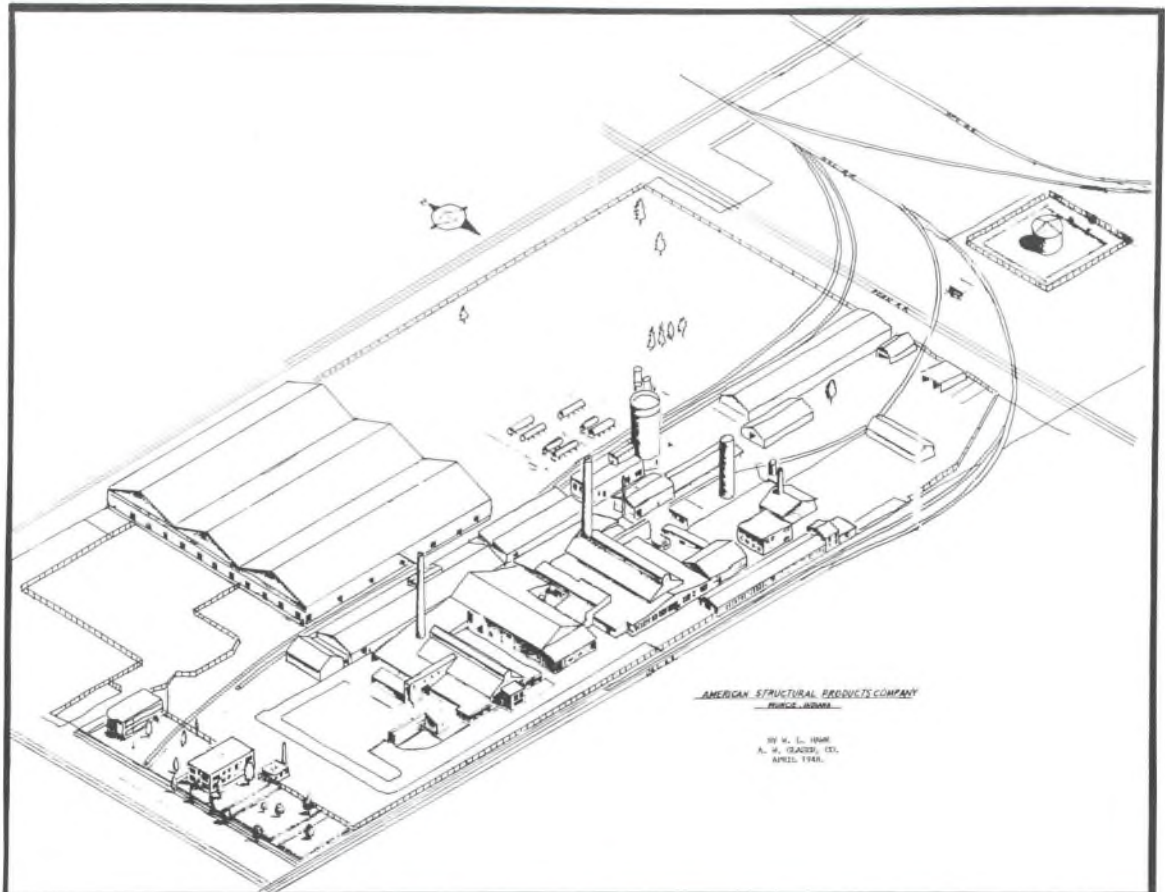

The Muncie factory, aerial view.  
Apr 1948  
Restored by author.  
Author's collection.  
(Courtesy of Ruth Crawford)



## DETAILS OF THE MUNCIE PLANT MAP

The map you see here almost didn't survive. The long story begins this way: When Ruth Crawford took us on the tour of the Muncie property in 1981, we finished with the office building. Papers were scattered all over the floor, including the furnace photos seen elsewhere. Also on the floor was this map. It was huge, probably measuring at least 5' by 10' when unrolled. Ruth asked me if I wanted it, but because of its size, I said no. But she insisted, so we rolled it back up, folding it in the middle to get it into the car.

After we got home, someone wanted to borrow it, but fortunately I had a copy made first, reducing it to 16" by 20". A lot of detail was lost, but it's a good thing we had it done, because I was never able to get the original back.

The original map was covered with mildew and had water damage, which transferred right onto the copy. Also, I had to fold it, which damaged some of the lines. Several times I almost threw it out, thinking that it would never be of use to me or to anyone else.

But when I decided to write this book, I got the map out to see if I could fix it up. By now it was in very bad shape. Even so, I knew that it would add a lot to the book, because I had never seen anything quite like it anywhere else. So I went over all of the tiny lines, almost invisible railroad tracks, etc. I'm not an artist or draftsman, so many repairs are crooked or uneven. Then I used almost a whole bottle of Liquid Paper to take out the mildew and water damage spots. After repairs were made, I had to have it reduced again to fit in the book, and more details were lost. For example, the glass building block didn't show up on some of the buildings, and some doors and windows were "lost".

I have no idea what the purpose of the original map was, unless they were planning a building project. Or perhaps it was drawn for insurance purposes. The map might have been made from an aerial photo, although the map itself was definitely professionally hand-drawn. As time goes by, and these historical buildings are torn down, this map will become more precious. I will always be grateful to Ruth Crawford for insisting that I take it.

The caption below appears on the map. For a short period of time, between approximately 1948 to 1951, the Hemingray Division of Owens-Illinois was known as the American Structural Products Co. Later, in the 1950s, it became the Kimble Division of the Owens-Illinois Glass Co. The A. W. Glaser, Co., was probably the mapmaker.

AMERICAN STRUCTURAL PRODUCTS COMPANY  
MUNCIE, INDIANA

BY W. L. HAWK  
A. W. GLASER, CO.  
APRIL 1948.

## IDENTIFYING SOME OF THE BUILDINGS ON THE MAP

Because the map had to be reduced so much to fit on the page, it will be difficult to identify some of the structures. I'll only identify those I know for certain. I used notes taken at the time of my tour, information from Ern Parkison, and data from maps sent to me by Bob Stahr. Unidentified buildings were probably storage sheds and garages. There were also several ramps leading up to some of the buildings. I thank Bob Stahr also for indentifying some of the structures and for proofreading my notes.

First of all, starting at the left side of the map on Macedonia Avenue are two office buildings. The building with the rounded front was a guardhouse when I was there where visitors were checked in and out. I believe that in Hemingray times it served as an employee rest area where they took their breaks. It was built using glass building block panels. The building to the right of it was the office building so familiar to us in many Hemingray factory photos. It has a limestone panel across the top which reads "HEMINGRAY GLASS COMPANY". The little shed with the small smokestack adjacent to the office was where the barrel staves were dried. Going farther east, the building with the tall smokestack was "A" furnace building which also contained two lehrs. East of that is a service building, but in the early days it was where the tin shop and cooper shop stood. Next in line (or "down the drive", as Ern Parkison says), is "B" furnace building with the other tall stack, containing four lehrs and an engine room on the west end.

The long building along the railroad track at the south end of the property was the mixing room. In earlier times it held the raw ingredients for glassmaking. A small machine shop stood at the east end. After the raw materials silo was built, this building was all machine shop. The building with the shorter heavier stack is located where No. 3 furnace and lehrs once stood. No. 4 furnace also does not show up on this map, and would have been located just east of No. 3 furnace.

At the rear of the property is an oil storage tank. The tall heavy round tower in the center of the map is the raw materials silo, and to the south of that is a small furnace building with the furnace at the west end. The building just behind that one was a coal shed. To the east of the raw materials silo is a long warehouse with the broken glass storage bins located at its west end. Immediately to the west of the raw materials silo is the batch house, where the raw materials were mixed. Farther west, the other long building is a packing room.

The three large buildings to the north were built by O-I and were warehouses also. Just behind them, the objects that look like little logs were fuel storage tanks held off of the ground on "feet". This property was serviced by several industrial railroads. According to a "for sale" sign up in 1981, the property consisted of just over 21 acres.



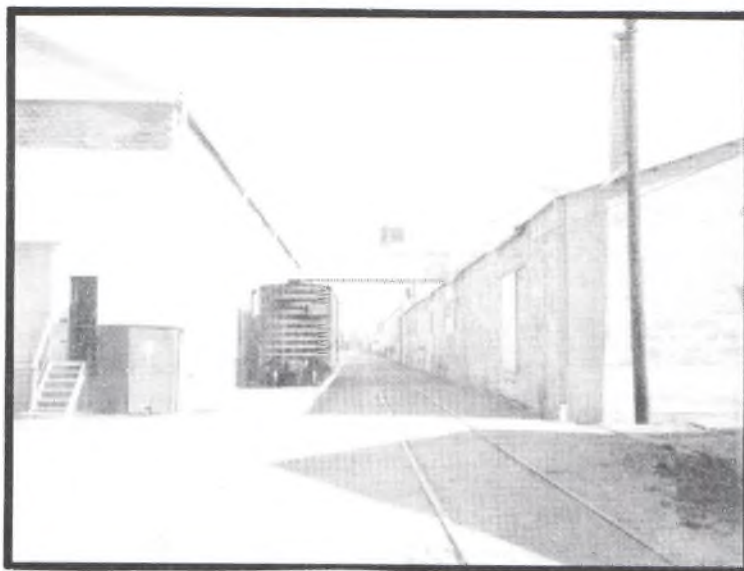

Scene at Muncie. (Raw materials silo at back, newer warehouse building on left, old warehouse on right.)  
Looking east.

C. 1962

(Courtesy of Ruth Crawford)

companies--quite a sum for those days--just to get the patents for Hemingray insulators, and possibly more importantly, Hemingray's unlimited Owens' bottle license, and Root's patent for the now-familiar Coca-Cola bottle. Each plant was shut down forthwith. However, the Hemingray plant resumed operations on a small intermittent scale later that year.

O-I began manufacturing glass building block at Muncie in the mid-1930s. But sales of both the glass block and Hemingray insulators, which O-I had continued to make and sell, began to decline in the 1950s. In 1960 they started producing black and white TV face panels, and in 1964, face panels for color TV. In 1966 they ended production of both the glass block and insulators, and in March of that year, making 25" color TV face panels was the plant's sole activity.

In 1969 the name "Hemingray" was not listed for the first time in the O-I directory. Although by this time the Muncie plant was producing just the TV face plates, its age and layout made it impractical for adaptation to the more modern TV parts, so it was shut down in late summer 1972. All office files were trucked to Toledo, Ohio, the location of the home offices for all O-I plants. The files were sent to dead storage. As of August 1981, Mr. Richard E. Dix, a Muncie supervisor transferred to the plastics division, had an office in the Ohio building. Could there still be some history and data from the Hemingray era stored in some cold basement there? Perhaps a budding Hemingray historian closer to the source will one day find out.





Supposedly where the gas came up out of the ground  
which ran the factory in the early days.  
Date unknown.  
(Courtesy of Ruth Crawford)



Newer warehouses at Muncie built by Owens-Illinois.  
19 May 1981



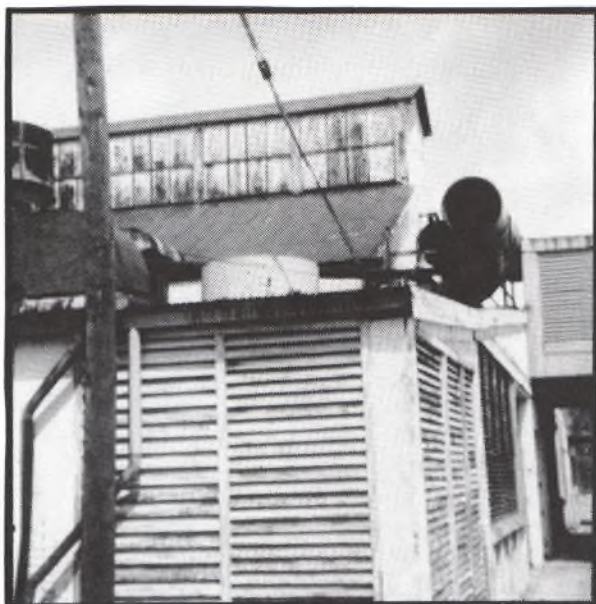

Scenes out back at Muncie. Air-pumping building  
and water-cooled air intake.  
19 May 1981



Pile of insulators out back, resting on a furnace block.  
Lot is mixed; some are CD 137 Hemingray D-990, CD 230.1 Hemingray  
D-512, CD 168 Hemingray D-510, and CD 281 Hemingray 71.  
Date unknown.

(Courtesy of Ruth Crawford)



Raw materials silo with warehouse on right.  
Looking west northwest.  
19 May 1981



Doors into batch mixer by raw materials silo.  
Looking north.  
19 May 1981





At east end; a tank stack and monitors.\*  
Looking west.  
19 May 1981



Various service buildings at extreme east end.  
Taken to left of previous photo.  
Looking west southwest.  
19 May 1981

\* A monitor is a long low extension built along and upon the ridge of a factory building, the sides of which are open or perhaps louvered to permit ventilation of foundry or glass factory buildings where lots of smoke and heat are generated. (My thanks to Ern Parkison for this explanation.)



Another view of a long warehouse building with broken glass storage bin in foreground. Note cullet sign still mounted on the building.  
Looking east.  
19 May 1981



Close-up of cullet sign removed from warehouse building in above photo, with permission of Ruth Crawford.  
19 May 1981  
(Courtesy of Mr. N. R. Woodward)



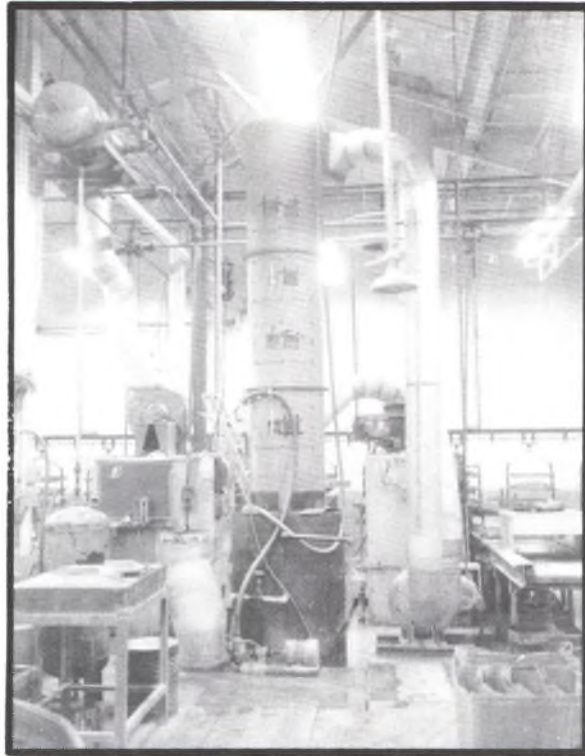

Making TV face panels at Muncie,  
probably in "A" or "B" furnace building.  
1964  
(Courtesy of Ruth Crawford)

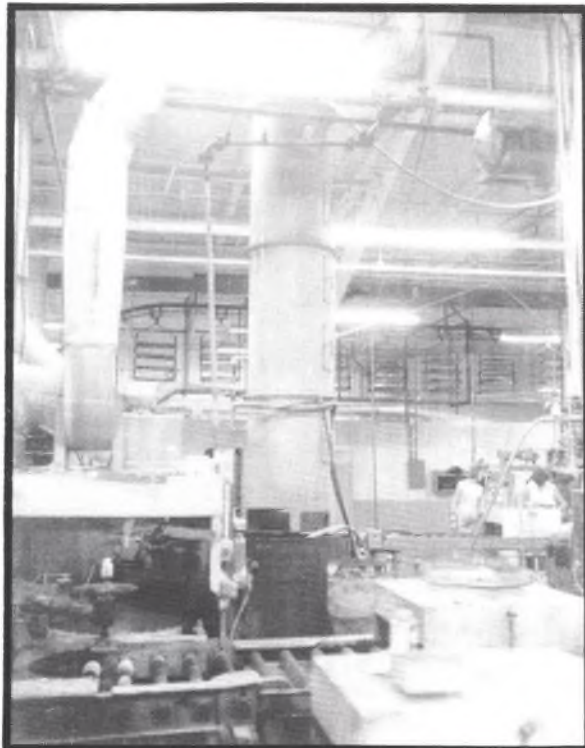

# Owens-Illinois Will Close Factory Here

## 337 Employed at TV Tube Plant

Owens-Illinois, Inc., announced today that it is closing "with great reluctance" its 82-year-old Muncie plant on Macedonia Ave.

The plant, which currently has 337 employees, has been producing face panels for color television picture tubes since 1964.

"The decision to close the plant was made with great reluctance and only after years of efforts to keep the plant operating," Sam F. Schillaci, vice president of the company's Consumer and Technical Products Division and general manager of Television Products, said today. "However, we have no alternative because the plant's age and its layout make it impractical to adapt it to the production of the type of color television parts that now are required by the industry.

"In order to meet the demands of color television set manufacturers, Owens-Illinois would, in effect, have to completely rebuild the Muncie plant. Since our larger modern plants at Columbus, Ohio, and Pittston, Pa., are now supplying all of the needs of the available market, and can continue to do so, such a new plant is not needed in the foreseeable future."

### NO USE FOUND FOR PLANT

Schillaci said he had explored with other company divisions the possibility of their taking over the Muncie plant for their operations.

"Unfortunately, none of them have any need for the plant now," he added.

The plant's batch, furnace and forming departments will cease operations at 7 a.m. on Saturday, July 15, while other departments will continue operating until their work is completed. The plant is expected to be completely closed by Sept. 1.

A small maintenance and security force will remain at the

plant after manufacturing operations end.

In a letter to plant employees, Schillaci assured them that Owens-Illinois would do everything possible to help them find other employment in the Muncie area. Long-service employees who are eligible for early retirement will be offered that option and the company also will contact other O-I plants in the interest of plant employees who are willing to move to other cities.

Eligible employees will be paid severance pay in accordance with company policy, Schillaci said.

The Owens-Illinois plant was built in 1890 by the Hemingray Co. to manufacture its world-famous Hemingray glass insulators for use by the communications industry. The Hemingray company was founded in Cincinnati in 1848 but moved here 42 years later as a result of flood damage to its Cincinnati plant and the discovery in Muncie of natural gas.

Owens-Illinois bought the plant in 1933 and two years later shifted the manufacture of its then-popular glass block to Muncie. Sales of both glass block and the Hemingray insulators began to decline in the 1950's and the plant finally ended production of both items in 1968.

Owens-Illinois began trying to find other uses for the Muncie plant as early as 1960, when it started producing black and white television parts for assembly by the company's television bulb plant at Columbus, Ohio. The plant has made color television face panes since 1964.

The Muncie Evening Press

20 Jun 1972

(Courtesy of Glenn Drummond)



Of the three Hemingray plants, all are gone now, with the exception of whatever buildings and equipment exist at Muncie at this writing (1997). Of the 85 years the Hemingray Glass Company was in business, eight were spent at Hammond Street in Cincinnati, 41 at Covington, and 46 at Muncie. (Of course, business overlapped at more than one location for a few years.)

The Hemingray Glass Company had an illustrious and lengthy career and produced a greater variety of insulators, both designwise and colorwise, than any other insulator company; and just as their durability has proven to be everlasting, their beauty will be also.

(See "The 'Catch-all' Room" page 442 for a copy of a speech given at an awards ceremony at Muncie in 1948, as well as a short history dated around 1968 on page 392. See "The Mail Room" page 245 for a 1976 letter from O-I to Glenn Drummond.)



The Muncie factory office building.  
Now an apartment building.  
Nov 1995  
(Courtesy of Bill Morgan and Pat Mundy)

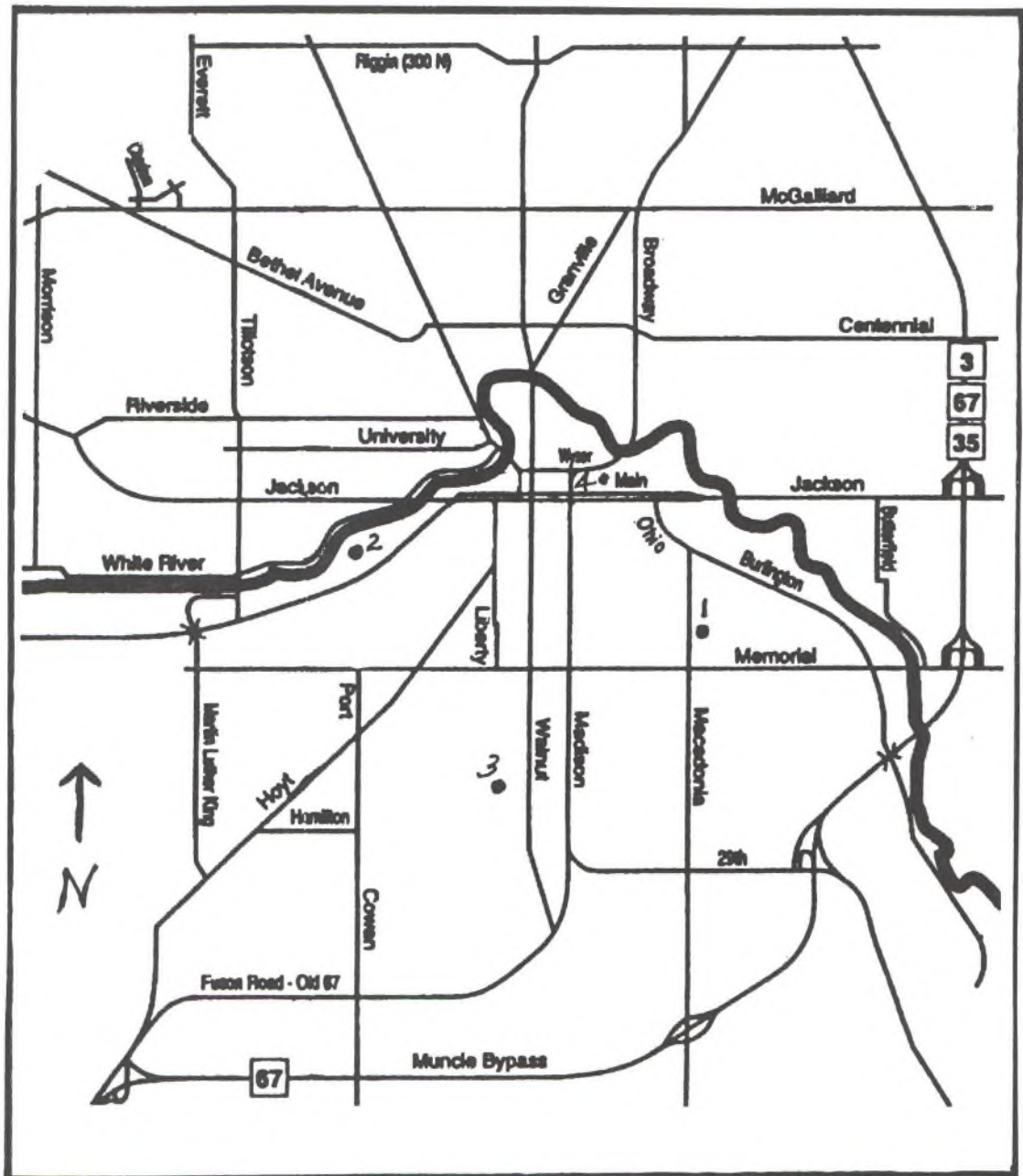

Map of Muncie, IN  
 Dots show historical sites. #1, the Hemingray Glass Co.  
 #2, Beech Grove Cemetery. #3, the Hemingray dump.  
 #4, the Ralph Hemingray home on E. Washington Street.  
 (Courtesy of Bob Stahr)



## THE HEMINGRAY DUMP



"Down in the Dumps"

Glenn Drummond and Jerry Turner at the Hemingray dump.  
1975

Photo by Ed Smith  
(Courtesy of Glenn Drummond)

Glenn writes, "The 'stuff' in the background is glass block shards. Words just cannot describe the volume of the glass block debris that covered the ground. One had to dig through it to reach other dumped items. Prior to our visits, others had dug with backhoes to reach the test insulators that were recovered from there."

Most people are not aware of the fact that the Hemingray dump was not anywhere near the Muncie factory, but was across town. (Conversely, many who dug the dump area had no idea that most of the factory was still standing in another part of town.) I hesitate to give the exact location of the dump, because even though it is

now covered over completely, I wouldn't want to cause a mass rush to the place for the sake of nearby residents. I will say that it was located on a railroad spur behind a foundry; the nearby railroad track served the foundry. From what I've been able to find out, Hemingray didn't pay to dump there. And no evidence has been found that any other glassworks used this dump.

Even when I was there in 1981, there was nothing left to see, and to dig would have been a monumental job. However, those fortunate enough to dig the area in the early days found many experimental pieces; carnival, flashed, and colored glass, and pieces from the "E"-series, in addition to the standard items, along with parts of O-I glass block.

## **HEMINGRAY HOMES**

Many of the Hemingray people lived in many homes in their lifetimes, and I don't have photos of each place. But I have managed to get photos of some of their homes. In the case of Robert Hemingray, I just have a photo of the site in Covington; the house has been torn down, and the present building has housed several different businesses over the years.

With the help of friends like Franklin Jaquish in Covington and Bill Morgan and Pat Mundy in Muncie, I am able to present the photos you see here of some Hemingray homes. I truly appreciate the time and expense they incurred in order to help me, and none of them would take a penny for what they did. I thank you all for these lovely photos.

### **THE RALPH HEMINGRAY HOME**

Following are some notes about the Ralph Hemingray home excerpted from a letter to me from the present owner, Bill Morgan:

*Enclosed is a print of the photo. The quality is rather poor, as it has gone through so many generations to get to me. The photo came from the 1903-04 Muncie City Directory...*

*The best I can tell, the house was built around 1886 by the Van Buskirk family. Certain evidence would suggest that they may have been farmers who suddenly became rich when natural gas was found on their property. They owned the house until 1899, when, apparently, their fortunes changed and they were unable to repay a mortgage.*

*On the eve of a Sheriff's sale, the house was bought by James Daly and his wife Harriet, who are, most likely, the people on the porch in the photo. Daly was president of the Muncie and Rochester Land Development Company, and was one of the community leaders who wrote to Andrew Carnegie requesting that he fund a library for Muncie (which he did - it's beautiful and still in use). James and Hannah Quinlan owned the house from 1907 to 1910.*



# See the TEATS on the PETTICOAT

They take all the moisture from  
the inner and outer surface of the  
insulator and keep the pin dry



Deep Groove  
Double Petticoat



Cable

## HEMINGRAY GLASS CO.

Established 1848

Incorporated 1870

COVINGTON, KY.

Factories - - - MUNCIE, INDIANA

Company ad.  
The Electrical World  
C. 1900  
(Courtesy of Mike Sovereign)



Ralph Hemingray home, 824 E. Washington St.  
Muncie, IN  
C. 1902

The Muncie City Directory, 1903-1904  
(Courtesy of Bill Morgan)

*Ralph and Eva Hemingray bought the house in 1910. We suspect that it was Ralph who did some extensive remodeling, changing the first floor plan and details from the original Queen Anne style to more of a Mission/Craftsman aesthetic. Ralph died in 1920 and in 1923 Eva sold the house to her son-in-law, Philip McAbee, who, I believe, was president of Hemingray Glass and had married Ralph's daughter Mintie Carroll.*

*McAbee died in 1948, and the house was sold to Dean D. Zimmerman, who may have been related to a Zimmerman who was an executive for Hemingray. In later years, Zimmerman did some pretty awful things to the house so he could rent the upstairs bedrooms.*





Ralph Hemingray home.  
19 Sep 1995  
(Courtesy of Bill Morgan and Pat Mundy)

*In 1976, Zimmerman sold the house to the Cambridge House, a social service agency that used the building as a group home for troubled teenage girls. They really butchered the place. In 1980, they closed the group home and let the house stand vacant until I bought it in 1984.*

*...Budget constraints have made the restoration a mostly do-it-yourself proposition, so it is going very slowly...*

**(I thank Bill Morgan very much for such a detailed history of this beautiful old home)**



Ralph Hemingway home.  
7 Aug 1996  
(Courtesy of Bill Morgan and Pat Mundy)





Daniel Hemingray home, 636 Greenup St., NE corner.  
Covington, KY  
Jul 1983  
(Courtesy of Franklin Jaquish)



Same, south side of house (E. 7th St.).  
Jul 1983  
(Courtesy of Franklin Jaquish)



Robert C. Hemingray home, 616-618 Garrard St. (double house).  
Covington, KY  
Jul 1983  
(Courtesy of Franklin Jaquish)

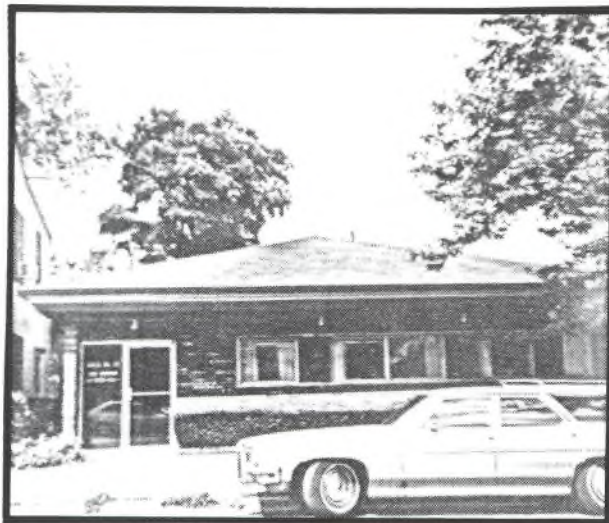

Site of Robert Hemingray home, 219 Garrard St.  
Now a lawyer's office building.  
Covington, KY  
Jul 1983  
(Courtesy of Franklin Jaquish)



RESIDENCES OF HEMINGRAY PEOPLE IN COVINGTON, KENTUCKY  
1860-1920

(Information taken from Covington directories, courtesy of Bob Stahr)  
(Data appearing to be in error, and comments,  
will be shown in brackets)

(Please see page 85 for explanations of most abbreviations)

1860

Richard Evans, n.s. 4th b. Madison & Scott  
Anthony Gray, n.s. Park b. 3rd & 4th  
James A. S. Gray, s.s. 5th b. Scott & Madison  
Ralph Gray, n.s. 3rd b. Scott & Madison  
Daniel Hemingray, n.s. 3rd b. Scott & Greenup  
Robert Hemingray, n.s. 3rd b. Scott & Greenup

1861

Richard Evans, e.s. Madison b. 2nd & 3rd  
Anthony Gray, Park St. b. 3rd & 4th  
Ralph Gray, n.s. 2nd b. Scott & Madison  
Robert Hemingray, n.s. 3rd b. Scott & Greenup  
Samuel Hemingray, w.s. Craig b. 7th & Bremen

1866

Richard Evans, 3rd e. of Garrard  
James L. Foley, n.e.c. 7th & Sanford  
Robert Hemingray, s.w.c. Front & Garrard  
Samuel Hemingray, s.w.c. Craig & Bremen  
Susan Gray (widow), n.s. 3rd b. Scott & Madison

1867

Richard Evans, s.s. 3rd e. of Garrard  
James L. Foley, E. Russell & River Bank  
Robert Hemingray, res. country  
Ann Hemingray, s.w.c. Craig & Bremen  
Robert Gray, s.s. 5th b. Scott & Madison  
James A. S. Gray, s.s. 5th b. Scott & Madison  
John Gray, s.s. 5th b. Scott & Madison  
Mary Gray, s.s. 5th b. Scott & Madison

1869

Robert Hemingray, 219 Garrard  
Robert Gray, 25 E. 5th  
John Gray, 25 E. 5th  
James A. S. Gray, 25 E. 5th  
James L. Foley, 89 W. Front  
Richard Evans, 65 W. 3rd  
Mrs. Ralph Gray (widow), s.s. 4th b. Madison & Russell

1880

Richard Evans, 65 W. 3rd  
Richard G. Evans, 65 W. 3rd  
Anna Gray, 219 Garrard  
Kate Gray, 219 Garrard  
Daniel Hemingray, 219 Garrard  
Robert Hemingray, 219 Garrard  
Ralph Hemingray, 58 W. 4th  
Robert C. Hemingray, 219 Garrard  
Edward Swasey, 726 Garrard  
Mrs. Ralph Gray (widow), 45 W. 4th

- 1880 continued  
 Robert C. Gray, 45 W. 4th  
 Tutie C. Gray [sister of Robert Cairns Gray], 45 W. 4th  
 John C. Gray, 96 E. 4th  
 Ralph Gray, 96 E. 4th
- 1882  
 Richard Evans, 514 Russell  
 Richard G. Evans, 514 Russell  
 James Gill, 50 E. Front  
 Anna Gray, 219 Garrard  
 Kate Gray, 219 Garrard  
 John C. Gray, 150 E. 3rd  
 Ralph Gray, 150 E. 3rd  
 Mrs. Ralph Gray (widow), 45 W. 4th  
 Robert C. Gray, 45 W. 4th  
 Tutie C. Gray, 45 W. 4th  
 Mintie Hemingray, 219 Garrard  
 Ralph Hemingray, 58 W. 4th  
 Robert Hemingray, 219 Garrard  
 Robert C. Hemingray, 618 Garrard
- 1884  
 Richard Evans, 1549 Madison  
 Richard G. Evans, 1549 Madison  
 James L. Foley, Cincinnati, Ohio  
 James Gill, 50 E. Front  
 Ann Gray (widow), 45 W. 4th  
 Anna Gray, 219 Garrard  
 Robert C. Gray, 45 W. 4th  
 Daniel Hemingray, 219 Garrard  
 Miss M. [Mintie] Hemingray, 219 Garrard  
 Robert Hemingray, 219 Garrard  
 Robert C. Hemingray, 618 Garrard  
 Ralph Hemingray, 58 W. 4th  
 Ralph Gray, 150 E. 3rd  
 John C. Gray, 150 E. 3rd  
 Kate Gray, 219 Garrard
- 1886  
 Robert Hemingray, 219 Garrard  
 Miss M. Hemingray, 219 Garrard  
 Anna Gray, 219 Garrard  
 Mrs. Ralph Gray (widow), 45 W. 4th  
 Robert C. Gray, 45 W. 4th  
 Robert C. Hemingray, 618 Garrard  
 Ralph Hemingray, 58 W. 4th  
 Daniel Hemingray, n.e.c. Greenup & 7th  
 John C. Gray, 729 Garrard  
 Ralph Gray, 729 Garrard  
 James Gill, 734 Greenup  
 James Foley, Cincinnati, Ohio  
 Richard Evans, 1549 Madison  
 Richard G. Evans, 634 Greenup
- 1888  
 Richard Evans, 1549 Madison  
 Richard G. Evans, 634 Greenup



1888 continued

James Foley, Cincinnati, Ohio  
James Gill, 734 Greenup  
Ann Gray (widow), 45 W. 4th  
Anna Gray, 219 Garrard  
Robert Hemingray, 219 Garrard  
Ralph Hemingray, 58 W. 4th  
Daniel Hemingray, n.e.c. 7th & Greenup  
Robert C. Hemingray, 618 Garrard  
John C. Gray, 729 Garrard

1890

Mary E. Swasey, 219 Garrard  
Robert Hemingray, 219 Garrard  
Daniel Hemingray, [219 Garrard]  
Annie Gray, 219 Garrard  
Richard Evans, 1549 Madison  
Ralph Hemingray, 58 W. 4th  
John C. Gray, 1557 Madison  
Ann Gray (widow), 45 W. 4th  
Robert C. Gray, 45 W. 4th  
James Gill, 734 Greenup

1892

Richard Evans, 1549 Madison  
Ralph Hemingray, 58 W. 4th  
Daniel Hemingray, n.e.c. 7th & Greenup  
Robert Hemingray, 219 Garrard  
Mary E. Swasey, 219 Garrard  
Anna Gray, 219 Garrard  
John C. Gray, 1557 Madison  
Ann Gray (widow), 45 W. 4th  
Robert C. Gray, 45 W. 4th

1894

William E. Evans, 1549 Madison  
Richard Evans, 1549 Madison  
Robert Hemingray, 219 Garrard  
Mary E. Swasey, 219 Garrard  
Anna Gray, 219 Garrard  
Ann Gray (widow), 45 W. 4th  
Robert C. Gray, 45 W. 4th  
Daniel Hemingray, n.e.c. 7th & Greenup  
Ralph Hemingray, Muncie, Indiana

1895

Richard Evans, 1549 Madison  
W. Edgar Evans, 1549 Madison  
Wm. E. Evans [same as above], 1549 Madison  
Ann Gray (widow), 45 W. 4th  
Robert C. Gray, 45 W. 4th  
Daniel Hemingray, n.e.c. 7th & Greenup  
Ralph Hemingray, Muncie, Indiana  
Robert Hemingray, 219 Garrard  
Mary E. Swasey, 219 Garrard

1897

Richard Evans, 1549 Madison  
W. E. Evans, 1549 Madison

- 1897 continued  
 Robert C. Gray, 45 W. 4th  
 Daniel Hemingray, n.[w.]c. 7th & Greenup  
 Robert Hemingray, 219 Garrard  
 Ralph Hemingray, Muncie, Indiana
- 1898  
 Mary J. Evans (widow), 1549 Madison  
 W. Edgar Evans, 1549 Madison  
 Robert Hemingray, Sr., 219 Garrard  
 Ralph Hemingray, Muncie, Indiana  
 Robert C. Hemingray, Muncie, Indiana  
 Daniel Hemingray, 636 Greenup  
 Ann Gray (widow), 45 W. 4th  
 Robert C. Gray, 45 W. 4th  
 C. Hemingray, 165 E. 2nd [not yet known who this is]
- 1900  
 Mary J. Evans, 1549 Madison  
 W. Edgar Evans, 1549 Madison  
 Anna Gray, 45 W. 4th  
 Robert C. Gray, 45 W. 4th  
 Daniel Hemingray, 636 Greenup  
 Mary Hemingray (widow), 219 Garrard  
 Bradford Shinkle, 165 E. 2nd  
 Ralph Hemingray, Muncie, Indiana
- 1902  
 Mary J. Evans (widow), 1549 Madison  
 Ann Gray, 45 W. 4th  
 Robert C. Gray, 45 W. 4th  
 Daniel Hemingray, 636 Greenup  
 Bradford Shinkle, 165 E. 2nd
- 1906-1910 names drop out. Daniel Hemingray listed at 636 Greenup.
- 1912  
 Daniel Hemingray listed at Glendale, Ohio. However, he died in 1911.
- 1916  
 W. Edgar Evans, flat 7, Marzella (North)  
 A. C. Shinkle, Cincinnati, Ohio
- 1917  
 W. Edgar Evans, flat 7 523 Greenup [Marzella (North)]
- 1920  
 W. Edgar Evans, flat 5 523 Greenup
- No more listings after 1923



RESIDENCES OF THE HEMINGRAYS IN MUNCIE, INDIANA  
1889-1924

(Courtesy of the Muncie Public Library and Bob Stahr)  
(Data appearing to be in error and editorial additions  
will be in brackets)

1889

Ralph G. Hemingray, boards Blount house

1891-1892

Ralph G. Hemingray, boards 411 W Howard

Robert C. Hemingray [Jr.], home 122½ E. Jackson

1893

Robert & Mary E. Hemingray, 521 E. Jackson

Ralph G. Hemingray, boards 521 E. Jackson

Robert [Robin?] Hemingray, home 404 E. Washington

Robert C. Hemingray [Jr.], home 403 E. Washington

1897-1900

Miss Llewellyn Hemingray, home 411 W. Howard

Ralph G. Hemingray, boards 411 W. Howard

Robert C. Hemingray [Jr.], home 1412 E. Main

1901-1910

Miss Lewellyn [sic] M. Hemingray, home 411 E. Gilbert

Miss M. [Mintie] Carroll, artist, suite 213 The Johnson,  
home 411 E. Gilbert

Ralph G. Hemingray, boards 411 E. Gilbert

Miss Susan Ashley Hemingray, home 222 E. Adams

1911-1912

Ralph G. Hemingray, home 824 E. Washington

Llewellyn Hemingray, home 824 E. Washington

1913-1914

Lulu [Llewellyn] Hemingray, home 824 E. Washington

Ralph G. Hemingray, home 824 E. Washington

1915-1920

Ralph G. Hemingray, 824 E. Washington

1921-1924

Eva H. Hemingray, widow of Ralph, 824 E. Washington

TRADE MARK  
STANDARD HEMINGRAY INSULATORS  
REGISTERED.





# HEMINGRAY THINGS

## PART III



CD 214





## **HEMINGRAY THINGS PART III**

Few things in this world are as pretty as the compound called "glass". Webster's Dictionary defines it as "a hard, brittle substance, usually transparent or translucent, made by fusing silicates with soda or potash, lime, and, sometimes, various metallic oxides." Just when man began making this unique material is not known for certain. But glass beads have been found in Egypt that are believed to be some 4,000 years old. Job, the Biblical character who lived in what is now Arabia 3,500 years ago, listed glass alongside gold for preciousness, when he stated that gold and glass could not be compared to wisdom.

The Egyptians were skilled in the molding, cutting, grinding and engraving of glass, and they even knew how to imitate the colors of some of the precious stones. The Greeks and Phoenicians were accomplished glassmakers, as were the Romans, who further developed the craft of glass cutting.

So, for many centuries, man has known how to make things from glass that have pleasing form and beauty, for useful purposes, as

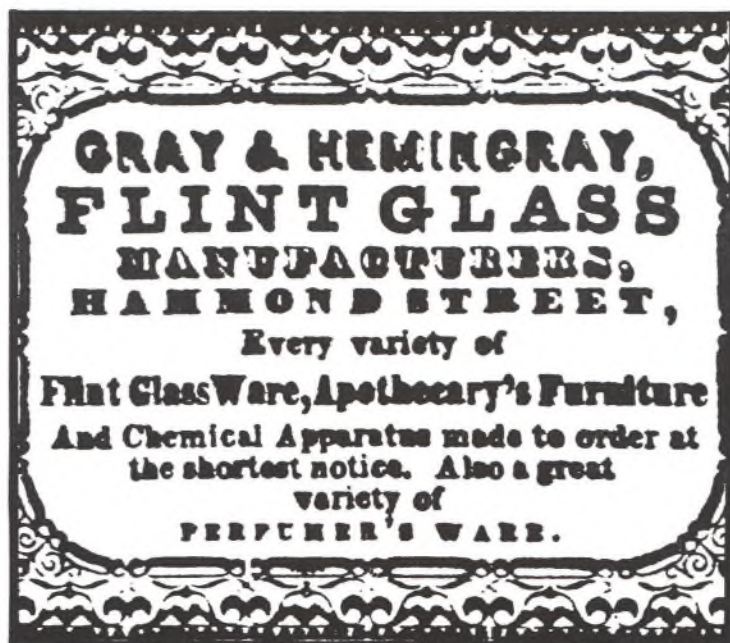

Ad for Gray & Hemingray.  
Williams' Cincinnati Directory  
& Business Advertiser  
1849-1850  
Printed 1849  
(Courtesy of Glenn Drummond)

**R. HEMINGRAY & CO.,**  
 No. 68 Walnut St., Cincinnati, O.,  
 Manufacturers of  
**FLINT, GREEN & BLACK GLASS,**  
 CONSISTING OF  
 Fruit Jars, Lamps, Lanterns, Chimneys, Brandies, Hock Wines, Demi-  
 johns, Screw Cap Flasks, Tumblers, and a general variety of  
 Table Ware. Also, Philosophical Apparatus, and Round  
 and Oval Shades for Artificial Flowers and Statu-  
 ettes. Solar, Sun and Comet Burners on  
 hand in large quantities.

---

N. B.—Our PATENT FRUIT JARS, manufactured exclusively by us,  
 stand unrivaled for preserving qualities, and have the best  
 reputation of any Jar in the West.

Liberal Discount to the Country Trade.

Ad for R. Hemingray & Co.  
Williams' Cincinnati Directory  
& Business Advertiser  
 1869  
 (Courtesy of Glenn Drummond)

well as decorative. Glassware is a very collectible commodity. Its sparkling, eye-catching quality has long endeared it to the hearts of millions of collectors the world over.

The forming of glass into the shape of insulators is certainly one of the most beautiful arts accomplished by man; and Hemingray is no doubt a familiar name to anyone involved with insulators. Their insulators are of unsurpassed quality, of beautiful design, and are varied in form. Probably every general insulator collection has at least one Hemingray in it, and several collectors have chosen Hemingray glass as their specialty. A complete Hemingray collection would be a beautiful sight to behold.

The Hemingray Glass Company produced a huge volume of insulators during their 85 years of operation. Within that immense quantity was a diversity of style; there were about 97 different designs in the Hemingray line, and more if you count some obscure experimentals or variations not carried under a separate style number by Hemingray. And there would be at least ten more if you include Kimble, Chambers, and Surge styles which were Hemingray products. (The Hemingray No. 9, CD 106, may have been made in more numbers than any other insulator, and the Hemingray No. 42, CD 154, may have run a close second.)

Hemingray also manufactured a variety of colors. Just about every color of the rainbow was represented with the exception of



a true red. And some colors found in Hemingray insulators are not readily seen in the rainbow, such as smoke, clear, and the many shades of amber. Hemingray also made insulators over a longer period of time than any other insulator-producing company.

During its many years in existence, and especially in the early years, the Hemingray Glass Company produced an astounding variety of items. If it was pressed or blown glassware, Hemingray probably made it at one time in their history. According to company ads, brochures, and patents that have survived, a list of some of the items, other than insulators, reads as follows: Lamps, lamp chimneys, lanterns, fruit jars, demijohns (beverage bottles in basketwork), carboys (large glass bottles for industrial chemicals, enclosed in wooden crates), brandies, screw cap flasks, hock wines (tall slim bottles), beer bottles, mineral water bottles, candy jars, fish globes (bowls), tumblers, decanters, battery jars, electric (street) light globes, packing bottles, lamp glasses, apothecary shop (pharmacy) furniture, perfumery glass, glass milk pans, cut glass, refrigerator water bottles, pressed and blown tableware, and kerosene oil cans (approximately one foot tall glass jar with tin jacket). Also, according to The Antique Trader Weekly, 17 August 1976, Hemingray exhibited paperweights at the 13th Annual Mechanics' Fair in Cincinnati in 1854, receiving the First Class Diploma for their entry. This is quite an impressive list, even though it is no doubt incomplete.

**R. HEMINGRAY & CO.,**  
No. 68 Walnut Street, Cincinnati, Ohio,  
—◊ MANUFACTURERS OF ◊—  
**Flint, Green and Black Glass,**  
—◊CONSISTING OF◊—  
Fruit Jars, Lamps, Lanterns, Chimneys, Brandies, Hock Wines, Demijohns,  
Screw Cap Flasks, Tumblers, and a general variety of Table Ware.  
Also, Philosophical Apparatus, and Round and Oval Shades  
for Artificial Flowers and Statuettes. Solar, Sun  
and Comet Burners on hand in large  
quantities.  
N. B.—Our PATENT FRUIT JARS, manufactured exclusively by us, stand unrivaled for pre-  
serving qualities, and have the best reputation of any Jar in the West.  
**LIBERAL DISCOUNT TO THE COUNTRY TRADE.**

Ad for R. Hemingray & Co.  
Williams' Cincinnati Directory  
& Business Advertiser  
1870  
(Courtesy of Glenn Drummond)

# Hemingray Glass Co.,

No. 68 Walnut St., Cincinnati, Ohio,

←MANUFACTURERS OF←

## Flint, Green and Black Glass,

CONSISTING OF

Fruit Jars, Lamps, Lanterns, Chimneys, Brandies, Hock Wines, Demijohns, Screw Cap Flasks, Tumblers, and a general variety of Table Ware. Also, Philosophical Apparatus, and Round and Oval Shades for Artificial Flowers and Statuettes. Solar, Sun and Comet Burners on hand in large quantities.

Our PATENT FRUIT JARS, manufactured exclusively by us, stand unrivaled for preserving qualities, and have the best reputation of any Jar in the West.

LIBERAL DISCOUNT TO THE COUNTRY TRADE.

Company ad.

Williams' Cincinnati Directory  
& Business Advertiser

1871

(Courtesy of Glenn Drummond)

## WHY GLASS?

Insulators have been made of many materials, especially in modern times. Some that come to mind are porcelain, wood, rubber, polyethylene, plastic, fiberglass, and composition. Even in earlier times some were manufactured in wood and mica. But glass insulators have been the most popular of all, on North American communication lines, as well as those of some other countries throughout the world.

Rather than list all of the reasons why glass is superior to other materials, I have reproduced a portion of a Hemingray catalog (Bulletin No. 1, 15 May 1921), wherein they give the many positive qualities of glass. This catalog was copied for me by Mike Sovereign years ago. (See "The Ad Room" page 353.)

## COMPANY EMBOSSINGS

"Dec. 19, 1871"

I won't get into too much detail on this subject, but let's hit some highlights regarding a few embossings, just on insulators. Hemingray embossed their earlier insulators with the "Dec. 19, 1871" embossing, and there is a possible explanation for this. The 1871 patent of Hemingray's was contested by Homer Brooke, and Hemingray almost lost the rights, which would have doomed their insulator business. Due to an oversight at the Patent Office, both Brooke and



Hemingray received a patent for forming the cavity or pinhole in an insulator. The patents were issued just 22 days apart. The basic difference was that Brooke's method used a rotating downward motion; Hemingray's eliminated the rotating motion. (See "The 'Catch-all' Room" page 439 for the official report.)

The court battles of 1871 were actually a three-way fight between James M. Brookfield and Robert Hemingray, both as major manufacturers at the time, and Homer Brooke, a machinist and manufacturer of molds for glass manufacturers. Since Brookfield made millions of insulators in the following years referring to the Cauvet patent, it would seem the courts ruled in his favor insofar as the right to manufacture a threaded insulator. By what means Robert Hemingray was able to continue uninterrupted, is not clear. Court records for that entire period relating to threaded insulators could probably create a lifetime of research. But whatever transpired, it was the 1871 patent that "made it" for Hemingray, and may have influenced his decision to emboss "1871" on the earlier pieces. (Although the machine for which the patent was issued wasn't all that great, it was the beginning. An easier-to-use press was patented in June 1881, and an examination of insulators will show that there must have been several presses used along the way.)

**HEMINGRAY**  
**GLASS CO.,**

No. 68 WALNUT STREET, CINCINNATI, O.



Lamps, Lanterns, Fruit  
Jars, Shop Furniture,  
Demijohns, Brandies,  
Flasks, Hock Wines,  
Beer Bottles, Mineral  
Water Bottles, Candy  
Jars, Carboys, Fish  
Globes, Etc.

SOLE MANUFACTURERS OF THE

**"ELGIN OIL CAN."**

Company ad.  
Covington City Directory  
1878  
(Courtesy of Franklin Jaquish and  
the Kenton County Public Library)



Hemingray lamp next to CD 145 H. G. CO. PETTICOAT beehive  
in the same color amber. Chimney and burner  
removed for photographing. Shown  $\frac{1}{2}$  actual size.

Photo by John and Carol McDougald  
(Lamp in the collection of Bob Stahr.  
Beehive in the collection of Bill Meier.)



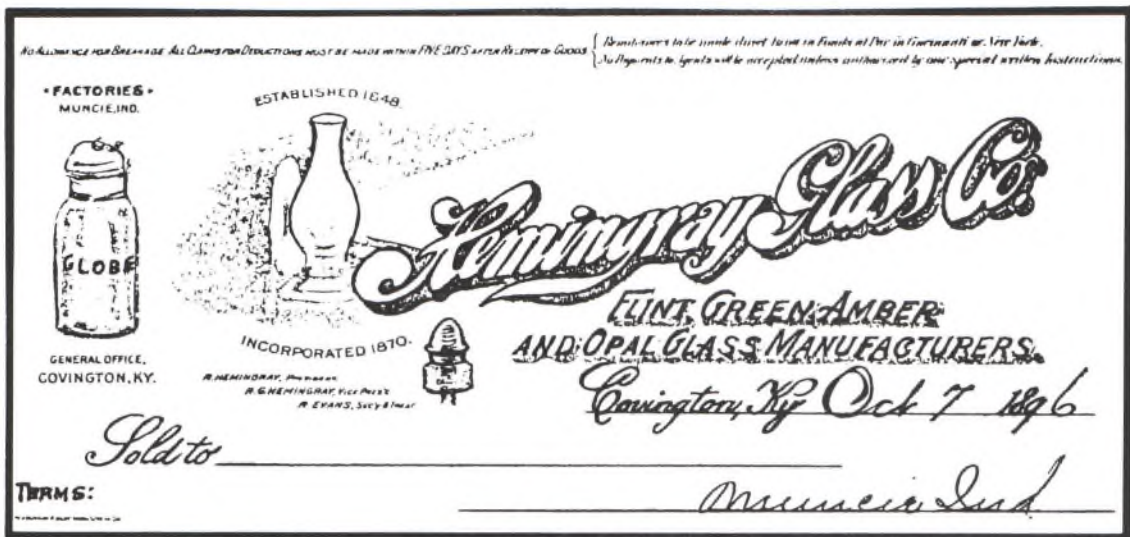

Hemingray invoice-head.  
7 Oct 1896  
Restored by author.  
(Courtesy of Ern Parkison)

"H. G. CO."

As already reported, the Hemingray and Gray brothers were very close. There was probably an agreement among the four not to mark their product. To some extent, this was the tradition of the time; few glassmakers marked their product. Of all the bottles and jars that were made at that time (1848-1863), only a few have been seen with a "G & H" (Gray and Hemingray) marking, only one container with the name spelled out, and a few fruit jar lids that have the name cast in metal. After the death of Ralph Gray in 1863, the name became "Hemingray Bros. & Co." until Samuel Hemingray's death in 1866. It was then known as "R. Hemingray & Co." until it was incorporated as the "Hemingray Glass Co." in 1870. Although Robert Hemingray was not reluctant to drop "Gray" from the name of the company when they died, his close ties to the Gray families might have prevented him from using his own name as the company's mark.

The earliest use of the "H. G. CO." mark that can be determined is on the base of beer and soda bottles made sometime in the 1870s. At this time you find Hemingray's biggest competitor, Brookfield, putting his name and address on his insulators. Samuel Oakman and Hemingray's biggest tormentor, Homer Brooke, did likewise. Hemingray may have been reluctant to do the same.

"HEMINGRAY"

When Robert Hemingray died in 1898, Ralph and his brothers may have had a different attitude from that of their father, and wanted to have a more clear company mark. Insulators made after 1900 were

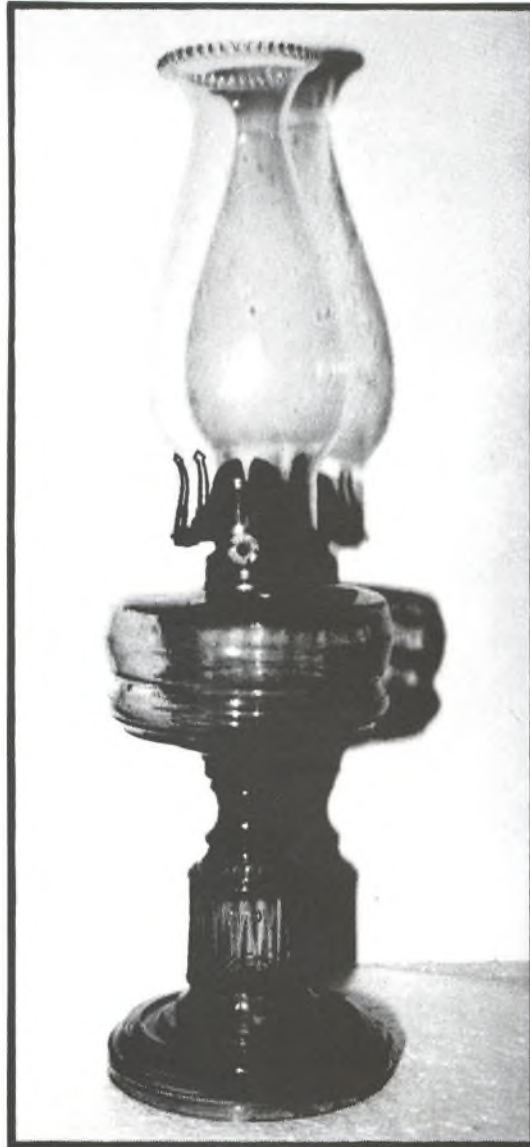

Amber kerosene lamp made by Hemingray.  
Shown 1/3 actual size.  
Photo by John and Carol McDougald  
(Lamp in the collection of Bob Stahr)



marked "HEMINGRAY". This name was registered as a trademark on 29 March 1910, and it was indicated that it had been in use for ten years. (See "The 'Catch-all' Room" page 407 for trademark registration papers.)

### "PETTICOAT"

Samuel Oakman received Letters Patent No. 288,360 on 13 November 1883 for the double petticoat idea. There is evidence that double petticoat insulators had been manufactured by Oakman for some time prior to 1883; but the November 13, 1883, patent included a recess to hold paraffin. (See "The 'Catch-all' Room" page 403.) It appears that Oakman wanted to secure patent rights for the double petticoat, but without the paraffin recess, he couldn't present his invention as new and original. So in an attempt to put the entire design through as a package deal (paraffin recess and double petticoat), both were mentioned in the 1883 patent. Apparently rights to manufacture under that patent were acquired by Brookfield, since their double petticoat insulators were marked with the November 13, 1883,

*Established 1848.*

*Hemingray Glass Co.*  
(INCORPORATED 1870.)

*Manufacturers.*

*Covington, Ky.*

May 15th, 1897

Atlanta Steel and Tin Plate company,  
Atlanta, Indiana.

gentlemen:-

In your shipment to us March 25th, 52 boxes of Tin, there was four boxes of Tin short. These boxes have never come to hand yet. Please have tracer entered and report as soon as possible.

Yours truly,

Hemingray Glass Company.  
*A. Hemingray*

*Factories at  
Muncie, Ind.  
Office at  
Covington, Ky.*

Hemingray letter.  
15 May 1897  
(Courtesy of James Doty)

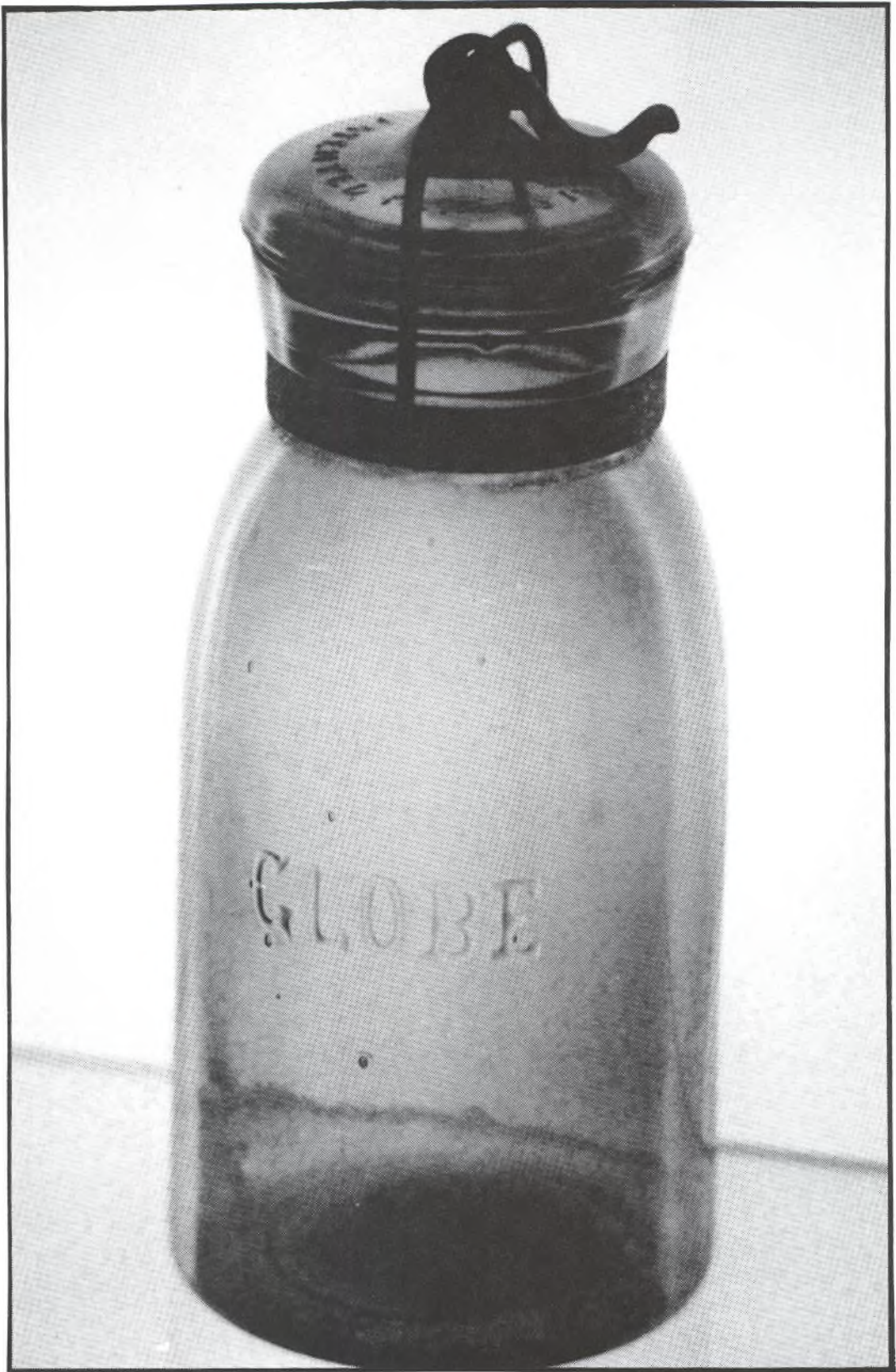

Globe fruit jar, 1 quart, medium amber. Shown approximately actual size. Made at both Covington and Muncie from 1886 to C. 1905.

Photo by Rick Soller

(Jar in the collection of Bob Stahr.)



# GLOBE

The word "GLOBE." Used since February, 1886.

Ad for Globe fruit jars.  
The Official Gazette  
3 Feb 1903  
(Courtesy of Glenn Drummond)

date for many years. (The paraffin recess was never mentioned in other than the November 13 patent, would not have been practical, was never used to any extent, and would have been a nightmare for glassmakers.)

Hemingray believed that he could not be held in violation for making double petticoat insulators so long as they did not have a paraffin recess, and he was correct in thinking that. However, according to a letter from his lawyer, someone may have either accused Hemingray of patent infringement, or, Hemingray was just checking to be certain of his rights. (See "The Mail Room" page 246.)

## "LOWEX"

LOWEX (low expansion, low expense) was Hemingray's answer to Corning's PYREX (the "PYR" referring to "fire". PYREX was first used on cookware that would supposedly withstand oven or surface flame heat without breaking). Hemingray produced LOWEX insulators in the late 1930s and early 1940s (1939-1941). The glass in these insulators was different because of its chemical makeup. LOWEX insulators are made from a borosilicate glass rather than the soda-lime glass used for most insulators. The substitution of borax in the mix causes the glass to require a somewhat higher melting temperature, and was supposed to make it more durable and resistant to etching, ageing, and thermal cracking. However, in actual practice,

# LOWEX

"LOWEX" logo from  
advertising brochure.  
C. 1939

(Courtesy of Mr. N. R. Woodward)

the advantages of borosilicate glass for insulators were somewhat questionable, and its use was discontinued after the start of World War II. In any case, the added expense of production was not justified. Although the LOWEX venture was short-lived, PYREX carrier insulators were in fact used exclusively on AT & T toll lines in America for over 15 years.

The LOWEX data above was submitted by Mr. N. R. Woodward, who states also, "The LOWEX trial was very short-lived. We got into

the war less than three years after it was begun; and I have seen no LOWEX pieces made during the war or after, which stands to reason. They would need a separate tank for the borosilicate glass and by 1942, they were only manufacturing the standard styles from the regular glass, and struggling to keep up, as were all businesses during the war. I think it is likely that the brochure of which you have a copy [which was sent to me by Mr. Woodward and which can be seen on page 372] was the only one ever made for short-lived LOWEX!"

To make a list of those CDs made of LOWEX glass is confusing. Probably all insulators marked "LOWEX" were made of borosilicate glass. A few of the molds were used later with ordinary glass without removing the LOWEX trademark. But there are also other styles of insulators that appear to be made of borosilicate glass. It is possible that these units were made of another formula of borosilicate glass that is not LOWEX, or it is possible that extra LOWEX glass was used up in those molds rather than being wasted. However, Mr. Woodward says that CD 128 CSA and CD 155 Hemingray 45 were made of borosilicate just before the war (1940-1941). Since these were communication styles they were not part of the LOWEX line, and it was not a case of using up extra glass left after a LOWEX run.

Nevertheless, here is a list of those CDs that have been found marked "LOWEX": CD 168 D-510 (the "D" stands for "distribution"), CD 183 Hemingray (Hemi) 71, CD 216 Hemi 661, CD 219 Hemi 660, CD 220 Hemi 670, CD 221 Hemi 680, CD 230 D-512, CD 233.2 D-511 (obviously of LOWEX glass), CD 237 Hemi 72, CD 238 D-514, and CD 252 Hemi 62.

An interesting note; borosilicate glass is usually not accepted at recycling centers because of its higher melting point, and because it makes the glass batch cloudy.

#### DRIP POINTS

Drip points are not an embossing, but they are a beautifully distinct feature of many insulator styles, and were invented by Hemingray. If you would like to learn more about them, and see the patent, please refer to "The 'Catch-all' Room" page 395.

## **PRELIMINARY TO GLASSMAKING**

In this part of the book I will eventually get into the glass-making process, especially as it was done at Hemingray. It's best to keep in mind, however, that we're describing a process that evolved and improved over the 85-year period of Hemingray's history. I will try to mention the differences and changes as we go along.

Although the glassmaking material I have is long and detailed, I figured it would be of interest to anyone wanting to know more about Hemingray. The data was given to me by two former employees of Hemingray, Ern Parkison and John Macken, through letters and phone calls. Additional notes were supplied by Mr. Woodward. I found



PATENT DRIP PETTICOATS.

— ESTABLISHED 1848. —

CATALOGUE OF  
Screw Glass Insulators,  
Battery Jars,  
Electric Light Globes, Etc.

MANUFACTURED BY

HEMINGRAY GLASS CO.

(INCORPORATED.)

General Office: COVINGTON, KY.      Factory: MUNCIE, IND.

MAY 1, 1903.

Company catalog.  
1 May 1903  
Restored by author.  
(Courtesy of Mike Sovereign)

No allowance for breakage. All claims for deductions must be made within FIVE DAYS after receipt of goods. Remittances to be made direct to us in Funds at Par in Cincinnati or New York. No payments to Agents will be accepted unless authorized by our special written instructions.

Established 1870.

# Hemingray Glass Co.

(INCORPORATED 1870.)

Manufacturers.

Factories at  
Muncie, Ind.

Office at  
Covington, Ky.

Covington, Ky. June 18 1903

Sold to Gill Brothers

Terms:

Muncie Ind

1460	#	White Sand	300				219

Hemingray invoice.

18 Jun 1903

Digitally scanned and enhanced by Bill Meier.  
(Courtesy of Ball State Univ., A. M. Bracken Library,  
Archives & Special Collections, and  
Rosella Cartwright)

it fascinating and I'm hoping you will also. However, before reaching that part of my story, I think it would be well to cover a few related subjects first, so that by the time we get to the glassmaking part, you will be familiar with some of the terms mentioned therein.

### CULLET

Those of you unfamiliar with glassmaking, as most of us are, might not know exactly what cullet is and why it is used. "Cullet" is the term used for waste or leftover glass used again in another glassmaking project. The word is related to the French word for "neck" (col), and Webster states that it is "in reference to glass debris at the neck of a bottle in blowing, or scraps of waste glass that can be remelted." Cullet can be of any type of glass; old bottles, window glass, insulators, etc. (The only exception is Pyrex glass, which most recycling operations won't accept these days because that type of glass has a higher melting point, as mentioned earlier.)

Before being remelted, cullet is washed, sorted by color, and



crushed. It is used in all glassworks. It is possible to make glass entirely from cullet, but it is not practical to make it entirely from raw (dry) materials. For some reason cullet is needed to make the mix fuse and blend properly.

Not much cullet was used in the very earliest of the Hemingray insulators. Those old No. 1, 2, and 3 telegraph insulators (with only numbers on them) are of rather uniform aqua, and made from good-quality sand. However, cullet was used extensively at Covington where in their later production, swirls, streaks, and mixed colors resulted. These pieces are highly prized by many collectors today.



Copy of 3-color porcelain Hemingray sign.

On bottom of original sign:

"Nat'l. Enam. Co. Cin. O."

C. 1908

(Courtesy of Timothy Sternke)

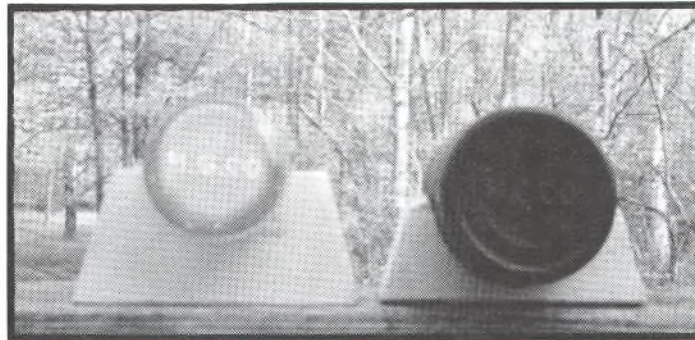

H. G. CO. bottles. Blue aqua, mineral water bottle;  
dark amber, beer bottle. Shown approximately  $\frac{1}{4}$  actual size.  
Made at Covington in the late 1870s or 1880s.  
Photo by John Milek  
(Bottles in the collection of John Milek)



## MOLDS AND PRESSES

Before any glassware could be made, first there had to be molds. These were made of cast iron, and apparently Hemingray made their own molds in their foundry and machine shop at both Covington and Muncie. When the fire occurred at Muncie in June 1892, The Muncie Daily News mentioned that the Hemingray factory had the finest foundry and machine shops, which had no equal in any glasshouse in the west. It also said that they made all of their own molds. So the molds were cast in their foundry, and machined and engraved in their mold shop. (A note here about molds. Hemingray no doubt brought what they had at Covington to Muncie when they made the move. They probably used some at Muncie with no change, while others have added engraving, as the "Dec. 19, 1871" and "May 2, 1893" date on the same insulator. The 1871 patent would have expired by 1893, so old molds is the only explanation for both dates on the same insulator.)

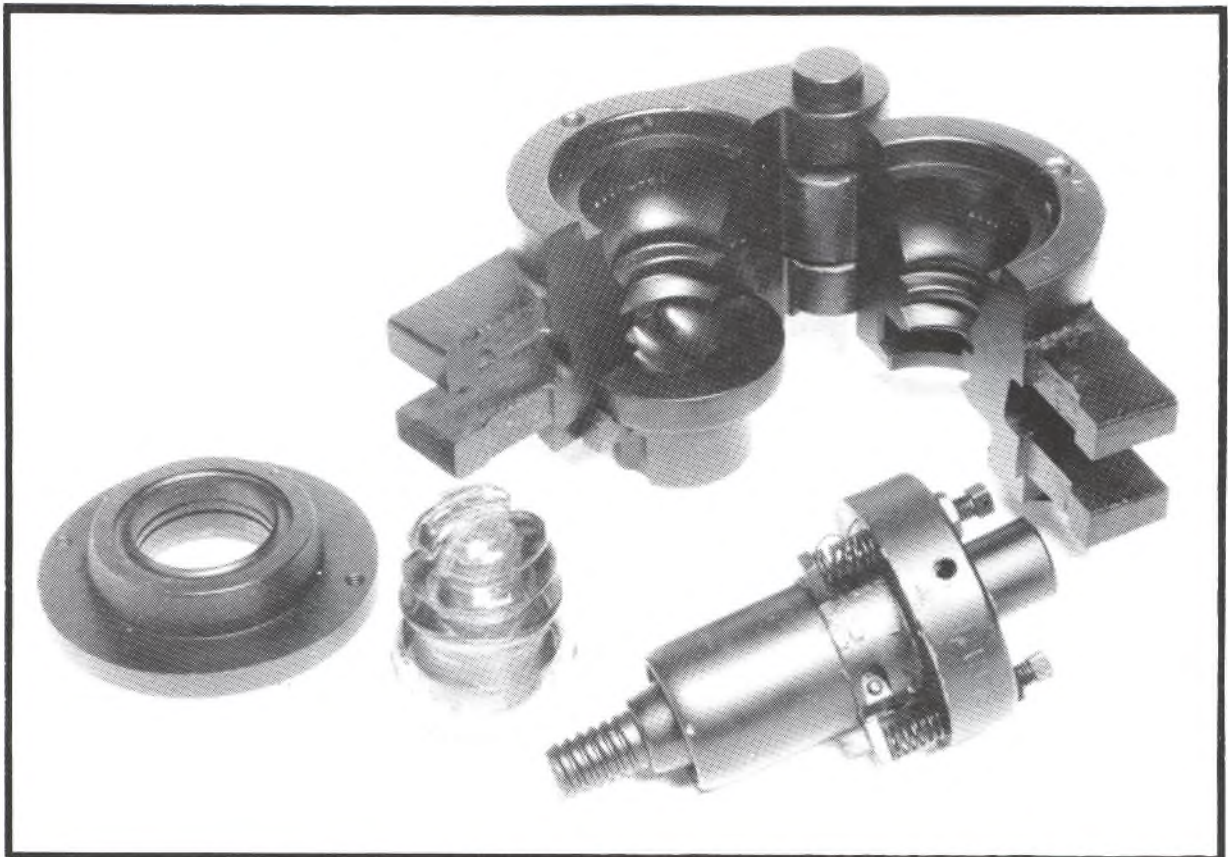

Mold assembly for CD 214 Hemingray 43. From left to right, foreground; plunger assembly support ring, CD 214 insulator, plunger assembly. Background; mold cheeks, hinge pin, base. Embossing can be seen in mold interior, upside down and backward.

Photo in the collection of the American Museum of Glass,  
Wheaton Village, Millville, NJ  
(Courtesy of Donald Wentzel, Richard Wentzel, and Bob Stahr)

# GLASS PRESS

BUILT BY

**The Fischer Foundry Co.,**  
Muriel St., from S. 15th to 16th,  
**PITTSBURGH, PA.**

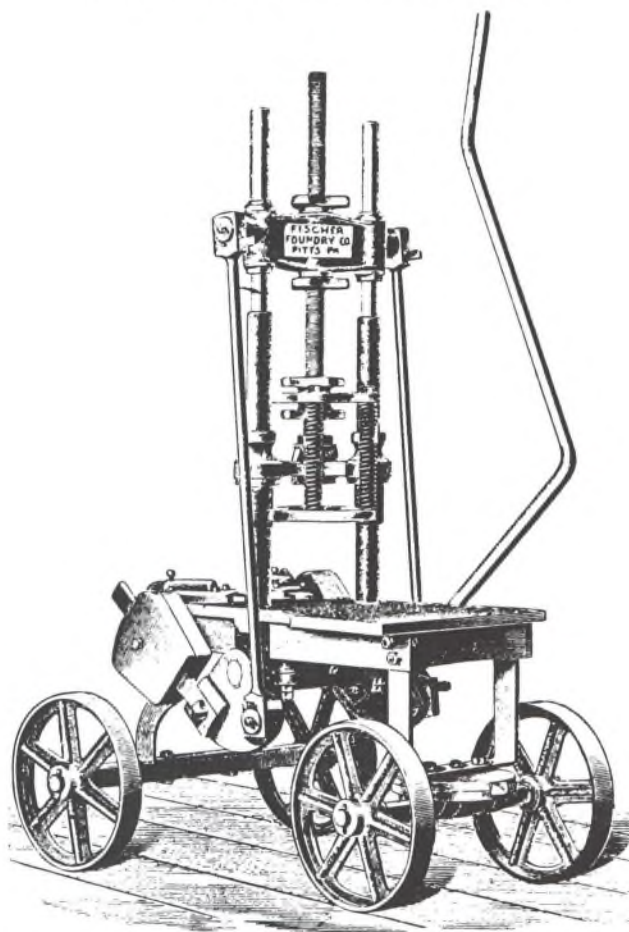

**SIX SIZES—10, 12, 14, 16, 19 AND 22 INCHES  
BETWEEN UPRIGHTS.**

---

**The most modern and complete Press in the market.  
It has no equal.**

---

**WRITE FOR PRICES.**

Glass press likely similar to the ones used by Hemingray.  
(Note patent on the following page.)  
From a small handout.  
C. late 1800s  
(Courtesy of Ray Klingensmith)



R. G. HEMINGRAY & C. HAWK.  
 SCREW PRESS TO FORM INSULATORS.  
 APPLICATION FILED AUG. 9, 1907.

909,595.

Patented Jan. 12, 1909.

3 SHEETS—SHEET 1.

*Fig. 1.*

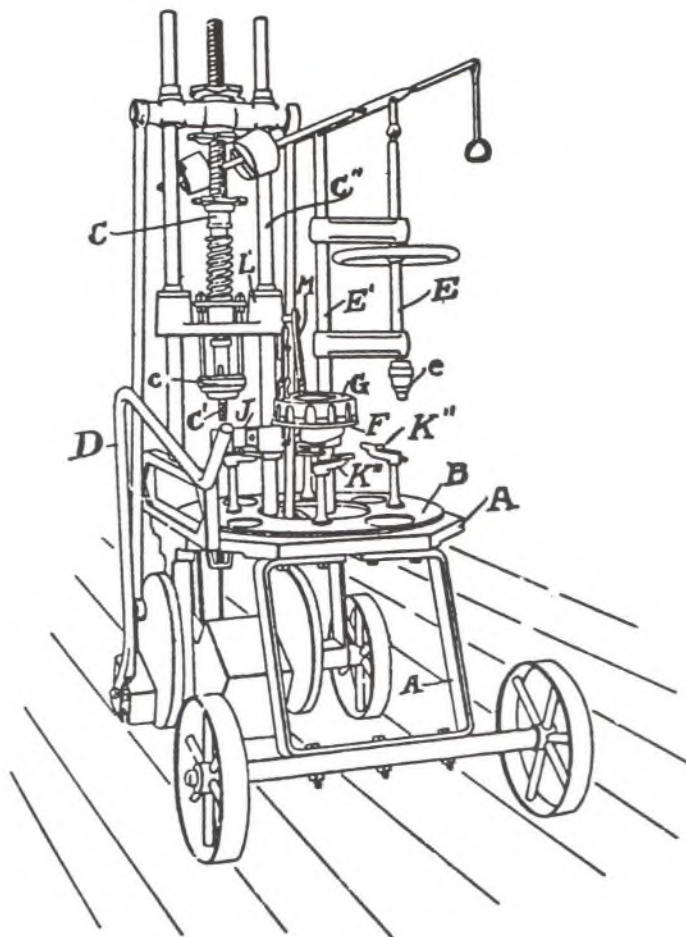

*Witnesses.*  
 Homer Bradford.  
 L. V. Keist.

*Inventors,*  
 Ralph S. Hemingray  
 Charles Hawk  
 by Henry Hehlke  
 Their Attorneys.

Patent for insulator press.  
 12 Jan 1909  
 (Courtesy of Mr. N. R. Woodward)

The insulator press is the whole machine that is used to make insulators. The presses were on wheels so that they could be moved to and from the furnace (feeder) area as needed. They could be set up with different molds to make different styles of insulators (or other glass products.) The mold, into which the glass is deposited to form the insulator, is composed of several parts and fits right into the press.

#### THE FURNACES

Nothing is known about the furnace arrangement at Cincinnati other than the sketch that survives in an old company ad (see page 93.) Excavations were done in 1986 at Covington and the outlines of the various furnaces were uncovered. Apparently there was one

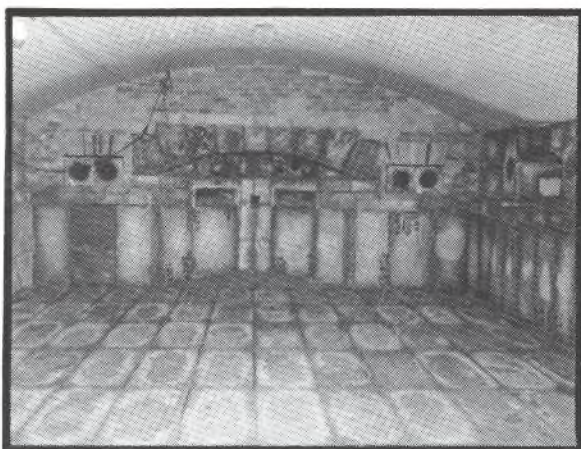

large continuous (24-hour) furnace and a smaller one for small color jobs. But at Muncie the furnaces were huge, the interiors of which were as large as some living rooms. Both "A" and "B" furnaces still existed at Muncie

Interior of "B" furnace  
looking north.  
C. 1930

(Courtesy of Ruth Crawford)

Exterior of "A" furnace  
looking north.  
Mar 1997  
(Courtesy of Bob Stahr)

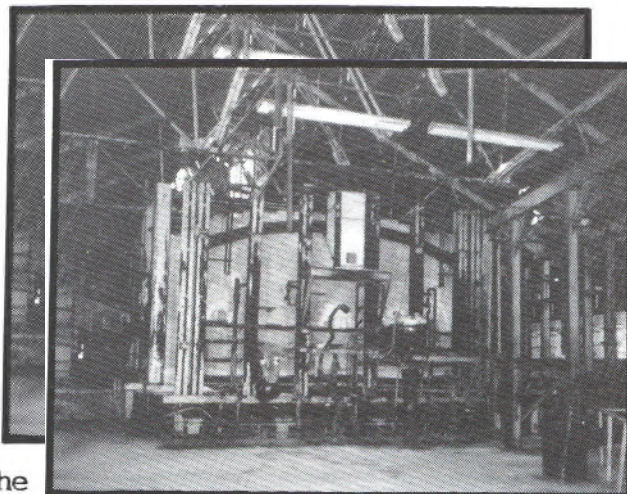

when I was there in May 1981. It was very dark in the building, with no light except for the little bit that filtered in from the windows near the roof. So when I saw "B" furnace, it was mostly in shadow. Although we couldn't go inside the furnace, we saw the pipes which fed the gas to the furnace, and a big iron door. The furnaces ran on gas, and also created the steam with which the other machines (including insulator mold machines) in the factory were run. If memory serves me correctly, the furnace was several feet off the ground on iron stilts. A metal staircase led up to a catwalk that ran just a few feet around the outside. (For an excellent drawing of a furnace like this one, please see Fred Padgett's Dreams of Glass--The Story of William McLaughlin and His Glass Company, pages 73 and 74.) Although it was very dark inside, I remember that the furnace was much taller than a person and rounded on the top



like a small Quonset hut. There was a tarlike substance on the top and sides, and it was covered with dust (which probably wasn't there when the furnace was in use).

Ern Parkison, who was the last man hired by Hemingray in 1931, sent me the following information:

*"A" furnace (tank) was in one building and "B" and "C" tanks in others. "B" tank was the larger, servicing five feeders. "A" tank had but four. On down the drive was "C" tank which was about the size of "A" tank. In later years a much smaller tank, known only as the "dinky", was built still farther down the drive. It had but one feeder and was used mostly for experimental work.*

And this came in from Fred Padgett:

*There were in the early days of coal- and coke-fired furnaces, large round "pots" in which glass was melted and hand-gathered on a blowpipe by the glass blowers. Increased need for production capacity led to the "pot" furnaces becoming "tank" furnaces like your photos...old timers no doubt referred to both "pots" and "tanks" as "pots".*

Since all of the above information was written, much more has been gathered, and many recent historical photos have been taken. So much was sent to me that I'm offering it in "The 'Catch-all' Room". If you would like to learn more about furnaces, especially those at Muncie, please see page 410.

#### COAL

At Covington, and at times in Muncie, coal was the fuel used to heat the furnaces. Photos of the Covington works show the huge piles of coal stacked next to the factory (see next page). Mr. Woodward writes:

*Anthracite coal is "hard" coal, mined in Pennsylvania, West Virginia, etc. Bituminous coal is a few million years newer, is "soft" coal, and does not burn as hot or as clean. It is mined in the West; Wyoming and Montana have big deposits. William Brookfield's father, James Madison Brookfield, is said to be the first to use anthracite coal in his glassworks in Honesdale, Pennsylvania, in the 1850s. Coal used at Covington would be the same kind; they are right next door to endless mines.*

#### GAS

Hemingray moved to Muncie in the late 1880s mainly because of an apparent abundant and cheap supply of natural gas. However, it wasn't the unending supply that everyone thought it would be. By about 1901 it became apparent that the gas was running out, so many



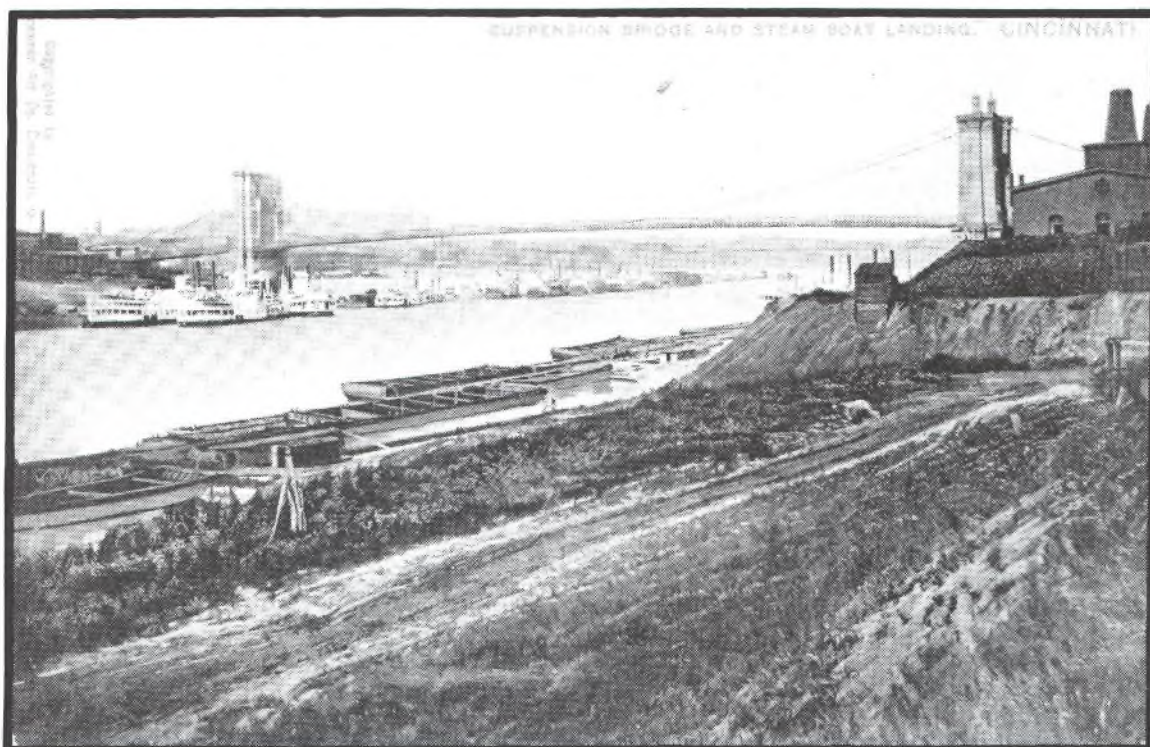

Post card made from photo of suspension bridge showing the Hemingray Glass Co. at right. Note stack of coal. Looking east on Covington side of Ohio River. C. 1868  
(Courtesy of Glenn Drummond)

companies including Hemingray had to search for an alternative fuel source. Over the next few years they eventually went to producer gas which they produced on the property by burning coal.

## **A FEW PRODUCTION NOTES ON THE THREE HEMINGRAY FACTORIES**

Although this section will deal mainly with insulator production at Muncie, glassmaking was more or less the same at the other two factories. As mentioned, one of the big differences was the type of fuel used to heat the furnaces.

When the Cincinnati glassworks began in 1848, this area had great potential for business due to its location and population. With the advent of the telegraph in this area in 1847 and the coming of the railroad soon thereafter, the company of Gray & Hemingray was "in on the ground floor" where the burgeoning industry of insulator production was concerned. During these early years the company made both threadless telegraph, and lightning rod insulators. It is known that the telegraph line built between Cincinnati and Louis-



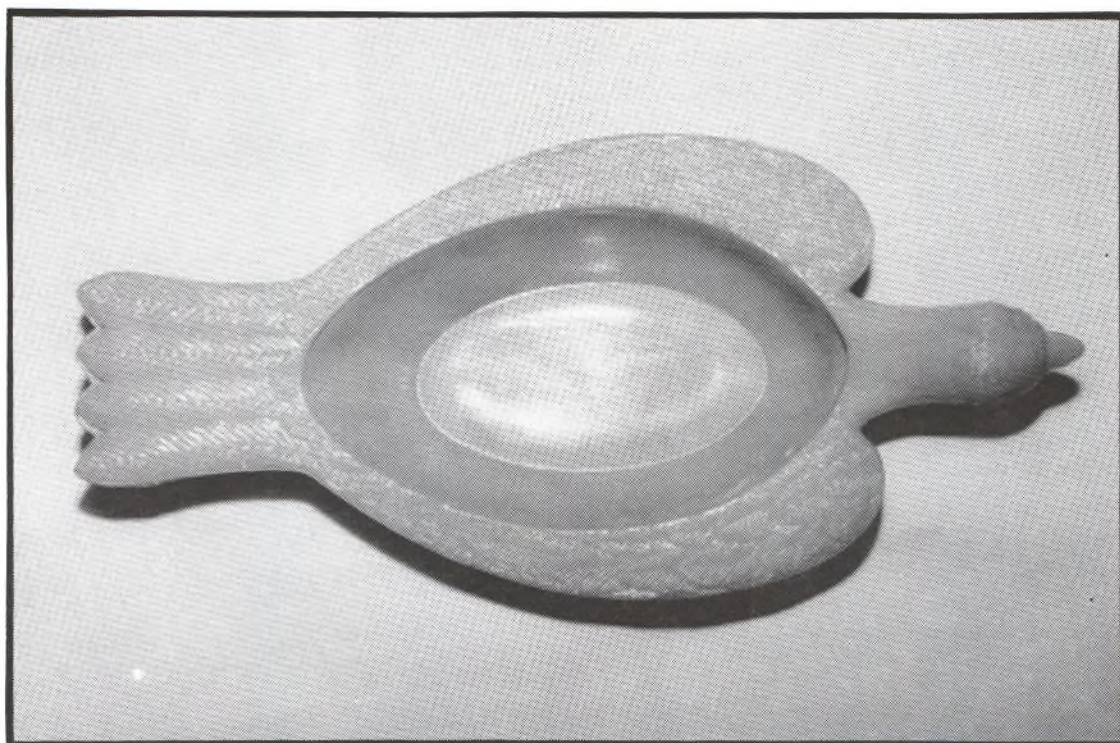

Hemingray bird dish, pink milkglass. Shown approximately  $\frac{1}{2}$  actual size. Dishes known to come in amber, yellow amber, clear, light blue, peacock blue, peacock milkglass, clam broth, pink clam broth, dark pink milkglass, white milkglass (both opaque and opalescent).  
Made at Covington in the late 1870s and early 1880s.

Photo by John McDougald  
(Dish in the collection of Bob Stahr.)

ville used glass blocks. Nothing has been found, however, to suggest that the blocks were made in Cincinnati. While it is probable that the original Spratt lightning rod insulators were made by the Cincinnati Flint Glass Works, a noticeable change in glass characteristics suggests that Gray & Hemingray may have produced the later Spratts, especially after J. H. Weston acquired the Spratt Works.

This book won't list every insulator made by Hemingray or the dates and places of their production. That information is not known by me, so I will leave those details to a future Hemingray writer. However, the year 1869 (at Covington) was significant, as it saw the beginning of the production of threaded insulators by the company; the unembossed CD 127.4 and CD 131.4.

Insulator-making at Hemingray was a huge operation. It is difficult to comprehend the tremendous amounts of raw materials coming into the plant every day, the huge hoppers delivering the materials to the furnaces, the enormous furnaces gobbling up the materials and spitting out insulators by the hundreds, and the trainloads of insulators constantly leaving the plant. In less than 12 days following the fire at Muncie in 1892, The Muncie Daily Times of 30 June states, "Since the fire the Hemingray factory have [sic] turned out two car loads of glass insulators and are still at work on pressed ware..." (Carloads are railroad boxcars, full of insulators.) Production was even heavier later when operations became more mechanized.

**Our new High Potential Insulators will be ready January 1st, 1903.**  
**It will pay you to wait.**

**HEMINGRAY GLASS CO.**

Factories: Muncie, Ind.

COVINGTON, KY.

Company ad.  
The Electrical World and Engineer  
27 Dec 1902  
(Courtesy of Elton Gish)



From a 1904 issue of Telephony we read, "At the present time the claim is made that the Hemingray Glass Co. is not alone the largest establishment of its kind in the world, but that its yearly output and sales are more than those of all other insulator manufacturing industries combined. It manufactures annually many millions of insulators, all of which find a ready market. The factory at Muncie, Indiana, is kept running day and night, but even with the plant working to its outside limit, the company reports that it is behind on its orders. The offices of the concern, at Covington, Kentucky, are a busy hive of industry." It goes on to say that the company, more than any other agency, was particularly successful in producing superior high voltage insulators.

Also in 1904 the Hemingray Glass Company is listed in the Glass Factory Directory as having three continuous tank furnaces, with 18 working rings, and one furnace (most likely this was a pot furnace that was not continuous). A glassmaker told me that a ring refers to the number of hand workers around each tank of glass, and that "continuous" means that the furnaces were kept hot 24 hours, seven days a week (except for the summer break).



## HEMINGRAY

**HIGH EFFICIENCY**      You  
**INSULATORS**      may not  
know it, but it

is a fact that these are the most successful high efficiency insulators yet devised.

**See the Tests on the Petticoat**  
they prevent creeping of moisture. :

**HEMINGRAY GLASS CO., Covington, Ky., and Muncie, Ind.**

Company ad.  
The Electrical World  
23 Dec 1909  
(Courtesy of Elton Gish)

In the 1910 Official Gazette of the United States Patent Office, a description of Hemingray's goods reads, "Electric, Telegraph, Telephone, Cable, Street-Railway, and Floor Insulators and Break-Knobs of Glass". In this same year Hemingray trademarked their name; and by about 1918 insulators had become the chief product of the Muncie plant.



Two-quart Minnehaha refrigerator water bottle, embossed  
"HEMINGRAY" on bottom, ice blue aqua. Embossing reads  
"Minnehaha Spring Water" enclosed in a rope border.

Shown approximately  $\frac{1}{2}$  actual size.

Made at Muncie, 1931-1932.

Photo by Dwayne Anthony  
(Bottle in the collection of Dave Hall)



TRADE MARK  
**HEMINGRAY**  
 REGISTERED.



The biggest success  
 so far achieved by high potential

## Insulators:

*See the tests on the petticoat*

The tests on the petticoat attract water on the outer and inner surfaces into drops, preventing creeping of moisture on insulators and pins.

*The line's complete. Catalog tells all.*

**HEMINGRAY GLASS CO.**  
 General Office: Covington, Ky.      Factory: Muncie, Ind.  
1

Company ad.  
The Electrical World  
 30 Jun 1923  
 (Courtesy of Bob Stahr)

#### WORKING CONDITIONS

Working conditions inside glass factories, especially in the 1800s, were not ideal, but they did improve over the years. In the beginning, glassmaking houses were hot, dusty, noisy places in which to work, and the danger of being injured by burns or other means ran high. Due to the extreme heat, fires were common. The temperature inside often reached and stayed at 130° F. or more. In the early days especially, it was so hot that they had six men on and six off, as frequent trips outside to the well (at Muncie) were necessary so that the men could cool off and catch a breath of fresh air. According to newspaper accounts, Hemingray would shut down the furnaces for two months in the heat of the summer (30 June to 1 September), because they had no adequate means of dissipating the awful heat. At this time inspections could be made to the furnaces and other equipment, and annual repairs done. The workers could rest, and many took vacations or visited relatives during the summer break.

One Muncie resident told me that her grandfather worked for Hemingray starting in 1908, for ten to twelve hours a day, long hard days under hot and uncomfortable conditions. He earned 12¢ an hour, working on the second floor where insulators were put on racks to cool before washing and packing. Although the heat probably remained a plague for glass workers, other working conditions did improve in later years. Safety measures were taken which cut down on injuries to the workers, hours were cut, and wages increased.

According to census records, many of the workers at Hemingray, both at Muncie and Covington, were young people, boys and girls, many of them black. This was a common practice at the time and was not considered abusive.

# THE GLASSMAKING PROCESS AT HEMINGRAY

I'm quite certain that some of the details of glassmaking at Hemingray have been overlooked or omitted here, but not intentionally. Although this process was very patiently explained to me by two former Hemingray employees, my lack of knowledge of the subject and unfamiliarity with it hampered me from fully understanding everything I was being told. But I think the general idea has been conveyed, and I hope you will soon have a better understanding of how glass products, especially insulators, and in particular Hemingray insulators, were manufactured. One fact stands out; no matter how they were made, Hemingray insulators are the loveliest in the world.

Glassmaking at Muncie in the early years was much more difficult than in later times. Most of the hauling of the raw materials from the mixing places to the furnace was done by wheelbarrow. Later, motorized trucks were used. Also, the mixing of ingredients was at first done by hand; later a raw materials silo was built which

**THE STANDARD**

**“HEMINGRAY”**

**ALL WITH THE “PATENT DRIP PETTICOATS.”**

---





**THE HEMINGRAY-GLASS CO.**

Office, Covington, Ky.
Factory, Muncie, Ind.

**ESTABLISHED 1848**

Company ad.  
Telephony  
Oct 1903

(Courtesy of Mike Sovereign,  
Elton Gish, and Bob Stahr)



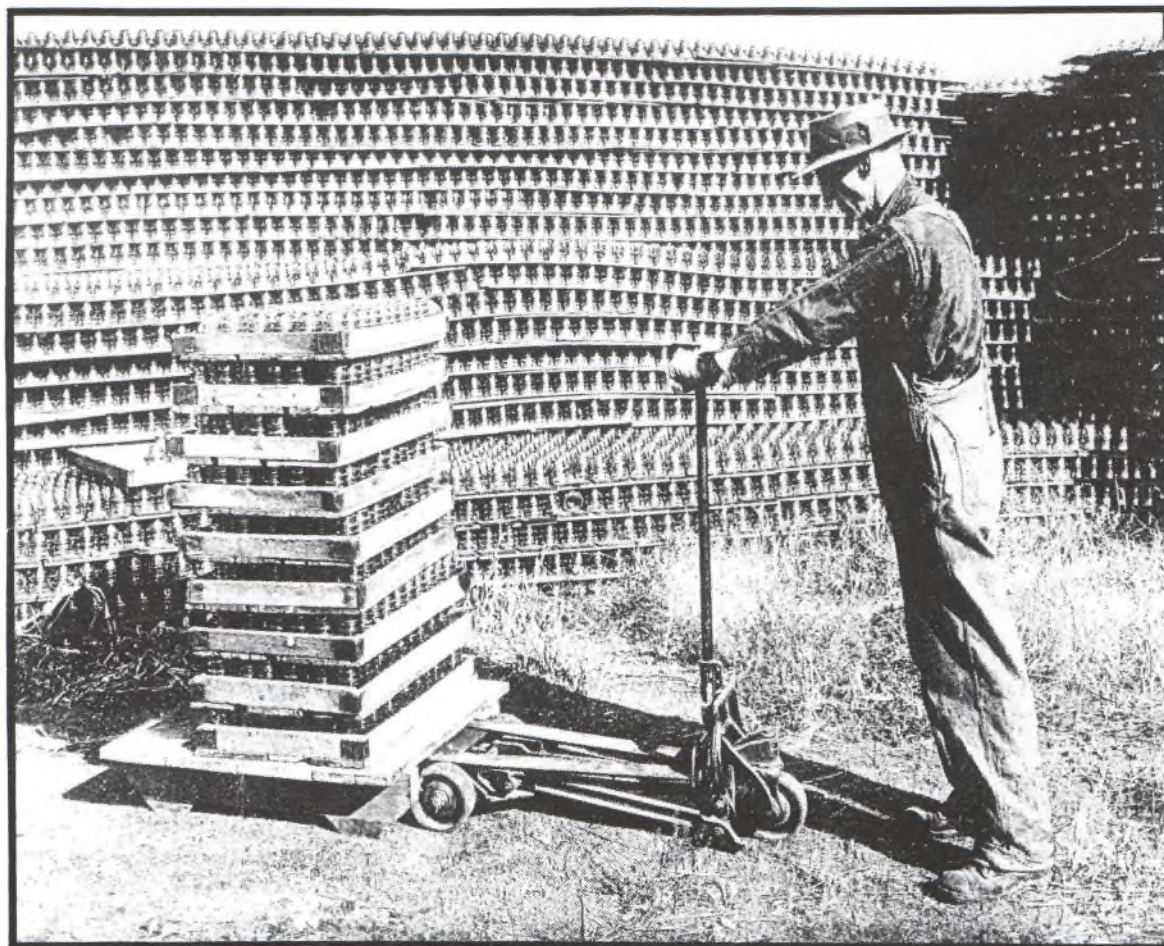

Insulators at Muncie.

4 Nov 1914

(Courtesy of Ball State Univ., A. M. Bracken Library,  
Archives & Special Collections, Sellers Photo Collection)

facilitated the mixing process. These and other details will be discussed at length as the story progresses.

#### INGREDIENTS

To begin a description of the flow of operations in glassmaking, it might be well to start with a list of the ingredients used. Mr. John Macken of Muncie worked at Hemingray from April 1918 until his retirement from Owens-Illinois in October 1965, a career of some 47 years. He spent a long time in a supervisory capacity, his last ten to twelve years in the engineering department. Most of the data on glassmaking was described to me by him, and he was so patient with my ignorance. According to him, the raw materials consisted of silica sand, cullet, raw lime, soda ash, and feldspar. Pearl ashes and lead are additional ingredients mentioned by Sketches & Statistics of Cincinnati in 1851, by Charles Cist. None of the sand was ever purchased from Indiana. (Another source says it came from the vicinity of Michigan City, Indiana, on the southern tip of Lake





This photo was labelled "Hemingray Darkeys" (or Donkeys), more likely the former. This label is certainly politically incorrect today. Many of the children who worked for Hemingray apparently were black. Location unknown.

18 Nov 1914

(Courtesy of Ball State Univ., A. M. Bracken Library, Archives & Special Collections, Sellers Photo Collection)

Michigan. Another source reports that some sand came from Missouri, and lead from Illinois.) Mr. Macken stated that during the days of the green (aqua) insulators, or from about 1900 onward, the sand was purchased from Michigan. It was a very low grade of yellow sand. (He also said that the color was never called "blue" or "aqua" at Muncie, but always "green".) The aqua color was the result of the amount of iron in the sand. This color occurred naturally if no decolorizing agent was added.

In the early days, a long wooden building approximately 40 feet wide ran the length of both "A" and "B" furnace buildings, and was located in front of these buildings. A railroad switch track ran the full length of each side of the building. the car unloading



was done by hand using shovels and wheelbarrows. The preparing of the batches for delivery to the furnaces was also done by manual labor and the use of two-wheeled carts with rubber tires. The preparing of the batches included the measuring, weighing, coloring, and feeding of the raw materials to the delivery carts. As one would imagine, there wasn't the control possible using manual labor in the weighing and mixing of the raw materials. This process became much easier and more control was achieved with the construction of the raw materials silo between 1931 and 1933, shortly before O-I bought Hemingray. This huge silo stored and weighed all the raw materials used in glassmaking. It consisted of six compartments which held the ingredients mentioned earlier. (There is a photo of this silo on page 140.) These materials were individually weighed on automatic scales and then mixed in one of two mixers there, and fed to the metal delivery hoppers (cans or containers). A complete batch of raw materials weighed approximately 1000 to 1100 pounds. The iron hoppers weighed approximately 1000 to 1500 pounds. So the total weight of materials and hopper was approximately 2500 to 2800 pounds. (These hoppers replaced the hauling of batches by wheelbarrow or cart.) The amount of dry batches made each day depended on the total tonnage being pulled out, feeding several forming machines.

#### COLORIZING

It was the chemist's job each day to make up so many small cups of decolorizer for clear flint glass, or colorizer for colored glass. The chemist might add a little or take out a little of something else in order to control the color. The agents and exact formulae used for making special colors, as well as those used for making decolorized glass, would be quite complex, and doubtless varied from time to time. Sand source also comes into the picture, since a low grade of sand cannot be decolorized. Manganese was used as a decolorizer, and later on in the 1930s, selenium was used.

The operator making up the batches of raw materials would put in one cup of decolorizer to every batch delivered to the melting furnace. The purpose of the decolorizer was to hold control of the clear flint glass. The cups were small tin cups about the size of a coffee cup. A bit of sand was put in the cup and mixed with whatever chemical was needed for a certain color and batch. The chemicals were handled in grams. In later years they were located in bins inside the raw materials silo. (I saw these bins when I visited Muncie, but it was too dark to photograph them; instead I photographed the door leading to the inside where the bins were located. See page 140.)

Cullet was also used in batches where color was either required or not important. Hemingray probably used clear cullet for clear glassware, amber for amber glassware, green for green glassware, cobalt for cobalt glassware, etc. Cullet was sorted by color and stored in bins near the raw materials silo. As needed, it was taken to a basement by wheelbarrow (or truck in later times), where it



was washed in cement-lined troughs. The cullet was then crushed and stored in the raw materials silo. Most glass batches, especially at Hemingray, contained some cullet.

Hemingray made very few decolorized insulators prior to 1930 (although the bottles, etc., were probably clear). However, in the early part of this century, CD 162 was listed in a catalog as being available in blue, amber, crystal, and (in one catalog) red. According to a former employee, colorizing agents used were cobalt oxide for blue shades, white arsenic from Mexico and nitrate of soda for making clear glass, which is in most cases a pale aqua or yellow.

In 1931 Western Electric finally said no more aqua glass, period. Whitall Tatum had already gone to the pale yellow selenium glass, and Hemingray reluctantly gave up using the sand from their cheap source in Michigan and went to a higher grade of silica sand that could be made into virtually colorless glass. This resulted in an ice blue color.

In the mid-1930s the ice blue color was changed to clear when the company wanted to produce clearer glass building block; insulators and block came from the same tank. Because more control over color (or the lack of it) was now necessary, they switched to a high grade white sand from Illinois. Some was also bought from Pennsylvania. (Speaking of sand, an 1896 Hemingray Glass Company invoice lists the cost of one ton of white sand at \$2.50.)

#### TO THE FURNACES

Going back to the point where the raw materials were ready for their journey to the furnaces, this was accomplished in earlier times by men pushing wheelbarrows. Later, motorized flatbed trucks were used. Later also, the materials went from the silo to the furnaces instead of from the railroad cars and batch house to the furnaces. One hopper at a time was taken by overhead rail inside the furnace building into the back end of the furnace, where an open scoop fed into the back end into the melting unit. The temperature here ranged from 2300° to 2400° F. (All temperatures given from here on will be Fahrenheit.) Since each ingredient has a different melting point, careful control of melting was necessary to prevent separation of the materials and resulting defects in the glass.

My thanks go to Ern Parkison for the following details. He took up where Mr. Macken left off. The raw materials, called the "raw mix" or the "batch", were melted right inside the furnace in a "pot" perhaps 20 feet by 40 feet and four feet deep. The batch was charged in at the rear by hand. When the melt reached a certain level, the molten glass overflowed into the feeders which were long narrow troughs with an orifice at the outer end which allowed the glass to drop out, either to be wasted or to be used in the forming machines. The waste glass was cullet, and was often remelted and reused.



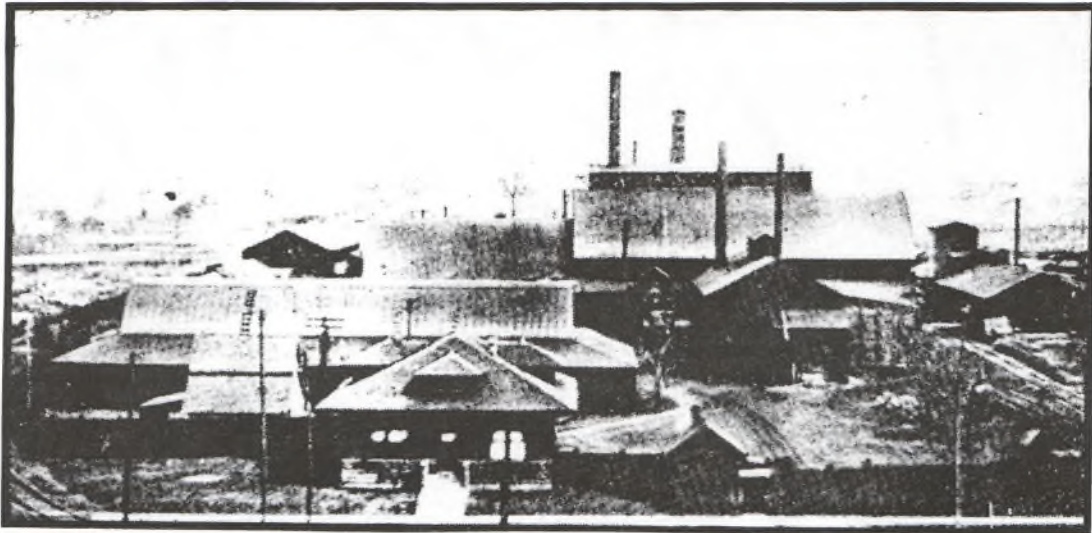

The Muncie factory.  
A Souvenir Booklet of Muncie, Indiana,  
by The Press and Printing Committee of the  
Muncie Commercial Club  
C. 1915  
(Courtesy of Ball State Univ., A. M. Bracken Library,  
Archives & Special Collections)

#### INTO THE MOLD

The part of the system that delivered the glass to the press and mold was called the "feeder". Although at this point the glass was not molded in the sense that it was in its final shape, it was molded into the form of what was called a "gob", or tube of glass in a plastic state. It was at about 1700<sup>o</sup>, and was a few inches in diameter. In the early days the gob was measured and cut by hand and guesswork for dropping into the mold. A skilled worker was able to judge the exact amount of glass needed for each type of insulator or other glass product, then measure it and cut it, usually with a big scissors. (He was called a "shearboy".) In later years, the gob was weighed and cut by automatic feeders. (See an O-I 1954 job history on page 441.) Too little glass resulted in the underpours we've all seen; and when the gob was too cool, or not hot enough, or when the mold was too cool, the gob would bounce into the mold, creating the ghosting effect seen above the embossing on some pieces. (This ghosting or double strike usually appears above the embossing, because insulators are made upside down.)

If insulator production was halted for a time, the molds would cool off. In order to prevent ghosting, when they returned to production, the molds had to be heated up again. One way of doing this was to fill the mold several times with a gob, but the plunger was not used. This created the solid pours sometimes found in glasshouse

## HOW ARMSTRONG'S GLASS INSULATORS ARE MADE

Sand, limestone, soda ash, alumina, borax, magnesia, barium, selenium, cullet—these are the raw materials that are combined in measured quantities to give Armstrong's Glass Insulators strength and weather resistance.

But blending these granular minerals is only the first step. Next, these minerals must be transformed into homogeneous molten glass in huge furnaces. Since each ingredient has a different melting point, careful control of melting is necessary to prevent separation of the materials and resulting defects in the glass.

When melting is complete a measured gob of molten glass is fed into the automatic insulator machines. Just what happens inside these machines is sketched at the right. After a carefully timed interval during which the still red-hot insulator hardens, mechanical fingers remove the insulator from the mold and place it on the conveyor that carries it through the long annealing oven.

In this final step, precise automatic devices control insulator temperature and prevent undesirable stresses from forming. Cooled insulators emerge at the inspection stations where they are individually examined and gauged.

1 The molten gob of glass plunges into the polished mold that provides Armstrong's Glass Insulators with their smooth surface.

2 The plunger moves into position forming the pinhole and petticoat. Seconds later after the glass has hardened, the mold opens and the insulator moves on to the annealing oven.

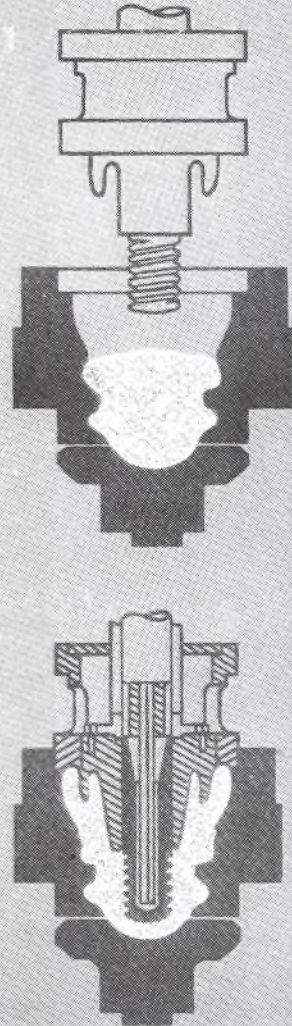

Page 3 from an Armstrong's 8-page catalog,  
showing how glass insulators are made.

1950

(Courtesy of Mr. N. R. Woodward)



dumps and which are sought after by many collectors. But the molds sometimes didn't get heated enough, and insulators are found with ghost embossing.

While the early insulators were made one at a time on a hand press by a crew of several men (called a "shop"), the latest ones were made on fully automatic, continuous-motion presses that carried eight or more molds. On these, virtually all of the operation is entirely automated.

#### OUT OF THE MOLD

The insulators were removed from the molds after only a few seconds. The division between the mold cheeks and the collar and base rim was made at the outer edge of the skirt. After the glass had set in the mold, the mandrel or plunger was removed first. This was done by hand in early years, and by machine later. As the mandrel was unscrewed from the glass, the collar and base rim was lifted straight up in the same operation and set aside or turned into a horizontal position, out of the way. Seconds later the mold cheeks were separated (opened like doors) and the insulator removed. All of this may have taken only a minute; perhaps just seconds. "Take-out boys", as they were called, used forks to pick the insulators out from the hot molds just after they had been pressed and the molds opened out. (In later times, mechanical fingers removed the insulators from the mold.) When the finished insulator came out of the mold it was still red hot at approximately 1050°. According to a letter written in 1953 and sent to me by Glenn Drummond from a woman whose father had worked at Hemingray probably in the 1870s, "...glass blowers were paid so much per day for their work and out of that amount they hired and paid boys of their own choosing to help in whatever way was needed." Many of these were the "take-out boys".

#### TO THE ANNEALING LEHR

From here the insulators were placed on a wire mesh rack six to eight at a time. Besides forks, heavy gloves were sometimes used. These racks were pulled by conveyer belt to the annealing lehr (pronounced "lair") or kiln. (All glass must go through an annealing lehr.) This lehr, or slow-cooling heat-treat oven (sometimes also called a "tempering oven" and often spelled "leer"), was about 110 feet long. It was a brick and metal unit very close to the furnace, carrying a 12-foot-wide continuously-moving conveyer belt. As the table holding the molds rotates, and as each mold in turn opens, the fingers that pick up the insulator turn it over right-side-up and set it on the belt where it immediately passes between flaming gas jets and into the lehr, in only inches of space and remaining red hot, cooling only slightly between pressing and entering the lehr. In early days when all was done by hand, the take-out boys must have worked very fast to accomplish the same results. (Some of the big insulators stayed in the lehr for quite some time. Old-timers say that many of the large insulators were broken by careless workers when handling and packing them.)



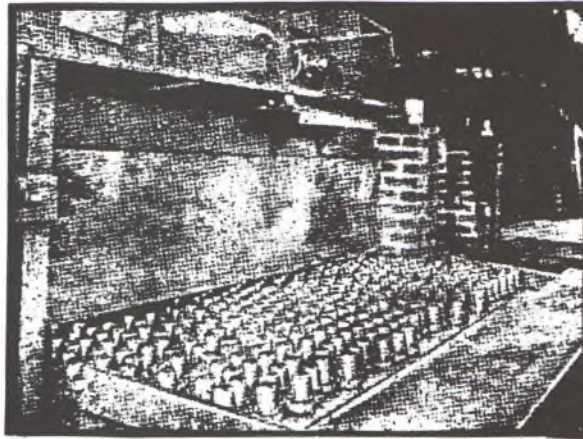

Insulators coming out of the lehr at Muncie.

From a company ad.  
(Restored by author)

The Muncie Star  
25 Sep 1927

(Courtesy of Rosella Cartwright,  
the Muncie Public Library, and Bob Stahr)

Insulators entered the lehr at about 1000<sup>o</sup>, then gradually cooled down to room temperature (in divided sections each at a cooler temperature) by the time they reached the back end of the lehr. Here they passed through the inspection department, and were taken by conveyer belt to the second floor where they were put on wire racks to cool. (See photo on next page) Heavy gloves were used for this operation. After they were cooled, they were washed in long cement troughs to remove factory grime (often the same troughs used at times to wash cullet) and packed in barrels for shipping. It was also at this time that, especially in the early years, the mold or shop letters were checked so that each shop could be paid according to their total output.

#### INSPECTION

Before shipping, the cooled insulators were inspected not only by the manufacturer but by the purchaser. In the late 1800s the making of insulators certainly didn't demand the controls required of bottles, jars, lamps, and so forth. But Hemingray insulators were good enough that purchasers were pleased. But later on, even though glass manufacturers usually strived for good-quality products, purchasers would issue specifications and drawings with measurements for insulators to glasshouses; and over time, they would tighten up those specs. Purchasers would also make inspections using gauges. Here's a quote from a spec for standard, pony, and transposition insulators, dated 24 May 1907:

*The quality of the materials used and the methods of manufacture, handling and shipment shall be such as to ensure for the finished insulators the properties and finish called for in these specifications. The manufacturer*



## Inspection

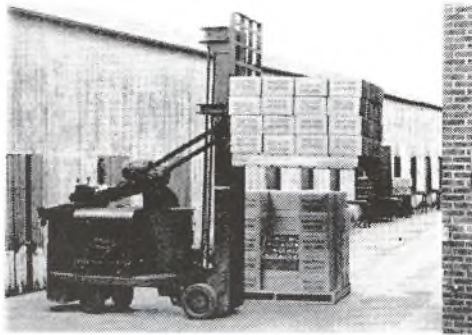

In addition to careful quality control of each batch, Hemingray standards include a careful and individual visual inspection by trained people. After this final check-up, the insulators are packed in sturdy cartons.

All Hemingray designs are warehoused, in cartons, in a sufficient quantity to meet—in the shortest possible time—the emergency replacement needs of Hemingray users.

Hemingray is no "fair-weather" supply source. When emergencies occur, Hemingray insulators are available for immediate shipment.

Inspecting CD 122s (Hemingray 17s with knurled base rim)  
at Muncie.

From a post war catalog.

C. 1946

(Courtesy of Mr. N. R. Woodward)



*must make sure that all material and work is in accordance with the specifications before the insulators are delivered. The Western Electric Company is to have the right to make such inspections and tests as it may desire of the materials and of the insulators at any stage of the manufacture, such inspections not to include inspection of the processes of manufacture. The inspector of the Western Electric Company shall have the power to reject any material or insulator which fails to satisfy the requirements of these specifications. Inspection shall not, however, relieve the manufacturer from the obligation of furnishing satisfactory material and sound, reliable work. Any unfaithful work or failure to satisfy the requirements of these specifications that may be discovered by the telephone company on or before the receipt of the finished insulators shall be corrected immediately upon the requirement of the telephone company, notwithstanding that it may have been overlooked by the inspector.*

*Where maximum and minimum dimensions are shown the dimensions shall be within the limits specified. Where limits are not shown the dimensions shall be approximate... All material and workmanship unless otherwise specified shall be of the best grade...The insulators shall have a finish in accordance with the best commercial practice ensuring, as far as possible, freedom from flaws, cracks, blow holes, sharp edges and other defects. C. E. Scribner, Chief Engineer.*

According to additional information in these specs, size was to be uniform within each design. There were visual inspections made as well as actual measurements taken. The threads were checked with a full-sized threaded steel pin (see next page). They were to be only so far from the crown of the insulator, taking at least two complete revolutions to release the insulator from the gauge, be smooth and of uniform pitch, well-centered within the insulator, and the gauge could not touch the inner surface of the petticoat. Every insulator was not checked; ten out of 100, 15 out of 1,000, etc. Of the amount checked, very few could be defective if the whole group was to be accepted. (The reason I went into all of this is to show the reader just what Hemingray and other insulator-making establishments were up against.)

The foregoing represents only a portion of the specifications for just three styles! In addition, at intervals, Western Electric would tighten up their specs even between purchase years for the same insulator. Also, each year Western Electric would increase the effectiveness of the inspection program, but they would run a draft of the new version past the manufacturers to sound them out on consequential cost increases. This did lead to more uniform dimensions, color, and embossing styles as the years passed. But inspection was a bone of contention between both Brookfield and Hemingray



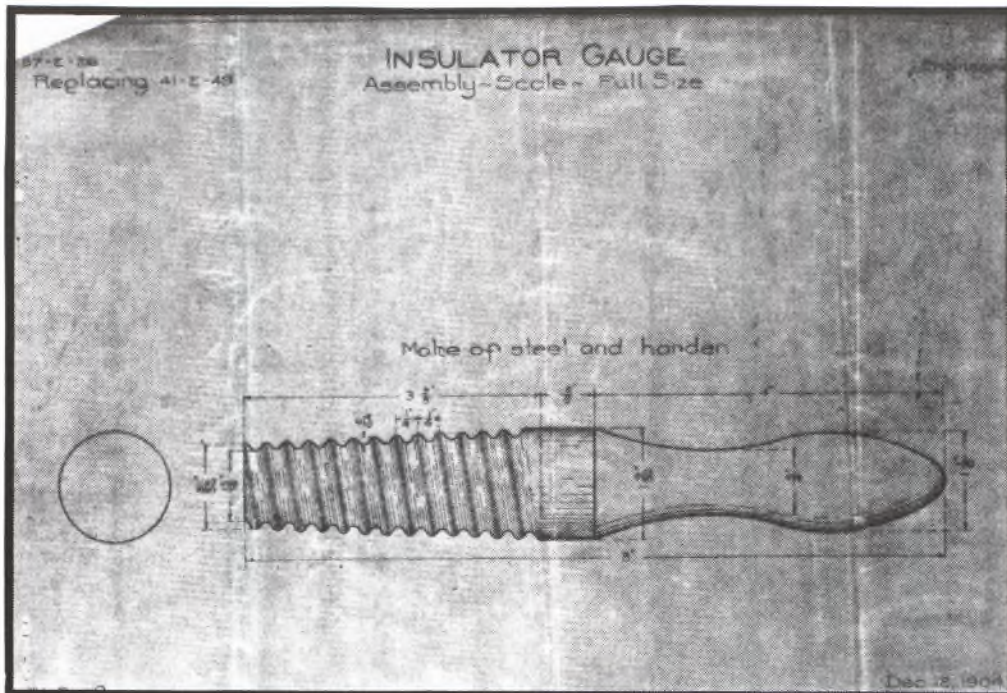

Drawing of gauge used to test insulators.  
From Hemingray line material specifications.

12 Dec 1904

(Courtesy of Glenn Drummond)

and Western Electric for many years. In a letter from Mr. Woodward, he states:

*As for the specifications of the buyers, yes, they did play a major role. Even way back in Brookfield days, I recall being told by William L. Brookfield that his father would be a nervous wreck for days after the people from Western Electric visited to negotiate for the next year's purchase of insulators. Their quality requirements were increasingly stringent, even then: and of course they wanted to buy as inexpensively as possible! And being a customer without whom the business could not survive, Henry Brookfield was in a corner.*

TO WORK

Of course, following a passing inspection, the insulators were packed and shipped to various locations and put in service. Not much care was given to them in the packing process. They were thrown into barrels with little or no regard for drip points or other things that would later appeal to collectors if maintained in mint condition. Many insulators were broken, chipped, removed, replaced, stolen, and "acquired"; and many of these millions of insulators eventually found their way into collections.



# SOME LOVELY

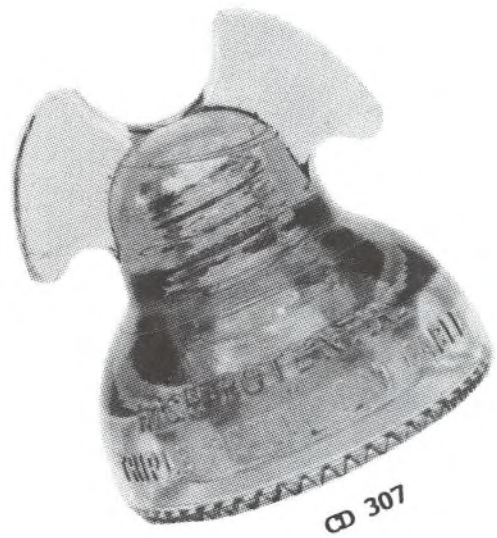
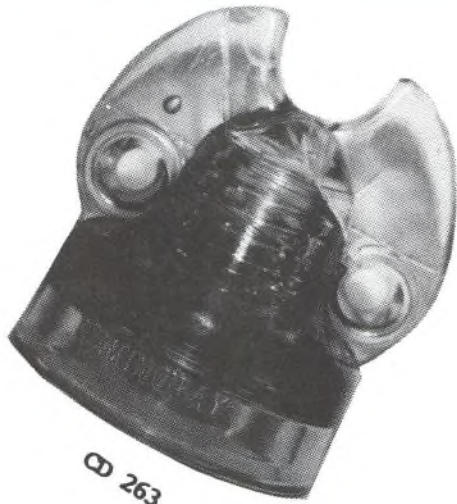

(Photos on these two pages courtesy of



# HEMINGRAY INSULATORS



CD 152

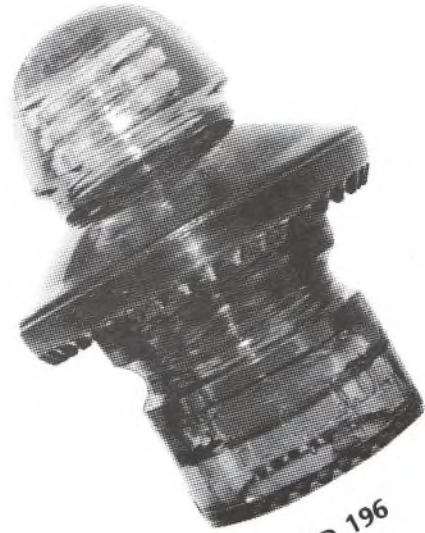

CD 196



CD 106



CD 213



CD 302

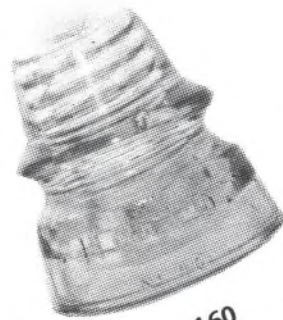

CD 160

John and Carol McDougald)



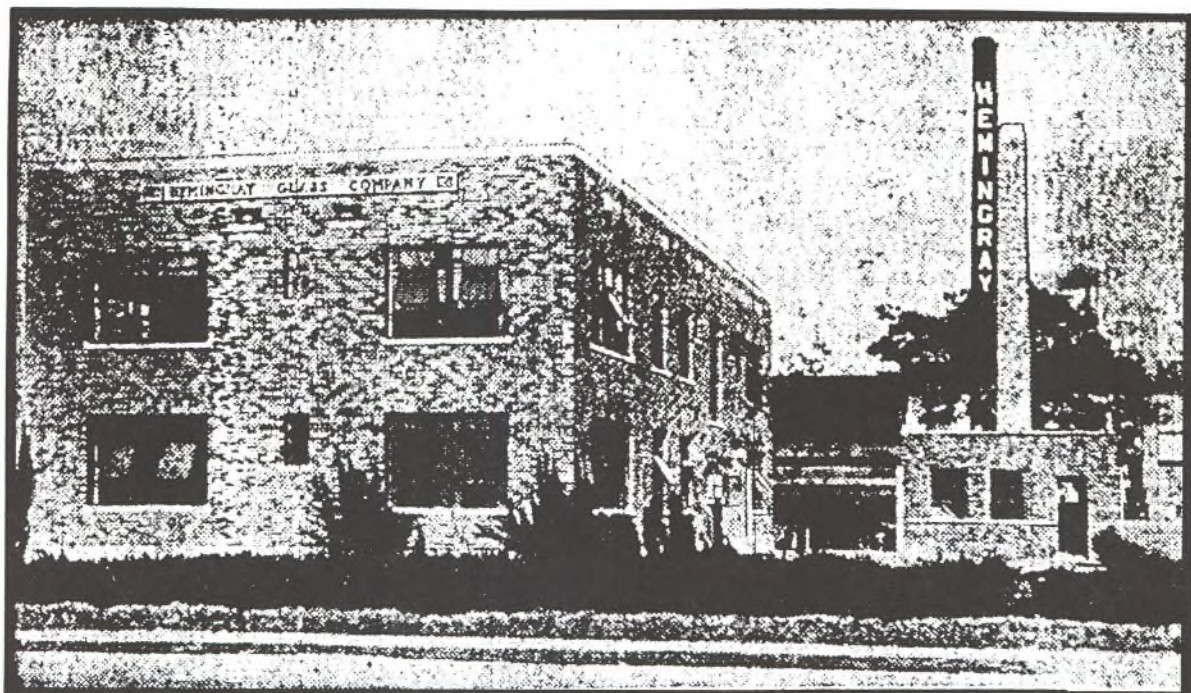

Close-up of Muncie factory (office building in front).

The Muncie Evening Press

27 Sep 1927

(Courtesy of Rosella Cartwright)

## **AND FINALLY . . .**

As mentioned at the beginning of Part III, Hemingray produced a huge variety of items, especially in its earlier years. Later on, as insulators became their main product, they produced millions of them in many styles and colors, and the name "Hemingray" became synonymous in the industry with quality. Even today, whether a person buys, sells, trades, installs, removes, collects, or writes about insulators, the name "Hemingray" will soon surface.

The Hemingrays themselves were hard-working, honest in their business dealings, and well-liked in every community in which they lived and worked. They were known for their generosity, their participation in civic duties, and for their sunny dispositions. They were good to their employees and fair with them, and by all accounts, well-thought-of by them. Upon their deaths, the Hemingrays were sincerely mourned by family, friends, and employees; the ultimate indication of how they lived their lives.



A 1921 Hemingray catalog, when listing the requirements of good insulators, states that their glass insulators have met them all, having passed "the only real test of any product, years of satisfactory service." At the time that was written, Hemingray had been in business for some 73 years, making insulators for most of that time. Could they have known then that 76 years later, in 1997, their insulators would still be in service in some places, giving satisfactory service even today? I think they would have known. Yes, their beautiful insulators are still enduring--some as workers, and many as retirees in collections the world over. Truly the name "Hemingray" is here to stay.

TRADE MARK  
**STANDARD HEMINGRAY INSULATORS**  
 REGISTERED.

## Glass Insulators

*For Every Purpose*

**Central Stations - Telephone and Telegraph - Steam and Electric Railroads - Contractors**

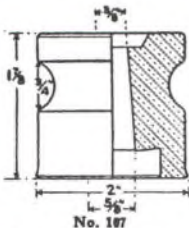

No. 107

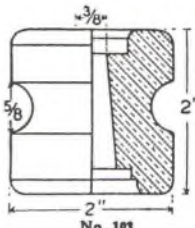

No. 103



**No. 23**  
 St. Ry.  
 4,400 volts



**No. 19**  
 Cen. Sta.  
 4,400 volts



**No. 42**  
 Tel. & Tel.  
 4,400 volts



**No. 71**  
 10,000 volts



**No. 72**  
 11,000 volts

*Specify HEMINGRAY. Insure yourself of Service—Economy—Satisfaction.*

**HEMINGRAY GLASS COMPANY**  
 Est. 1848 Inc. 1870  
 MUNCIE INDIANA

TRADE MARK  
**STANDARD HEMINGRAY INSULATORS**  
 REGISTERED.

The NEW GLASS INSULATOR  
 for Power Lines  
 Made in 3 sizes  
 No. 23—2,300 to 6,600 v.  
 No. 66—6,600 to 8,800 v.  
 No. 88—8,800 to 15,000 v.

Descriptive Literature and Samples Upon Request

Company ad.  
EMF Electrical Yearbook  
 1923  
 (Courtesy of Elton Gish)

TRADE MARK  
**STANDARD HEMINGRAY INSULATORS**  
 REGISTERED.





# THE FAMILY TREE ROOM



CD 257







## A FEW NOTES ABOUT THE FAMILY TREE ROOM

The descendants for each family head will follow right after his name in the order of their birth. So each family head will appear until that particular line ends, or ends as far as we've been able to determine at this time. Also, each person has been given a number for easy reference. This number will correspond with the number in front of their name under "Hemingray People", where I've written small biographies for them.

I haven't typed the word "cemetery" under "Burial Place" on the genealogical charts; that can be assumed. I've just typed the name of the cemetery. Example: Allegheny Cemetery will be typed as "Allegheny", etc.

The Shinkle family seems to have had a penchant for reusing family first names. They might have been able to tell everyone apart at the time, but I got thoroughly confused. So I've put Roman numerals (I, II, III) after some of the names, which might help. These numerals were not part of their names originally.

I haven't guessed at or assumed any statistics. What you see here is just what has been documented. A "B", "D", or "M" at the top of a column indicates that I have a copy of a birth, death, or marriage certificate for that person.

"C." means "Circa" or "approximately".

I owe most of the information in "The Family Tree Room" to Glenn Drummond, who spent countless hours researching this data, and I thank him for sharing it with me and my readers. Also, he designed the genealogy charts to which I made a few small changes. I also thank Lynn McCarthy for some of what you see here. What these two people didn't find was found by myself.



GENEALOGY CHART NUMBERS FOR THOSE ON CHARTS AND IN TEXT

- |                                     |                                     |
|-------------------------------------|-------------------------------------|
| #1 William Hemingray                | #46 Kate D. Shinkle                 |
| #2 Mariah Barlow (Hemingray)        | #47 Bradford Shinkle, Jr. (II)      |
| #3 George Hemingray                 | #48 Moses Swasey                    |
| #4 William Hemingray, Jr.           | #49 Maria R. Pack (Swasey)          |
| #5 Harriett (Hemingray)             | #50 William H. Swasey               |
| #6 Georgeanna Hemingray             | #51 Ella M. Swasey                  |
| #7 Ann Johnson (Hemingray)          | #52 Edward D. Swasey                |
| #8 Catherine Hemingray (Horner)     | #53 Mary E. Swasey (Long)           |
| #9 Samuel J. Hemingray              | #54 Jane P. Matthews (Hemingray)    |
| #10 Robert Hemingray                | #55 Llewellyn M. Hemingray          |
| #11 Reuben Hemingray                | #56 M. Carroll Hemingray (McAbee)   |
| #12 Joseph C. Hemingray             | #57 Philip W. McAbee                |
| #13 Mary J. Hemingray (Evans)       | #58 Ralph H. McAbee                 |
| #14 Charles Horner, Jr.             | #59 Eva Hollinger (Hemingray)       |
| #15 Ann E. Horner                   | #60 Nannie Timberlake (Hemingray)   |
| #16 Robert H. Horner                | #61 Robert C. Hemingray, Jr.        |
| #17 Mary A. Horner                  | #62 Conway T. Hemingray             |
| #18 Catherine E. Horner             | #63 Susan A. Hemingray (Starr)      |
| #19 Charles M. Horner               | #64 Clara Keck (Hemingray)          |
| #20 Harriet B. Horner               | #65 Caroline (Hemingray)            |
| #21 William C. Horner               | #66 Reuben P. Hemingray             |
| #22 Calantha Horner                 | #67 Robert B. Hemingray             |
| #23 Ann (Hemingray)                 | #68 William B. Hemingray            |
| #24 Samuel J. Hemingray             | #69 Maria G. Hawn (Hemingray)       |
| #25 Henrietta M. Hemingray          | #70 Reuben P. Hemingray             |
| #26 Camilla L. Hemingray            | #71 Lillian K. Hemingray (Chambers) |
| #27 Mary A. Carroll (Hemingray)     | #72 Lida Blacker (Hemingray)        |
| #28 Camilla Hemingray (Felix)       | #73 Charles W. Chambers             |
| #29 Anna J. Hemingray (Shinkle)     | #74 Reubin H. Chambers              |
| #30 Mary Ann C. Hemingray (Shinkle) | #75 Gertrude L. Chambers (Donnelly) |
| #31 Catherine Hemingray (Swasey)    | #76 Charles W. Chambers, Jr.        |
| #32 Ralph G. Hemingray              | #77 Richard G. Evans                |
| #33 Robert C. Hemingray, Jr.        | #78 Richard G. Evans                |
| #34 Daniel C. Hemingray             | #79 Edgar W. Evans                  |
| #35 "Little Willie" Hemingray       | #80 Ralph Gray                      |
| #36 William H. Felix                | #81 Ann Friar (Gray)                |
| #37 William H. Felix, Jr.           | #82 Anthony Gray                    |
| #38 Annie B. Felix                  | #83 Susan Carroll (Gray)            |
| #39 Amos C. Shinkle (I)             | #84 Elizabeth Gray                  |
| #40 Sarah J. Hughes (Shinkle)       | #85 John C. Gray                    |
| #41 Bradford Shinkle (I)            | #86 Anna Gray                       |
| #42 Camilla Shinkle (Cross)         | #87 Catherine Gray                  |
| #43 Amos C. Shinkle (II)            | #88 Ralph Gray?                     |
| #44 Frances Hinkle (Shinkle)        | #89 James L. Foley                  |
| #45 Amos C. Shinkle, Jr. (III)      | #90 Juliet Barnes (Foley)           |



THE HEMINGRAY FAMILY TREE

- #1 William Hemingray/#2 Mariah Barlow
  - #3 George Hemingray/#5 Harriett
  - #6 Georgeanna Hemingray
  - #4 William Hemingray, Jr.
- #1 William Hemingray/#7 Ann Johnson
  - #8 Catherine Hemingray/#14 Charles Horner, Jr.
    - #15 Ann E. Horner
    - #16 Robert H. Horner
    - #17 Mary A. Horner
    - #18 Catherine E. Horner
    - #19 Charles M. Horner
    - #20 Harriet B. Horner
    - #21 William C. Horner
    - #22 Calantha Horner
  - #9 Samuel J. Hemingray/#23 Ann
    - #24 Samuel J. Hemingray
    - #25 Henrietta M. Hemingray
    - #26 Camilla L. Hemingray
  - #10 Robert Hemingray/#27 Mary Anne Carroll
    - #28 Camilla Hemingray/#36 William H. Felix
      - #37 William H. Felix, Jr.
      - #38 Annie B. Felix
    - #29 Anna Johnson Hemingray/#41 Bradford Shinkle (I)
      - #42 Camilla Shinkle/Dr. Frank B. Cross
      - #43 Amos C. Shinkle (II)/#44 Frances Hinkle
        - #45 Amos C. Shinkle, Jr. (III)
        - #46 Kate D. Shinkle
    - #30 Mary Ann Carroll Hemingray/#41 Bradford Shinkle (I)
      - #47 Bradford Shinkle, Jr. (II)
    - #31 Catherine Hemingray/#52 Edward D. Swasey
      - #53 Mary E. Swasey/Long
    - #32 Ralph G. Hemingray/#54 Jane P. Matthews
      - #55 Llewellyn M. Hemingray
      - #56 Mintie Carroll Hemingray/#57 Philip W. McAbee
        - #58 Ralph H. McAbee
    - #32 Ralph G. Hemingray/#59 Eva Hollinger
    - #33 Robert C. Hemingray/#60 Nannie Timberlake
      - #61 Robert C. Hemingray, Jr.
      - #62 Conway T. Hemingray
      - #63 Susan A. Hemingray/Shunim? Starr
    - #34 Daniel C. Hemingray/#64 Clara Keck
  - #11 Reuben Hemingray/#65 Caroline
    - #66 Reuben P. Hemingray
    - #67 Robert B. Hemingray
    - #68 William B. Hemingray
  - #12 Joseph C. Hemingray/#69 Maria G. Hawn
    - #70 Reuben P. Hemingray/#72 Lida Blacker
    - #71 Lillian K. Hemingray/#73 Charles W. Chambers
      - #74 Reubin H. Chambers
      - #75 Gertrude L. Chambers/James B. Donnelly
      - #76 Charles W. Chambers, Jr.
  - #13 Mary Jane Hemingray/#77 Richard G. Evans
    - #78 Richard G. Evans
    - #79 Edgar W. Evans

GENEALOGY CHARTS

HUSBAND'S NAME: #1 WILLIAM HEMINGRAY

WIFE'S MAIDEN NAME: #2 MARIAH BARLOW\*

MARRIAGE DATE:

PLACE:

<i>Father's Name:</i>		<i>Father's Name:</i>	
<i>Mother's Name:</i>		<i>Mother's Name:</i>	
<i>Date of Birth:</i>	14 Jan 1790	<i>Date of Birth:</i>	
<i>Birthplace:</i>	Heage, Duffield, England**	<i>Birthplace:</i>	
<i>Date of Death:</i>	22 Nov 1832	<i>Date of Death:</i>	1811
<i>Place of Death:</i>	Pittsburgh, PA	<i>Place of Death:</i>	England
<i>Cause of Death:</i>		<i>Cause of Death:</i>	
<i>Age at Death:</i>	42	<i>Age at Death:</i>	
<i>Burial Place:</i>	Allegheny, Pittsburgh, PA	<i>Burial Place:</i>	

\* First wife.

\*\* Derbyshire.

CHILDREN:

	NAME	BIRTH DATE	BIRTHPLACE
1.	#3 George Hemingray	10 Jul 1808	Heage, Duffield, England
2.	#4 William Hemingray, Jr.*	18 Sep 1810	Heage, Duffield, England
3.			
4.			
5.			
6.			
7.			
8.			
9.			
10.			

\* Naturalized 3 Oct 1844. Died 16 Dec 1864, age 54, in Pittsburgh, PA.



HUSBAND'S NAME:#3 GEORGE HEMINGRAY

WIFE'S MAIDEN NAME: #5 HARRIETT

MARRIAGE DATE:

PLACE:

<b>Father's Name:</b>	#1 William Hemingray	<b>Father's Name:</b>	
<b>Mother's Name:</b>	#2 Mariah Barlow	<b>Mother's Name:</b>	
<b>Date of Birth:</b>	10 Jul 1808	<b>Date of Birth:</b>	
<b>Birthplace:</b>	Heage, Duffield, England	<b>Birthplace:</b>	
<b>Date of Death:</b>	29 Aug 1834	<b>Date of Death:</b>	
<b>Place of Death:</b>	Pittsburgh, PA	<b>Place of Death:</b>	
<b>Cause of Death:</b>		<b>Cause of Death:</b>	
<b>Age at Death:</b>	26	<b>Age at Death:</b>	
<b>Burial Place:</b>	Allegheny, Pittsburgh, PA	<b>Burial Place:</b>	

CHILDREN:

	NAME	BIRTH DATE	BIRTHPLACE
1.	#6 Georgeanna Hemingray*		
2.			
3.			
4.			
5.			
6.			
7.			
8.			
9.			
10.			

\* Oliver Blackburn was appointed her guardian by the Allegheny Co. Orphan's Court 8 Nov 1845 following George's death. Harriett and Oliver later married.

HUSBAND'S NAME:#1 WILLIAM HEMINGRAY

WIFE'S MAIDEN NAME: #7 ANN JOHNSON\*

MARRIAGE DATE:

PLACE:

<b>Father's Name:</b>		<b>Father's Name:</b>	
<b>Mother's Name:</b>		<b>Mother's Name:</b>	
<b>Date of Birth:</b>	14 Jan 1790	<b>Date of Birth:</b>	30 Nov 1792
<b>Birthplace:</b>	Heage, Duffield, England**	<b>Birthplace:</b>	
<b>Date of Death:</b>	22 Nov 1832	<b>Date of Death:</b>	29 Aug or 27 Nov 1834
<b>Place of Death:</b>	Pittsburgh, PA	<b>Place of Death:</b>	Pittsburgh, PA
<b>Cause of Death:</b>		<b>Cause of Death:</b>	
<b>Age at Death:</b>	42	<b>Age at Death:</b>	41
<b>Burial Place:</b>	Allegheny, Pittsburgh, PA	<b>Burial Place:</b>	Allegheny, Pittsburgh, PA

\* Second wife.

\*\* Derbyshire.

**CHILDREN:**

	<b>NAME</b>	<b>BIRTH DATE</b>	<b>BIRTHPLACE</b>
1.	#8 Catherine (Kitty) Hemingray (Horner)	5 Jun 1815	Heage, England
2.	#9 Samuel J. Hemingray*	8 May 1817	Heage, England
3.	#10 Robert Hemingray**	22 Jun 1820	Johnstown, PA
4.	#11 Reuben Hemingray***	16 Jun 1823	
5.	#12 Joseph Conway Hemingray***	16 May 1825	Pittsburgh, PA
6.	#13 Mary Jane Hemingray (Evans)***	26 Aug 1829	Pittsburgh, PA
7.			
8.			
9.			
10.			

\* Robert McGill appointed guardian by Allegheny Co. Orphan's Court 29 Oct 1833.

\*\* Samuel Rosenburgh appointed guardian by Allegheny Co. Orphan's Court Jun 1835.

\*\*\* Robert McGill and John White appointed guardians by Allegheny Co. Orphan's Court 1833.



**HUSBAND'S NAME:** #14 CHARLES HORNER, JR.

**WIFE'S MAIDEN NAME:** #8 CATHERINE (KITTY)  
GRIST HEMINGRAY

**MARRIAGE DATE:**

**PLACE:**

<b>Father's Name:</b>	Charles Horner*	<b>Father's Name:</b>	#1 William Hemingray
<b>Mother's Name:</b>	Elizabeth Morrill Horner	<b>Mother's Name:</b>	#7 Ann Johnson
<b>Date of Birth:</b>	24 Feb 1812	<b>Date of Birth:</b>	5 Jun 1815
<b>Birthplace:</b>	Boroughbridge, England	<b>Birthplace:</b>	Heage, Duffield, England
<b>Date of Death:</b>	8 Apr 1853	<b>Date of Death:</b>	17 Feb 1888
<b>Place of Death:</b>	Pittsburgh, PA	<b>Place of Death:</b>	Pittsburgh, PA
<b>Cause of Death:</b>		<b>Cause of Death:</b>	
<b>Age at Death:</b>	41	<b>Age at Death:</b>	72
<b>Burial Place:</b>	Allegheny, Pittsburgh, PA	<b>Burial Place:</b>	Allegheny, Pittsburgh, PA

\* Emigrated to the U. S. in 1832.

**CHILDREN:**

	<b>NAME</b>	<b>BIRTH DATE</b>	<b>BIRTHPLACE</b>
1.	#15 Ann E. Horner*	12 Jan 1838	Pittsburgh, PA
2.	#16 Robert H. Horner*	27 Jul 1840	Pittsburgh, PA
3.	#17 Mary A. Horner*	14 Nov 1842	Pittsburgh, PA
4.	#18 Catherine E. Horner*	7 Jan 1845	Pittsburgh, PA
5.	#19 Charles Morrill Horner	15 Apr 1849	Pittsburgh, PA
6.	#20 Harriet Blanche Horner	26 Aug 1851	Pittsburgh, PA
7.	#21 William Conway Horner	7 Jan 1854	Pittsburgh, PA
8.	#22 Calantha Horner*	2 Jun 1856	Pittsburgh, PA
9.			
10.			

\* Died in infancy.

HUSBAND'S NAME: #9 SAMUEL J. HEMINGRAY\*

WIFE'S MAIDEN NAME: #23 ANN

MARRIAGE DATE:

PLACE:

<b>Father's Name:</b>	#1 William Hemingray	<b>Father's Name:</b>	
<b>Mother's Name:</b>	#7 Ann Johnson	<b>Mother's Name:</b>	
<b>Date of Birth:</b>	1 or 8 May 1817	<b>Date of Birth:</b>	24 Dec 1817
<b>Birthplace:</b>	Heage, England	<b>Birthplace:</b>	Wales
<b>Date of Death:</b>	10 Sep 1866	<b>Date of Death:</b>	16 Nov 1879
<b>Place of Death:</b>	Covington, KY	<b>Place of Death:</b>	
<b>Cause of Death:</b>	Spinal complaint	<b>Cause of Death:</b>	Inflammation of liver
<b>Age at Death:</b>	49**	<b>Age at Death:</b>	61
<b>Burial Place:</b>	Linden Grove, Covington, KY	<b>Burial Place:</b>	Newark, OH

\* Robert McGill appointed guardian by Allegheny Co. Orphan's Court 29 Oct 1833.

\*\* Linden Grove records erroneously list age as 45.

CHILDREN:

	NAME	BIRTH DATE	BIRTHPLACE
1.	#24 Samuel J. Hemingray*	1853	
2.	#25 Henrietta M. Hemingray*	1858	
3.	#26 Camilla L. Hemingray*	1859	
4.			
5.			
6.			
7.			
8.			
9.			
10.			

\* Richard Evans appointed guardian by the Kenton Co. Court following Samuel's death. These three possibly buried in Pittsburgh, PA.



HUSBAND'S NAME #10 ROBERT HEMINGRAY

WIFE'S MAIDEN NAME: #27 MARY ANNE CARROLL\*

MARRIAGE DATE: Jun 1842

PLACE: Pittsburgh, PA

D

D

<b>Father's Name:</b>	#1 William Hemingray	<b>Father's Name:</b>	
<b>Mother's Name:</b>	#7 Ann Johnson	<b>Mother's Name:</b>	
<b>Date of Birth:</b>	22 Jun 1820	<b>Date of Birth:</b>	1821
<b>Birthplace:</b>	Johnstown, PA	<b>Birthplace:</b>	Pittsburgh, PA
<b>Date of Death:</b>	27 Dec 1898	<b>Date of Death:</b>	27 May 1901
<b>Place of Death:</b>	Covington, KY	<b>Place of Death:</b>	Covington, KY
<b>Cause of Death:</b>	Cardiac exhaustion	<b>Cause of Death:</b>	Chronic nephritis
<b>Age at Death:</b>	78	<b>Age at Death:</b>	80
<b>Burial Place:</b>	Highland, Covington, KY	<b>Burial Place:</b>	Highland, Covington, KY

\* Older sister to #83 Susan Carroll, wife of #82 Anthony Gray.

**CHILDREN:**

	<b>NAME</b>	<b>BIRTH DATE</b>	<b>BIRTHPLACE</b>
1.	#28 Camilla Hemingray (Felix)	8 Apr 1843	PA
2.	#29 Anna Johnson Hemingray (Shinkle)	18 Feb 1845	Pittsburgh, PA
3.	#30 Mary Ann Carroll Hemingray (Shinkle)	22 Feb 1847	PA
4.	#31 Catherine (Kate) Hemingray (Swasey)	18 Mar 1849	Cincinnati, OH
5.	#32 Ralph Gray Hemingray	31 Mar 1852	Cincinnati, OH
6.	#33 Robert Carroll Hemingray, Jr.	21 Dec 1854	Covington, KY
7.	#34 Daniel Carroll Hemingray	4 Feb 1857	Covington, KY
8.	#35 "Little Willie" Hemingray*	Oct 1864	Covington, KY
9.			
10.			

\* Buried first at Linden Grove, Covington, KY, then moved to Highland, Covington, KY, 28 Oct 1884. He is not proven to be Robert's son.

HUSBAND'S NAME:#36 WILLIAM H. FELIX\*

WIFE'S MAIDEN NAME: #28 CAMILLA (MELLIE)  
HEMINGRAY

MARRIAGE DATE:

PLACE:

D

<b>Father's Name:</b>		<b>Father's Name:</b>	#10 Robert Hemingray
<b>Mother's Name:</b>		<b>Mother's Name:</b>	#27 Mary Anne Carroll
<b>Date of Birth:</b>	C. 1838	<b>Date of Birth:</b>	8 Apr 1843
<b>Birthplace:</b>		<b>Birthplace:</b>	PA
<b>Date of Death:</b>	Bur. 10 Jan 1912	<b>Date of Death:</b>	28 Nov 1933
<b>Place of Death:</b>		<b>Place of Death:</b>	Fayette Co., KY
<b>Cause of Death:</b>		<b>Cause of Death:</b>	Bulbar paralysis/hyperpie- sis/hypostatic pneumonia**
<b>Age at Death:</b>	74	<b>Age at Death:</b>	90
<b>Burial Place:</b>	Lexington, Lexington, KY	<b>Burial Place:</b>	Lexington, Lexington, KY

\* Became a reverend at age 31. Had children by a previous marriage.

\*\* A specific paralysis leading to strokes/extremely high blood pressure/settling of liquid in lungs.

**CHILDREN:**

	<b>NAME</b>	<b>BIRTH DATE</b>	<b>BIRTHPLACE</b>
1.	#37 William H. Felix, Jr.*	C. 1876	
2.	#38 Annie B. Felix	1880	
3.			
4.			
5.			
6.			
7.			
8.			
9.			
10.			

\* Buried 26 Mar 1918, age 42, Lexington, Lexington, KY.



HUSBAND'S NAME: #39 AMOS CLIFFORD SHINKLE (I)

WIFE'S MAIDEN NAME: #40 SARAH JANE HUGHES

MARRIAGE DATE: 10 Nov 1842

PLACE:

D

D

<b>Father's Name:</b>	Peter Shinkle	<b>Father's Name:</b>	
<b>Mother's Name:</b>	Sarah Day	<b>Mother's Name:</b>	
<b>Date of Birth:</b>	11 Aug 1818	<b>Date of Birth:</b>	C. 1818
<b>Birthplace:</b>	Brown Co., OH	<b>Birthplace:</b>	Brown Co., OH
<b>Date of Death:</b>	13 Nov 1892	<b>Date of Death:</b>	18 Dec 1908
<b>Place of Death:</b>	Covington, KY	<b>Place of Death:</b>	Covington, KY
<b>Cause of Death:</b>	Angina pectoris	<b>Cause of Death:</b>	Senility
<b>Age at Death:</b>	74	<b>Age at Death:</b>	90
<b>Burial Place:</b>	Highland, Covington, KY	<b>Burial Place:</b>	Highland, Covington, KY

CHILDREN:

NAME

BIRTH DATE

BIRTHPLACE

	NAME	BIRTH DATE	BIRTHPLACE
1.	#41 Bradford Shinkle (I)	29 Sep 1845	Higginsport, OH
2.			
3.			
4.			
5.			
6.			
7.			
8.			
9.			
10.			

HUSBAND'S NAME: #41 BRADFORD SHINKLE (1)

WIFE'S MAIDEN NAME: #29 ANNA (ANN) JOHNSON  
HEMINGRAY\*

MARRIAGE DATE: 22 Oct 1868

PLACE: Covington, KY

M D

M D

<b>Father's Name:</b>	#39 Amos C. Shinkle (1)	<b>Father's Name:</b>	#10 Robert Hemingray
<b>Mother's Name:</b>	#40 Sarah Jane Hughes	<b>Mother's Name:</b>	#27 Mary Anne Carroll
<b>Date of Birth:</b>	29 Sep 1845	<b>Date of Birth:</b>	18 Feb 1845
<b>Birthplace:</b>	Higginsport, OH	<b>Birthplace:</b>	Pittsburgh, PA
<b>Date of Death:</b>	7 May 1909	<b>Date of Death:</b>	1 Oct 1884
<b>Place of Death:</b>	Covington, KY	<b>Place of Death:</b>	Covington, KY?
<b>Cause of Death:</b>	Chronic -----? nephritis	<b>Cause of Death:</b>	Paralysis
<b>Age at Death:</b>	63	<b>Age at Death:</b>	39
<b>Burial Place:</b>	Highland, Covington, KY	<b>Burial Place:</b>	Highland, Covington, KY

\* First wife.

CHILDREN:

	NAME	BIRTH DATE	BIRTHPLACE
1.	#42 Camilla Shinkle (Cross)*		
2.	#43 Amos Clifford Shinkle (II)	25 Oct 1877	Covington, KY
3.			
4.			
5.			
6.			
7.			
8.			
9.			
10.			

\* Married Dr. Frank B. Cross.



HUSBAND'S NAME: #43 AMOS CLIFFORD SHINKLE (II) WIFE'S MAIDEN NAME: #44 FRANCES HINKLE

MARRIAGE DATE:

PLACE:

<b>Father's Name:</b>	#41 Bradford Shinkle (I)	<b>Father's Name:</b>	Bradford Hinkle
<b>Mother's Name:</b>	#29 Anna J. Hemingray	<b>Mother's Name:</b>	Kate Davis
<b>Date of Birth:</b>	25 Oct 1877	<b>Date of Birth:</b>	25 Jul 1877
<b>Birthplace:</b>	Covington, KY	<b>Birthplace:</b>	Cincinnati, OH
<b>Date of Death:</b>	4 Apr 1944	<b>Date of Death:</b>	9 Aug 1951
<b>Place of Death:</b>	Cincinnati, OH	<b>Place of Death:</b>	Venice, FL
<b>Cause of Death:</b>	Pulmonary edema	<b>Cause of Death:</b>	Cancer
<b>Age at Death:</b>	66	<b>Age at Death:</b>	74
<b>Burial Place:</b>	Spring Grove, Cincinnati, OH	<b>Burial Place:</b>	Spring Grove, Cincinnati, OH

CHILDREN:

	NAME	BIRTH DATE	BIRTHPLACE
1.	#45 Amos Clifford Shinkle, Jr. (III)*	16 May 1910	Cincinnati, OH
2.	#46 Kate Davis Shinkle**	5 Jul 1914	Westerly, RI
3.			
4.			
5.			
6.			
7.			
8.			
9.			
10.			

\* Died 3 Feb 1950 of cirrhosis of the liver, age 39, in a hospital in Westerly, RI.

\*\* Died 4 Oct 1976 in Westerly, RI.

HUSBAND'S NAME: #41 BRADFORD SHINKLE (I)

WIFE'S MAIDEN NAME: #30 MARY ANN (META)

MARRIAGE DATE:

CARROLL HEMINGRAY\*

PLACE:

D

<b>Father's Name:</b>	#39 Amos C. Shinkle (I)	<b>Father's Name:</b>	#10 Robert Hemingray
<b>Mother's Name:</b>	#40 Sarah Jane Hughes	<b>Mother's Name:</b>	#27 Mary Anne Carroll
<b>Date of Birth:</b>	29 Sep 1845	<b>Date of Birth:</b>	22 Feb 1847
<b>Birthplace:</b>	Higginsport, OH	<b>Birthplace:</b>	PA
<b>Date of Death:</b>	7 May 1909	<b>Date of Death:</b>	16 Jul 1927
<b>Place of Death:</b>	Covington, KY	<b>Place of Death:</b>	Covington, KY
<b>Cause of Death:</b>	Chronic -----? nephritis	<b>Cause of Death:</b>	Neuritis furuscolosis**/chronic myocarditis, hypo. pneum.
<b>Age at Death:</b>	63	<b>Age at Death:</b>	80
<b>Burial Place:</b>	Highland, Covington, KY	<b>Burial Place:</b>	Highland, Covington, KY

\* Second wife.

\*\* Inflammation of nerve.

CHILDREN:

	NAME	BIRTH DATE	BIRTHPLACE
1.	#47 Bradford Shinkle, Jr. (II)*		
2.			
3.			
4.			
5.			
6.			
7.			
8.			
9.			
10.			

\* Living in St. Louis in 1927.



HUSBAND'S NAME: #48 MOSES SWASEY

WIFE'S MAIDEN NAME: #49 MARIA R. PACK

MARRIAGE DATE:

PLACE:

<i>Father's Name:</i>		<i>Father's Name:</i>	
<i>Mother's Name:</i>		<i>Mother's Name:</i>	
<i>Date of Birth:</i>		<i>Date of Birth:</i>	1813
<i>Birthplace:</i>		<i>Birthplace:</i>	PA
<i>Date of Death:</i>		<i>Date of Death:</i>	25 Nov 1883
<i>Place of Death:</i>		<i>Place of Death:</i>	Cincinnati, OH*
<i>Cause of Death:</i>		<i>Cause of Death:</i>	Paralysis of throat/old age
<i>Age at Death:</i>		<i>Age at Death:</i>	C. 70
<i>Burial Place:</i>		<i>Burial Place:</i>	Spring Grove, Cincinnati, OH

\* 10 Eastbourne Terrace

CHILDREN:

	<i>NAME</i>	<i>BIRTH DATE</i>	<i>BIRTHPLACE</i>
1.	#50 William H. Swasey	1845	Cincinnati, OH
2.	#51 Ella Maria Swasey	20 Nov 1846	Cincinnati, OH
3.	#52 Edward D. Swasey	1848	KY
4.			
5.			
6.			
7.			
8.			
9.			
10.			

HUSBAND'S NAME: #52 EDWARD D. SWASEY

WIFE'S MAIDEN NAME: #31 CATHERINE (KATE)  
HEMINGRAY

MARRIAGE DATE: 26 Jan 1871

PLACE: Covington, KY

M

M

<b>Father's Name:</b>	#48 Moses Swasey *	<b>Father's Name:</b>	#10 Robert Hemingray
<b>Mother's Name:</b>	#49 Maria R. Pack	<b>Mother's Name:</b>	#27 Mary Anne Carroll
<b>Date of Birth:</b>	1848	<b>Date of Birth:</b>	18 Mar 1849
<b>Birthplace:</b>	Cincinnati, OH	<b>Birthplace:</b>	Cincinnati, OH
<b>Date of Death:</b>	29 Jan 1909	<b>Date of Death:</b>	3 Sep 1881
<b>Place of Death:</b>	Cincinnati, OH	<b>Place of Death:</b>	
<b>Cause of Death:</b>	Exhaustion and enteritis	<b>Cause of Death:</b>	Typhoid fever
<b>Age at Death:</b>	61	<b>Age at Death:</b>	32
<b>Burial Place:</b>	Spring Grove, Cincinnati, OH	<b>Burial Place:</b>	Highland, Covington, KY

\* From Vermont.

CHILDREN:

	NAME	BIRTH DATE	BIRTHPLACE
1.	#53 Mary E. Swasey (Long)*	1871	Covington, KY
2.			
3.			
4.			
5.			
6.			
7.			
8.			
9.			
10.			

\* Died 9 Dec 1917, age 46, in Covington, KY, of hemorrhage. She is buried in Highland, Covington, KY



HUSBAND'S NAME: #32 RALPH GRAY HEMINGRAY

WIFE'S MAIDEN NAME: #54 JANE (JENNIE) P. MATTHEWS\*

MARRIAGE DATE: 2 Nov 1875

PLACE: Covington, KY

M D

M

<b>Father's Name:</b>	#10 Robert Hemingray	<b>Father's Name:</b>	**
<b>Mother's Name:</b>	#27 Mary Anne Carroll	<b>Mother's Name:</b>	**
<b>Date of Birth:</b>	31 March 1852	<b>Date of Birth:</b>	C. 1856
<b>Birthplace:</b>	Cincinnati, OH	<b>Birthplace:</b>	Maysville, KY
<b>Date of Death:</b>	11 May 1920	<b>Date of Death:</b>	2 Sep 1900
<b>Place of Death:</b>	Covington, KY	<b>Place of Death:</b>	Muncie, IN
<b>Cause of Death:</b>	Uremia/pleurisy***	<b>Cause of Death:</b>	Tuberculosis
<b>Age at Death:</b>	68	<b>Age at Death:</b>	44
<b>Burial Place:</b>	Highland, Covington, KY	<b>Burial Place:</b>	Highland, Covington, KY

\* First wife.

\*\* From KY.

\*\*\* Toxicity in blood leading to kidney failure/inflammation of lining of lung.

CHILDREN:

	NAME	BIRTH DATE	BIRTHPLACE
1.	#55 Llewellyn Matthews Hemingray*	1876	
2.	#56 Mintie Carroll Hemingray (McAbee)	6 Mar 1880	Covington, KY
3.			
4.			
5.			
6.			
7.			
8.			
9.			
10.			

\* Died 5 Oct 1942, age 66, and is buried in Highland, Covington, KY. She never married.

HUSBAND'S NAME: #57 PHILIP WARRINGTON McABEE

WIFE'S MAIDEN NAME: #56 MINTIE (MINNIE)  
CARROLL HEMINGRAY

MARRIAGE DATE: 24 Apr 1907

PLACE:

D

D

<i>Father's Name:</i>	Newton S. McAbee	<i>Father's Name:</i>	#32 Ralph Gray Hemingray
<i>Mother's Name:</i>	Mary J. Green	<i>Mother's Name:</i>	#54 Jane P. Matthews
<i>Date of Birth:</i>	22 Sep 1880*	<i>Date of Birth:</i>	6 Mar 1880**
<i>Birthplace:</i>	Cleveland, OH	<i>Birthplace:</i>	Covington, KY
<i>Date of Death:</i>	7 Nov 1948	<i>Date of Death:</i>	26 Feb 1947
<i>Place of Death:</i>	Knoxville, TN	<i>Place of Death:</i>	Cocoa, FL
<i>Cause of Death:</i>	Heart attack	<i>Cause of Death:</i>	Heart attack
<i>Age at Death:</i>	68	<i>Age at Death:</i>	66
<i>Burial Place:</i>	Beech Grove, Muncie, IN	<i>Burial Place:</i>	Beech Grove, Muncie, IN

\* Marriage application says 1877.

\*\* Marriage application says 1878.

CHILDREN:

	NAME	BIRTH DATE	BIRTHPLACE
1.	#58 Ralph Hemingray McAbee*	1908	Cleveland, OH
2.			
3.			
4.			
5.			
6.			
7.			
8.			
9.			
10.			

\* Died 26 Jul 1910 in Cleveland, OH, of an undetermined infection. Removed to Beech Grove, Muncie, IN, 21 Jul 1947.



HUSBAND'S NAME: #32 RALPH GRAY HEMINGRAY

WIFE'S MAIDEN NAME: #59 EVA HOLLINGER\*

MARRIAGE DATE: After Sep 1900

PLACE:

D

<b>Father's Name:</b>	#10 Robert Hemingray	<b>Father's Name:</b>	Martin Hollinger
<b>Mother's Name:</b>	#27 Mary Anne Carroll	<b>Mother's Name:</b>	Eva Mary Fischer
<b>Date of Birth:</b>	31 Mar 1852	<b>Date of Birth:</b>	1883
<b>Birthplace:</b>	Cincinnati, OH	<b>Birthplace:</b>	Terre Haute, IN
<b>Date of Death:</b>	11 May 1920	<b>Date of Death:</b>	21 Feb 1947
<b>Place of Death:</b>	Covington, KY	<b>Place of Death:</b>	Muncie, IN
<b>Cause of Death:</b>	Uremia/pleurisy	<b>Cause of Death:</b>	Hypertension
<b>Age at Death:</b>	68	<b>Age at Death:</b>	64
<b>Burial Place:</b>	Highland, Covington, KY	<b>Burial Place:</b>	Woodlawn, Terre Haute, IN

\* Second wife.

CHILDREN: None

	NAME	BIRTH DATE	BIRTHPLACE
1.			
2.			
3.			
4.			
5.			
6.			
7.			
8.			
9.			
10.			

**HUSBAND'S NAME:** #33 ROBERT CARROLL HEMINGRAY,  
JR.  
**MARRIAGE DATE:**

**WIFE'S MAIDEN NAME:** #60 MINNIE (NANNIE OR  
ANNA) TAYLOR TIMBERLAKE  
**PLACE:**

B		D	
<b>Father's Name:</b>	#10 Robert Hemingray	<b>Father's Name:</b>	Henry C. Timberlake
<b>Mother's Name:</b>	#27 Mary Anne Carroll*	<b>Mother's Name:</b>	Susan Tibatts
<b>Date of Birth:</b>	21 Dec 1854	<b>Date of Birth:</b>	26 Feb 1859
<b>Birthplace:</b>	Covington, KY	<b>Birthplace:</b>	Newport, KY
<b>Date of Death:</b>	26 Jul 1901	<b>Date of Death:</b>	12 Jun 1915
<b>Place of Death:</b>	Cincinnati, OH	<b>Place of Death:</b>	Los Angeles, CA
<b>Cause of Death:</b>	Cerebral hemorrhage	<b>Cause of Death:</b>	Carcinoma of left breast
<b>Age at Death:</b>	46	<b>Age at Death:</b>	56
<b>Burial Place:</b>	Highland, Covington, KY	<b>Burial Place:</b>	Highland, Covington, KY

\* Birth record lists mother as Clara Ringold (an obvious error).

**CHILDREN:**

	<b>NAME</b>	<b>BIRTH DATE</b>	<b>BIRTHPLACE</b>
1.	#61 Robert (Robin) C. Hemingray, Jr.	1878	
2.	#62 Conway (Con) T. Hemingray	1880	
3.	#63 Susan Ashley Hemingray (Starr)*		
4.			
5.			
6.			
7.			
8.			
9.			
10.			

\* Mrs. Shunim? Starr.



HUSBAND'S NAME: #34 DANIEL CARROLL HEMINGRAY

WIFE'S MAIDEN NAME: #64 CLARA KECK

MARRIAGE DATE:

PLACE:

D

<b>Father's Name:</b>	#10 Robert Hemingray	<b>Father's Name:</b>	Cyrus "Sy" Keck
<b>Mother's Name:</b>	#27 Mary Anne Carroll	<b>Mother's Name:</b>	
<b>Date of Birth:</b>	4 Feb 1857	<b>Date of Birth:</b>	1856
<b>Birthplace:</b>	Covington, KY	<b>Birthplace:</b>	Cincinnati, OH
<b>Date of Death:</b>	14 Dec 1911	<b>Date of Death:</b>	30 Dec 1943
<b>Place of Death:</b>	Cincinnati, OH	<b>Place of Death:</b>	Cincinnati, OH
<b>Cause of Death:</b>	Apoplexy (stroke)	<b>Cause of Death:</b>	Pneumonia/congestive heart failure
<b>Age at Death:</b>	54	<b>Age at Death:</b>	87
<b>Burial Place:</b>	Highland, Covington, KY	<b>Burial Place:</b>	Highland, Covington, KY

CHILDREN: None

	NAME	BIRTH DATE	BIRTHPLACE
1.			
2.			
3.			
4.			
5.			
6.			
7.			
8.			
9.			
10.			

HUSBAND'S NAME: #11 REUBEN HEMINGRAY

WIFE'S MAIDEN NAME: #65 CAROLINE

MARRIAGE DATE:

PLACE:

<i>Father's Name:</i>	#1 William Hemingray	<i>Father's Name:</i>	
<i>Mother's Name:</i>	#7 Ann Johnson	<i>Mother's Name:</i>	
<i>Date of Birth:</i>	16 Jun 1823	<i>Date of Birth:</i>	C. 1824
<i>Birthplace:</i>		<i>Birthplace:</i>	
<i>Date of Death:</i>		<i>Date of Death:</i>	1866
<i>Place of Death:</i>		<i>Place of Death:</i>	
<i>Cause of Death:</i>		<i>Cause of Death:</i>	
<i>Age at Death:</i>		<i>Age at Death:</i>	
<i>Burial Place:</i>		<i>Burial Place:</i>	

CHILDREN:

	NAME	BIRTH DATE	BIRTHPLACE
1.	#66 Reuben P. Hemingray		
2.	#67 Robert B. Hemingray		
3.	#68 William B. Hemingray		
4.			
5.			
6.			
7.			
8.			
9.			
10.			



HUSBAND'S NAME: #12 JOSEPH CONWAY HEMINGRAY

WIFE'S MAIDEN NAME: #69 MARIA G. HAWN

MARRIAGE DATE:

PLACE:

<b>Father's Name:</b>	#1 William Hemingray	<b>Father's Name:</b>	
<b>Mother's Name:</b>	#7 Ann Johnson	<b>Mother's Name:</b>	
<b>Date of Birth:</b>	16 May 1825	<b>Date of Birth:</b>	Sep 1839
<b>Birthplace:</b>	Pittsburgh, PA	<b>Birthplace:</b>	IL
<b>Date of Death:</b>	21 May 1891	<b>Date of Death:</b>	14 Jun 1927
<b>Place of Death:</b>	Louisville, KY	<b>Place of Death:</b>	Louisville, KY
<b>Cause of Death:</b>	Heart attack	<b>Cause of Death:</b>	
<b>Age at Death:</b>	66	<b>Age at Death:</b>	87
<b>Burial Place:</b>	Cave Hill, Louisville, KY	<b>Burial Place:</b>	Cave Hill, Louisville, KY

CHILDREN:

	NAME	BIRTH DATE	BIRTHPLACE
1.	#70 Reuben P. Hemingray		
2.	#71 Lillian K. Hemingray (Chambers)*	Dec 1866	KS
3.			
4.			
5.			
6.			
7.			
8.			
9.			
10.			

\* Or Lilliene. Died in 1938.

HUSBAND'S NAME: #70 REUBEN P. HEMINGRAY\*

WIFE'S MAIDEN NAME: #72 LIDA BLACKER\*\*

MARRIAGE DATE:

PLACE:

<i>Father's Name:</i>	#12 Joseph C. Hemingray	<i>Father's Name:</i>	
<i>Mother's Name:</i>	#69 Maria G. Hawn	<i>Mother's Name:</i>	
<i>Date of Birth:</i>		<i>Date of Birth:</i>	
<i>Birthplace:</i>		<i>Birthplace:</i>	
<i>Date of Death:</i>		<i>Date of Death:</i>	
<i>Place of Death:</i>		<i>Place of Death:</i>	
<i>Cause of Death:</i>		<i>Cause of Death:</i>	
<i>Age at Death:</i>		<i>Age at Death:</i>	
<i>Burial Place:</i>		<i>Burial Place:</i>	

\* Declared dead by court 13 Oct 1902.

\*\* Second marriage to Kerrick.

CHILDREN:

	NAME	BIRTH DATE	BIRTHPLACE
1.			
2.			
3.			
4.			
5.			
6.			
7.			
8.			
9.			
10.			



HUSBAND'S NAME: #73 CHARLES WILLIAM CHAMBERS

WIFE'S MAIDEN NAME: #71 LILLIAN K. HEMINGRAY

MARRIAGE DATE:

PLACE:

<b>Father's Name:</b>		<b>Father's Name:</b>	#12 Joseph C. Hemingray
<b>Mother's Name:</b>		<b>Mother's Name:</b>	#69 Maria G. Hawn
<b>Date of Birth:</b>	Jun 1860	<b>Date of Birth:</b>	Dec 1866
<b>Birthplace:</b>	IN	<b>Birthplace:</b>	KS
<b>Date of Death:</b>	1 Jul 1910	<b>Date of Death:</b>	1 Nov 1938
<b>Place of Death:</b>	Louisville, KY	<b>Place of Death:</b>	Louisville, KY
<b>Cause of Death:</b>		<b>Cause of Death:</b>	
<b>Age at Death:</b>		<b>Age at Death:</b>	
<b>Burial Place:</b>		<b>Burial Place:</b>	

CHILDREN:

	NAME	BIRTH DATE	BIRTHPLACE
1.	#74 Reubin Hemingray Chambers	Mar 1892	Louisville, KY
2.	#75 Gertrude Lamar Chambers (Donnelly)*	Jun 1898	Louisville, KY
3.	#76 Charles William Chambers, Jr.		
4.			
5.			
6.			
7.			
8.			
9.			
10.			

\* Married James B. Donnelly.

HUSBAND'S NAME: #77 RICHARD G. EVANS

WIFE'S MAIDEN NAME: #13 MARY JANE HEMINGRAY

MARRIAGE DATE: 14 Nov 1855

PLACE: Covington, KY

M D

M D

<b>Father's Name:</b>		<b>Father's Name:</b>	#1 William Hemingray
<b>Mother's Name:</b>		<b>Mother's Name:</b>	#7 Ann Johnson
<b>Date of Birth:</b>	17 Feb 1828	<b>Date of Birth:</b>	26 Aug 1829
<b>Birthplace:</b>	Brownsville, PA	<b>Birthplace:</b>	Pittsburgh, PA
<b>Date of Death:</b>	17 Jan 1897	<b>Date of Death:</b>	5 Jul 1902
<b>Place of Death:</b>	Covington, KY	<b>Place of Death:</b>	Covington, KY
<b>Cause of Death:</b>	Apoplexia	<b>Cause of Death:</b>	
<b>Age at Death:</b>	68	<b>Age at Death:</b>	72
<b>Burial Place:</b>	Highland, Covington, KY	<b>Burial Place:</b>	Highland, Covington, KY

CHILDREN:

	NAME	BIRTH DATE	BIRTHPLACE
1.	#78 Richard G. Evans	Sep 1859	Covington, KY
2.	#79 Edgar W. Evans*	1873	Covington, KY
3.			
4.			
5.			
6.			
7.			
8.			
9.			
10.			

\* Three additional children died in infancy. Names, sex, dates of birth and death unknown.



HUSBAND'S NAME: #80 RALPH GRAY

WIFE'S MAIDEN NAME: #81 ANN FRIAR

MARRIAGE DATE:

PLACE:

D

<i>Father's Name:</i>		<i>Father's Name:</i>	*
<i>Mother's Name:</i>		<i>Mother's Name:</i>	Mary*
<i>Date of Birth:</i>	1815	<i>Date of Birth:</i>	16 Oct 1812
<i>Birthplace:</i>	England	<i>Birthplace:</i>	Ireland
<i>Date of Death:</i>	20 Nov 1863	<i>Date of Death:</i>	27 Oct 1902
<i>Place of Death:</i>	Covington, KY**	<i>Place of Death:</i>	Covington, KY
<i>Cause of Death:</i>	Abcess of liver	<i>Cause of Death:</i>	Cerebral hemorrhage
<i>Age at Death:</i>	48	<i>Age at Death:</i>	90
<i>Burial Place:</i>	Spring Grove, Cincinnati, OH	<i>Burial Place:</i>	Spring Grove, Cincinnati, OH

\* From Ireland.

\*\* Buried first in Linden Grove, moved to Spring Grove Dec 1899.

CHILDREN:

	NAME	BIRTH DATE	BIRTHPLACE
1.			
2.			
3.			
4.			
5.			
6.			
7.			
8.			
9.			
10.			

HUSBAND'S NAME: #82 ANTHONY GRAY

WIFE'S MAIDEN NAME: #83 SUSAN CARROLL\*

MARRIAGE DATE:

PLACE:

<i>Father's Name:</i>		<i>Father's Name:</i>	
<i>Mother's Name:</i>		<i>Mother's Name:</i>	
<i>Date of Birth:</i>	1822	<i>Date of Birth:</i>	C. 1828
<i>Birthplace:</i>	PA	<i>Birthplace:</i>	Pittsburgh, PA
<i>Date of Death:</i>	27 Apr 1865	<i>Date of Death:</i>	19 Aug 1866
<i>Place of Death:</i>		<i>Place of Death:</i>	
<i>Cause of Death:</i>		<i>Cause of Death:</i>	
<i>Age at Death:</i>	43	<i>Age at Death:</i>	39
<i>Burial Place:</i>	Linden Grove, Covington, KY	<i>Burial Place:</i>	Linden Grove, Covington, KY

\* Younger sister to #27, Mary Carroll, wife of #8, Robert Hemingray.

CHILDREN:

	NAME	BIRTH DATE	BIRTHPLACE
1.	#84 Elizabeth Gray	C. 1850	OH
2.	#85 John C. Gray	C. 1855	KY
3.	#86 Anna Gray	C. 1857	KY
4.	#87 Catherine (Kate) Gray	C. 1860	KY
5.	#88 Ralph Gray?		
6.			
7.			
8.			
9.			
10.			



HUSBAND'S NAME: #89 JAMES L. FOLEY

WIFE'S MAIDEN NAME: #90 JULIET BARNES

MARRIAGE DATE:

PLACE:

<i>Father's Name:</i>		<i>Father's Name:</i>	
<i>Mother's Name:</i>		<i>Mother's Name:</i>	
<i>Date of Birth:</i>	10 Aug 1837	<i>Date of Birth:</i>	28 May 1841
<i>Birthplace:</i>		<i>Birthplace:</i>	Mt. Sterling, KY
<i>Date of Death:</i>	5 Aug 1910	<i>Date of Death:</i>	28 Jun 1906
<i>Place of Death:</i>		<i>Place of Death:</i>	Cincinnati, OH
<i>Cause of Death:</i>		<i>Cause of Death:</i>	
<i>Age at Death:</i>	72	<i>Age at Death:</i>	65
<i>Burial Place:</i>	Highland, Covington, KY	<i>Burial Place:</i>	Highland, Covington, KY

CHILDREN:

	<i>NAME</i>	<i>BIRTH DATE</i>	<i>BIRTHPLACE</i>
1.			
2.			
3.			
4.			
5.			
6.			
7.			
8.			
9.			
10.			

GENEALOGY CHART FOR THE GRAYS

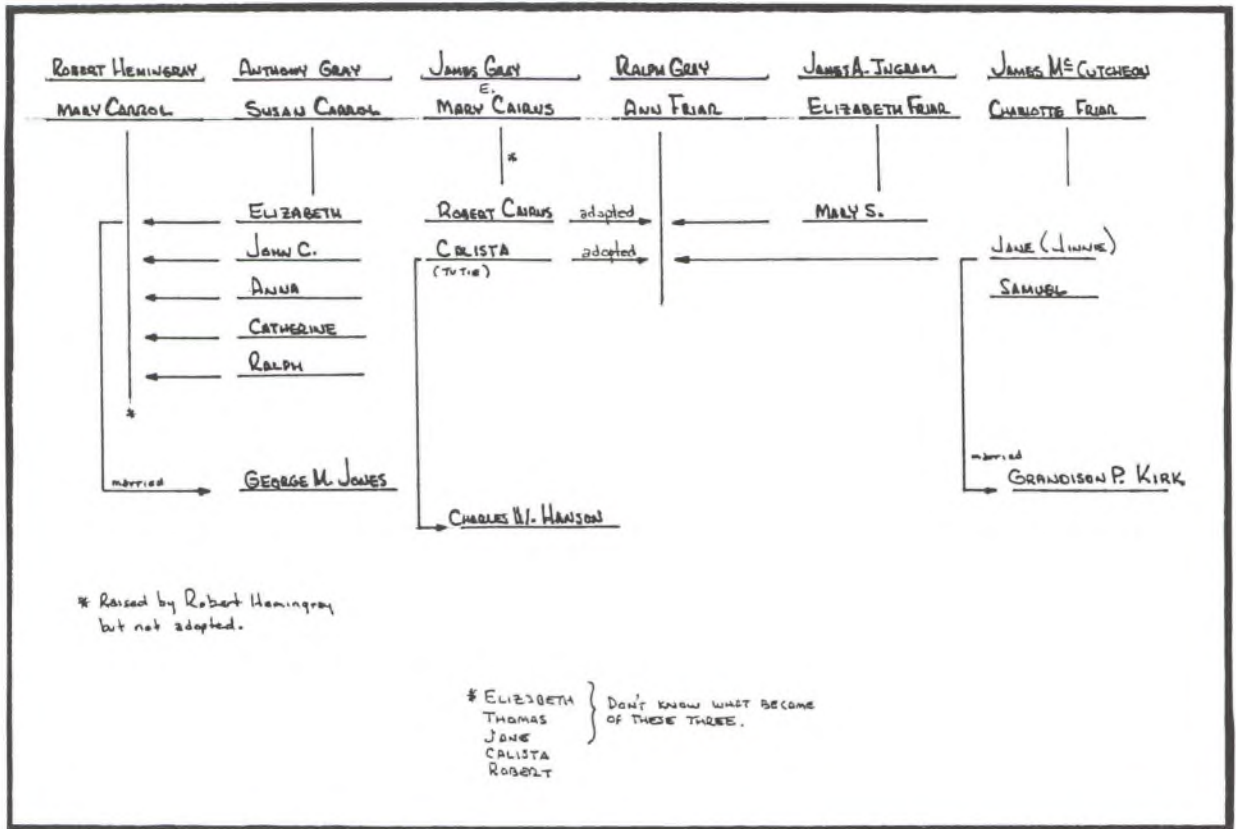

Chart drawn by Glenn Drummond  
(Courtesy of Glenn Drummond)

TRADE MARK  
STANDARD HEMINGRAY INSULATORS  
REGISTERED.



# THE MAIL ROOM



CD 162







## **A FEW NOTES ABOUT THE MAIL ROOM**

"The Mail Room" was designed to hold all of the letters that would have taken too much room in the main text and would have distracted readers and gotten them off of the subject. However, I felt that these letters were important to the story and I didn't want to leave them out.

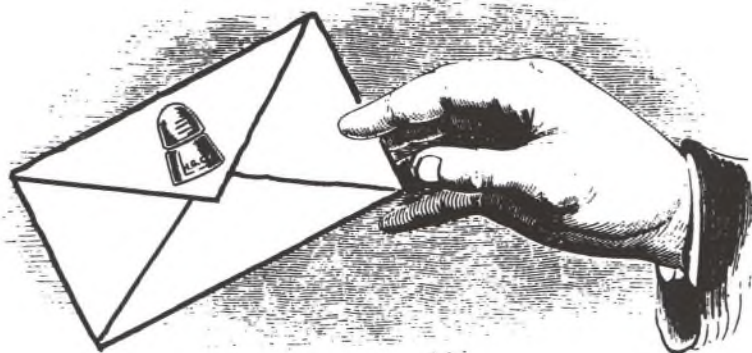

[27 November 1996]

Mrs. Gordon,

I was very interested in your recent letter of inquiry about the old Hemingray company. First let me say that I believe that you have a pretty good grasp of the process of glassmaking. So I will concern my "narrative" to my own thoughts and experiences with that era. And, may I say, too, that I am past eighty-two years of age, and that I am using a Brother word processor. This thing is so much "smarter" than I am that I feel I shall not live to master it. So please forgive the errors and just consider the thought.

I was first employed by H. G. Co. in 1931 at the tender age of sixteen. It was a deep depression time and work was hard to get, so that I am the only one to have 1931 seniority. As of today there are only three of the old "boys" still extant. I was paid at the rate of twenty-five cents an hour, and glad to get it! At first I had no steady job but caught "extras" by appearing at the gate at the time the shift changed to get to work if someone did not show up. I remember one week I worked but one hour, and drew a check for twenty-five cents, less ten cents for Community Fund (now United Way). Perhaps I should have saved that check but fifteen cents was good money in those days. In Muncie that year Indian Green gasoline was nine cents a gallon. Bread was also nine cents as were Camel cigarettes. But I digress.

In 1888 Ralph and Robert Hemingray brought their flood ravished plant from Covington, KY, to our town, because of the promise of free gas which was plentiful and thought to be everlasting. They built their plant on the east side of Macedonia Ave. and later became the world's largest producer of glass insulators. Also in that year the five Ball brothers of Buffalo, NY, built their plant on the west side of the street and later became the world's largest producer of packer ware (canning jars).

I never saw either Ralph or Bob H. as they were both gone by the time I arrived. But I saw Carrol [Mintie Carroll] who was the daughter of Ralph. She was married to Col. Phil McAbee who was quite a character...

It is said of Ralph that he was quite a character himself. He smoked cigarettes which he rolled himself, using bag tobacco and cigarette papers. I understand that he could do this with one hand. At one time the city administration passed a law that forbade smoking on the streets of the town. So, as the story goes, Ralph went downtown and, after joining two policemen, proceeded to roll a cigarette. He was quickly informed that he had broken the law and would be arrested. He replied that



if he was arrested he would move his factory out of Muncie.  
You can be sure that was the end of that foolishness!

...The plant was shut down on July 17, 1972. I had been in supervision for many years, so it became my duty to get the warehouses cleared out. Employees had to be 58 years of age in order to take early retirement. I was 58 on September 17 and I had the warehouses emptied as of October 1, so I took my pension and retired. The rest of my working life I spent working for two local banks, again retiring last March 1.

*TEMPUS FIDGETS. MORE LATER.*

*That is all for now.*

*Ern Parkison*

(Many thanks to Ern Parkison for this  
detailed and informative letter)

# OWENS-ILLINOIS

GENERAL OFFICES ① TOLEDO, OHIO 43601

CONSUMER AND TECHNICAL PRODUCTS DIVISION

June 19, 1972

TO: ALL EMPLOYEES OF THE MUNCIE PLANT

I deeply regret to inform you that the Company must discontinue operations at the Muncie plant. This decision is made with great reluctance and only after years of efforts to keep the plant operating. However, we have no alternative because the plant's age and its layout make it impractical to adapt it to the production of the type of color television parts that now are required by the industry.

In order to meet the demands of color television set manufacturers, Owens-Illinois would, in effect, have to completely rebuild the Muncie plant. Since our larger plants at Columbus, Ohio and Pittston, Pa., are now supplying all of the needs of the available market and are expected to continue doing so, such a new plant is not needed in the foreseeable future.

Before reaching the decision to close the plant, we explored with other operating divisions of Owens-Illinois the possibility of their taking it over for their operations. Unfortunately, none of them have any need for the plant now.

The Batch and Furnace and Forming Departments will cease operations at 7:00 a.m. on Saturday, July 15. Other departments will continue operating until their work is completed. Your supervisor will inform you of the shutdown date of your department as soon as possible.

Owens-Illinois deeply regrets any problems the plant's shutdown may cause you. I assure you that the Company will do everything it can to help. Some of you with long service with the Company are eligible for early retirement and that option will be explained to you. We will be glad to contact other Company plants on behalf of those of you who may be interested in jobs outside Muncie. We also will do everything we can to help you find work in the Muncie area.

Your supervisor will discuss your individual situation with you in the near future. You also will be informed of any benefits which may be due you under Company policy or our labor agreement with the American Flint Glass Workers Union.

Sincerely,

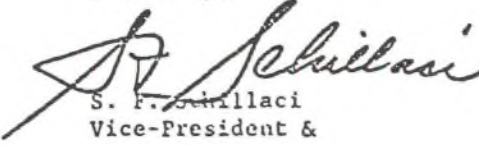
  
S. F. Schillaci  
Vice-President &  
General Manager

Letter from O-I to employees about closing of plant.

19 Jun 1972

(Courtesy of Glenn Drummond)





Al G. Smith  
Director, Corporate  
Information Services

April 1, 1976

Dear Mr. Drummond:

Here for your information is all the historical information I have in my files on the Hemingray Glass Company.

Recalling our conversation at the insulator show here Saturday, our information on the early days of Hemingray at Cincinnati and Covington is inaccurate as well as very sketchy. I will appreciate your sharing with me your more accurate information on Hemingray's history at Cincinnati and Covington as well as anything you may have about the Muncie days.

I am ordering a copy of N. R. Woodward's "The Glass Insulator in America" from Old Bottle Magazine, but will update my copy on the basis of the information you supply me.

For your information, the Muncie plant has been closed for several years and the company now has it up for sale.

It was good talking with you and your wife at the show Saturday.

Sincerely,

Al G. Smith

(This letter and the history on the following page is courtesy of Glenn Drummond)

Cincinnati, December 7th, 1888.  
The Hemingray Glass Co.,  
Covington, Ky.

Gentlemen:-

I have carefully examined the patents on insulators No. 288,360, granted November 13th, 1883, to Samuel Oakman and No. 14674, granted same party, February 12th, 1884, for design for an insulator.

The first claim of No. 288,360, is as follows:

"A glass insulator having formed within its interior, a screw thread D, recess [G'], shield E, and recess H, all substantially as subscribed and for the purpose set forth."

Upon comparing this claim with the insulator submitted to me and proposed to be manufactured by you, I find this insulator has no recess [G'], which is a prominent and essential element of the claim, and it does not infringe this claim.

The second claim of this patent, is:

"A glass insulator having formed within its interior a screw thread D, shield E, and recess H, in combination with the screw peg P, all substantially as subscribed, and for the purpose set forth."

The only elements of this claim, that are at all new, are the shield E, (or the petticoat), and the recess H. The screw peg is made an element of this claim, and in manufacturing the insulators, you would not infringe the claim, but if the claim were valid, the parties applying them, would use the screw peg and therefore come within the purview of the claim. The novel elements of the claim, to wit: The shield E, and recess H, are clearly shown in the old insulator manufactured by you, I think you stated as early as 1869, the only difference being a difference of degree, which is never patentable. I am satisfied that the extent of the manufacture by you and the character of it, was such as to take it out from under the law relating to abandoned experiments, and consequently make it a complete anticipation of this claim of the patent, I can therefore unhesitatingly say, that this claim is invalid upon the evidence now in your possession. I believe other evidence can be produced also, to defeat the claim.



As to the design patent, the claim is as follows:  
"The design for an insulator herein shown and described, the body having the shape or configurations of a paraboloid transversed by an equatorial groove."

The last form of insulator submitted to me, is not a paraboloid, the lower part or skirt flares outwardly, making a reverse curve. It would not therefore infringe the claim of the design patent, but in addition to that, it is within my own knowledge and doubtless within your [sic], that insulators in the shape of a paraboloid, were made and used long prior to 1884, and while they may not be shown in the records of the Patent Office, they are certainly very old in public use, and the patent is unquestionably invalid.

Very respectfully,

(Dictated)

(Arthur Stem)

Letter from Hemingray lawyer Arthur Stem.  
(See pages 403 through 406 for Oakman patents  
referenced in above letter)

7 Dec 1888

(Courtesy of Glenn Drummond)

(Hemingray lawyer Arthur Stem had an office at 216 Main in Cincinnati. This letter was found in a Cincinnati antique shop and is shared with us by Glenn Drummond.)

TRADE MARK  
STANDARD HEMINGRAY INSULATORS  
REGISTERED.





# THE NEWS ROOM



CD 151





## A FEW NOTES ABOUT THE NEWS ROOM

"The News Room" contains newspaper articles that would have taken too much room in the main text. Ninety-nine percent of these articles were researched and typed by Glenn Drummond, and sent to me by Bill Meier, who was borrowing them from Glenn at the time. I am very grateful for these articles because they give greater insight into the history of the Hemingray Glass Company.

I have tried not to duplicate any articles. In other words, if a certain article appears in the text, it won't appear in this section. (In the main text, a few times I had the original article, but because it was illegible, I had to use the typed version instead. In a few cases I used both.)

To fill in blank spaces, I have scattered drawings of Hemingray insulators throughout this section, taken from an Ohio Brass Company catalog dated 1899. These pages were sent to me by Elton Gish, for which I thank him so much. These insulators are not always shown at their original size. I have added their price at the time because I found that interesting. I have also given them Mr. Woodward's CD numbers for easier identification.

I thank Glenn Drummond for sharing his hours of research and typing on these articles. And thanks too, to Bill, for sending them to me. I hope you will read every article because they are full of good information.



MUNCIE DAILY TIMES

12 July 1887

Page 1, col. 5.

\*\*\*\*\*

GLASS WORKS

-----

A Proposition Submitted For  
Their Location in Muncie

-----

This morning a proposition was submitted by a company now owning and operating a large Glass Factory to locate in Muncie. For prudential reasons the name and present location of the firm is not given. But suffice it to say that the Manufacturers' Committee of the Board of Trade has received such a proposition as meets with general favor with the committee.

Recognizing the fact that the manufacturing interests will eventually concentrate in the gas belt, these gentlemen are seeking a location. They propose to commence operation with not less than 125 hands, and will guarantee to operate 200 within two years. What they ask, and other details, will be given in a short time.

\*\*\*\*\*

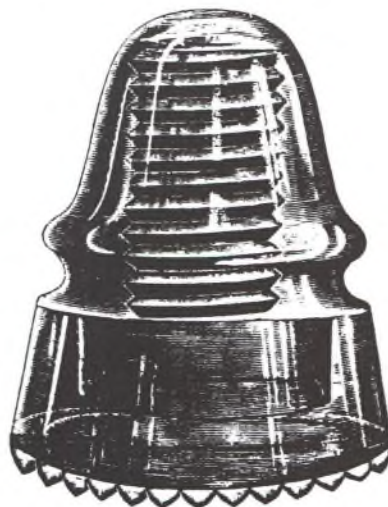

CD 160  
\$28.80 per 1000



MUNCIE DAILY TIMES

14 July 1887

Page 1, col. 5

\* \* \* \* \*

THE MAMMOTH GLASS FACTORY

-----

Muncie Can Have it if the  
Citizens Do Their Part.

-----

At the Board of Trade meeting last night the proposition submitted for the locating of a glass factory was accepted, the same being conditioned on the raising of \$7,500. A committee for securing this money was appointed as follows: Frank Bratton, Frank Leon, A. L. Kerwood, W. L. Lacey, Ed M. White, and F. L. Wachtell. The committee was instructed to call to its aid any citizens that it might wish to assist it.

The general sentiment is that this is the best proposition yet made, and all who have expressed themselves say that the offer must not be allowed to pass.

There should be no hesitating on the part of anyone in aiding this enterprise. Starting with 125 hands and adding 175 within two years, this establishment alone will add from 1,000 to 1,500 to our population in a short time.

With this factory secured in addition to the one on which work is already begun, the lively and money making times of the boom will return to remain.

There is a tide in the affairs of men which taken at the flood leads on to fortune.

\* \* \* \* \*

THE MUNCIE DAILY NEWS

5 January 1888

Page 4, col. 3

\*\*\*\*\*

MUNCIE'S PROSPERITY.

ANOTHER IMMENSE GLASS  
FACTORY COMING.

-----  
AN AGREEMENT WITH THE  
HEMINGGRAYS SIGNED.

AND THEY LOCATE THEIR  
COVINGTON FACTORY  
IN MUNCIE.

-----  
You can't keep an honest man down, neither can an energetic city be kept in the background. Muncie is reaching out with colossal strides. A few years ago we were a village, then a town and now we are a city. The elixir of this wonderful growth is gas. Gas permeates the whole growth yet this gas has not caused a mushroom growth. The gas alone would not have brought about our prosperous growing condition. Heretofore Muncie has been behind what she should be and even now it is only assuming the rank that location and enterprise would rightly give it.

For the past few weeks it has been known that negotiations have been pending with the Messrs. Hemingray of Covington, Ky., the object being to secure the location of an immense glass factory. We are glad to say that the negotiations have had a successful termination.

Mr. R. G. Hemingray, the junior member of the firm, has been in the city since last Friday. The company of which he is a member manufactures all kinds of fancy glass ware. They make table ware and fancy glass vases and in fact all kinds of elegant glass ware.

The company as it is now employs 500 people. The whole establishment will be moved here and will be much enlarged. It will be immense in every particular. The factory will be located on Macedonia Avenue --- just east of the Ball Bros. Glass Works. Mr. Hemingray says that work will be commenced on the factory immediately.

\*\*\*\*\*



THE MUNCIE DAILY NEWS

6 January 1888

Page 2, col. 1

\* \* \* \* \*

OUR LIST

Since the discovery of natural gas in Muncie the following factories have located, some of which are now in operation, some building, and others preparing to build:

FACTORIES.

Klunear Mfg. Co.....	100
Brooks Creamery.....	20
Ball Bros. Glass Co.....	300
Gustay Jenger Paper Co.....	200
Muncie Rubber Co.....	100
Hemingray Glass Co.....	500
E. P. Smith & Co.....	50
Thomson Enameling Works.....	125

This will give a total of 1,400 men which will have to be brought here in order to fill the demand. Most of the factories require skilled laborers, who receive high wages. Fourteen hundred families means an increase in population of seven thousand from the factory source alone. New stores are coming, which will bring new clerks and new proprietors. New carpenters and builders will have to come to erect the large number of factories already secured. Hundreds of houses will be built, besides new business blocks in various parts of the city. All in all before this time next year Muncie will have an increased population of 10,000 souls. Let the good work go marching on.

-----

Some time since the Marion papers gave vent to columns of wind saying that the Hemingray Glass Factory had been secured but alas they were doomed to disappointment. The fact is the gentlemen went to Marion and other places but found none so desirable as Muncie. The papers are all signed and everything is in shape to move forward.

-----

\* \* \* \* \*

THE MUNCIE DAILY NEWS

6 January 1888

Page 3, col. 3

\*\*\*\*\*

Mr. Hemingray, of the company who is to locate the new glass works here, leaves this evening for Pittsburgh, Pa., where he will order stuff that is necessary in the new plant. He says that if he finds the material that he needs in stock, the buildings can be commenced at once, if not the work will be delayed about 30 days. The main buildings will be either stone or iron. Of course the works of Covington can not be transplanted to Muncie in a day, but will be moved here in parts. In fact it will be about a year before the entire establishment will be placed in Muncie.

Another enterprise of moment that will be of interest to Muncie people is the Thompson Enameling Works. A gentleman who is in a position to know says that this is one of the most important enterprises that has moved to Muncie. They will make all sorts of enameled earthenware. Mr. Thompson, the gentleman who is to furnish the money for this enterprise, is from Evansville, Ind.

\*\*\*\*\*

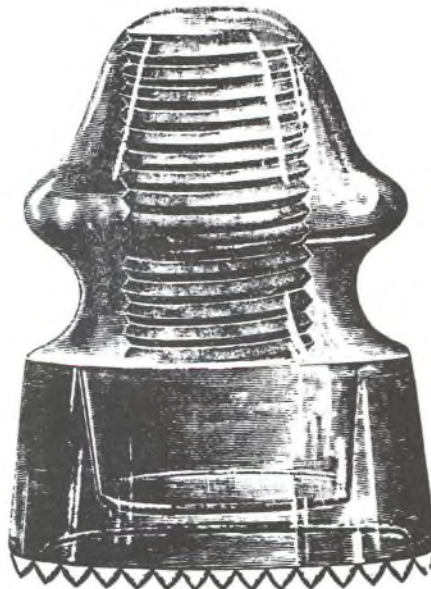

CD 164  
\$46.00 per 1000



MUNCIE DAILY TIMES

13 January 1888

Page 2, col. 2

\* \* \* \* \*

COVINGTON'S LOSS

The Hemingray Glass Company Moving  
To Muncie

-----oOo-----

Covington is about to lose one of the largest manufacturing establishments, the Hemingray glass company. Messrs. Robert Hemingray, Sr., and his son Ralph are now in Pittsburgh, contracting for the building of a glass furnace at Muncie, Ind.

They expect to get started about the middle of April, and will only make bottles at the start. About one hundred hands will be employed. The manufacture of their patent ware and lamps will still be done in Covington, as at present, and it will likely be a year before the factory will all be removed to Muncie, as their present plant is an extensive one.

The terms Muncie has offered the Hemingray Glass Company are liberal, and the facilities offered them are of the best. A gas well will be drilled on their premises, and the fuel furnished them free forever, or as long as there is any gas to be found in that vicinity. Mr. Ralph Hemingray will manage the new concern at present.

Muncie was not the only city that bid for these works. Toledo, O., made a liberal bid, as did Minneapolis, which offered them \$50,000 in cash and land to build on. Sandusky, O., made them an offer of \$20,000 in cash, ten acres of land and gas fuel free for three years, and at the end of that time at a cost of one-half the price Pittsburgh manufactures paid for gas.

The Hemingray plant in Covington covers several acres of land and the main building is three stories high. They employ several hundred men, and their pay roll averages about \$12,000 a month, when the factory is in full operation, which is ten months in the year. The most of the workmen's wages is spent in Covington. The new factory will, when completed, employ more men than their present one.

The Hemingray Glass Company first started in Cincinnati in 1848, the firm then being known as Gray & Hemingray. In 1852 the firm moved to Covington, and the firm name became Gray, Hemingray & Bros., afterwards R. Hemingray & Co., and in 1870 it was incorporated and changed to the present name, The Hemingray Glass Company. --- Cincinnati Times-Star.

\* \* \* \* \*

THE MUNCIE DAILY NEWS

13 January 1888

Page 4, col. 4

\* \* \* \* \*

NEW SWITCH LINES

W. W. Worthington, General Manager of the Ft. W. C. & L., accompanied by a civil engineer and his attorneys, was in the city this morning making arrangements for a series of switches, which, taken all in all, will be several miles in length. The switches are intended to reach the factories of the Hemingrays, Ball Bros., and the Muncie Flouring Mills. The main line of the switch will be from a point on the Ft. Wayne railroad just south of the city direct to the Ball Bros. glass works. The right of way has been given and the deeds were made today. The system of switches will be extensive. That is, they will be so arranged that all points of this property, now sub-divided, can be easily reached by short branches. The work on the switches will be commenced as soon as the ground will permit. Mr. John Wagner, the roadmaster, will arrive in a few days with a force of men, who will begin making the grade.

The Bee Line people are a little slow with their switches, but the prospects seem fair that they will build the roads now at an early date. The Bee Line people, who are rather stingy economists, are at last convinced that there will be enough business in the neighborhood of the Ball Bros. plant to warrant the building of half a dozen switches.

When this territory is traversed with good switches, giving easy access to our many railroads, it will be a much easier matter to secure the factories which we expect to locate here.

\* \* \* \* \*



CD 106  
\$20.00 per 1000



THE MUNCIE DAILY TIMES

18 June 1892

Page 1, col. 1-3

\*\*\*\*\*

OVER AND HEMINGRAY'S

-----

TWO BIG GLASS FACTORIES QUICK-  
LY GO UP IN FLAMES

-----

A Spark From a Railroad Engine Does  
the Fatal Work,  
Causing Over  
\$340,000 Damage.

-----

THE DELAY IN GETTING WATER  
FOR PROTECTION TOO LONG

-----

And Two of Muncie's Big Industries  
are in Ashes -- Three Hundred Per-  
sons Out of Employment.

-----

THE LONG EXPECTED CONFLAGRA-  
TION COMES AT LAST.

-----O-----

The Losses And How It Happened. Not one, but two of Muncie's big industries are in ruins and nearly 900 persons are out of employment. The Hemingray Flint Glass Factory, and the Over Window Glass Works are in ruins from fire. The total loss is estimated as \$340,000 with about \$116,000 insurance in companies principally represented by E. W. Bishop.

At about 9:45 a.m. the L.E. & W. Ry. belt switching crew were locating some cars for the Hemingray and Over glass works, on the switch that runs directly between the two factories, and by the side of a warehouse owned by the Hemingray factory.

One of the cars was loaded with a kind of straw used in packing glass ware, and a spark from the engine ignited it. The car was soon discovered on fire and the employes in the vicinity attempted to move it from near the sheds. The switch engine having gone it was impossible to move the car and the flames soon caught in the warehouse building on the south side of the track. At this juncture the alarm was given and Frank Ball of the Ball Bro.'s factory telephoned to the city department. Ball Bro.'s have an organized fire brigade which was called out and soon had their line of hose strung to the fire. The babcock chemical engine and the hose reel soon arrived but they were powerless with such a blaze raging and the short supply of water.

There was a strong north-east wind blowing and with the big Over factory on a direct line and but a hundred feet distant and the Hemingray factory immediately south it was evident from the start that both concerns would be wiped out. When the fire department arrived the warehouse near the burning box car was enveloped in flames which were reaching out as if anxious to get hold of the two big factories. It was not long until the heat was too great for the wooden and sheet iron structures, and both began to burn at the same time. The big buildings burned like tinder and soon an avalanche of black smoke was soaring high into the air quickly followed by flames that soon laid low both factories and all their valuable contents. With the assistance from the water power at Ball Bros. factory on line of hose was strung and succeeded in saving the office and one ware room building on the east side of the Hemingray factory, but the Over buildings were all destroyed and with them about all of the large amount of stock on hand.

The Hemingray works, which came from Covington, Ky., to this city, was one of the finest factories of the kind in the United States. Their machinery was of the very best, and their patterns the latest inventions. They manufactured principally bottles, telegraph insulators, and fancy glass globes. Very fortunately for them they had but a comparatively small amount of stock on hand. The following is the estimated detailed loss of the Hemingrays': On buildings, machinery and furnaces, \$90,000; on stock, \$20,000. Total, \$110,000. Insurance about \$40,000. The loss of the Overs' roughly estimated, as follows: Factory, buildings, machinery and furnaces, \$70,000; stock, \$60,000. Total loss, \$130,000, with but \$45,000 insurance.

It is poor policy to lock the door after the horse has been stolen, and it has been poor policy to wait until the city has sustained a loss of two or three hundred thousand dollars on this one and the Ball Bros., before the water mains are extended.

The city council and the water works company seem to be the ones most censured. Had there been available water for use as should have been, the two big concerns would have been saved. There was plenty time for action had there been anything to fight the blaze with. But there was not. The fire did not originate in a factory, but in a box car, then an old shed, and it took some time for the fire to reach the main building.

For a year or more the big factories of industry have howled long and loud for protection against fire. That part of the town has not been inside the corporate limits of the city and of course were not entitled to the protection of the city until a few weeks since. The gentlemen owning the big concerns objected to paying city taxes and that caused a division in the council as to extending the water mains for their own special benefit at the expense of the tax payers of Muncie. After the destruction of the stamp works about the last thing done by the old city council was to take Industry and the factory district into the city limits for protection, and the contract was made with the Water Works Company to lay a ten inch pipe line south on Macadonia avenue past the factories. The two factories burned were to have five hydrants, two each in their factories and one between the two.

The man sent here by the company to make the extensions was urged to first build the Macadonia line to the factories by the factory people, and work was begun there first. The ground is very low in that locality and the constant rain last month caused work to be stopped before completed to Industry, and



since then the men were at work in another locality, when, it is claimed, that the Macadonia line should have been pushed to completion. Superintendent Walling of the Water Works Company stated that he had nothing to do with the extension work. The company is under contract to have the extension made and completed by August 1st and had a man here in charge of the work, and if the recent heavy rains had not interfered the Macadonia line would have turned water into the line and saved the building.

The city fire department had about all their hose at the scene and did good work so far as possible with the one line of hose.

The Over factory is one of the oldest glass concerns in the city and it was a well established factory. Two weeks hence the factory was to close down for the summer season. The establishment manufactures window glass, a large supply of which is always on hand at this time of the season and this is no exception, making that gentleman's loss very serious.

The insurance on the Hemingray building and stock distributed among the following companies: Norwich Union, \$2,000; Manchester, \$2,750; Lancashire, \$3,000; British America, \$1,500; St. Paul Fire & Marine, \$2,500; North British Mercantile, \$1,250; Springfield, \$1,000; Michigan Fire & Marine, \$1,500; Imperial, \$2,000; Hamburg-Bremen, \$1,100; Traders, \$2,500; Sun Fire Office, \$2,500; Evansville, \$2,000; State Investment, \$1,000; Western, \$2,000: Total \$31,500.

Over's property was insured as follows:

British America, \$2,000; Niagra, \$1,500; Sun Fire Office, \$2,750; Manchester, \$2,000; Norwich Union, \$2,000; Michigan Fire & Marine, \$1,500; North British Mercantile, \$2,000; Fireman of Baltimore, \$1,200; Western of Toronto, \$1,500; Traders, \$2,000; German of Peoria, \$1,000; St. Paul Fire & Marine, \$1,250; Lancashire, \$2,500; Imperial, \$2,000; Home, \$2,000; Imperial, \$2,000; Evansville, \$2,000; Calidonia, \$1,000; Springfield Fire and Marine, \$1,000; Indiana Underwriters, \$2,000; Indiana Ft. Wayne, \$1,000; Scottish Union, \$1,500; Hamburg-Bremen, \$1,100; State Investment, \$1,000. Total \$43,300.

#### NOTES

It was a close call for some of the dwelling houses in the vicinity of the fire.

Rush the water works extension and give us one or two more fire stations at once.

The furnaces at the Over factory are not a total wreck, one of them is but slightly damaged.

Over's factory was employing about 125 hands and the Hemingray's a larger number.

Hundreds of people from the city were soon on the ground, viewing the progress of destruction.

While the losses will greatly aggregate the insurance both the factories will be rebuilt and in running order in a few months.

The men employed in the factories and many of them at Ball Bros. braved the heat and worked nobly to save what they did.

Messrs. Over and Hemingray wish the Times to thank the gentlemen who worked so faithfully in the effort to save the stock.

Five loaded box cars burned, two were loaded with sand consigned to Hemingrays, two with lumber for Overs', and one car with straw for Hemingrays' which caused the fire.

The insurance on the Hemingray glass factory was increased \$3,000 last week by K. W. Bishop, who controls the insurance in Muncie or nearly all the companies interested.

Walter, son of Hon. R. S. Gregory, organized about fifty boys who did noble relief work carrying drinking water in fruit cans to the men who were fighting the flames. It was a novel idea for the little boy.

The Hemingray glass people have begun clearing away the debris and will at once rebuild. A shed will be constructed over the large furnace which is not injured and the blowers have been instructed to report for work Monday morning.

\*\*\*\*\*

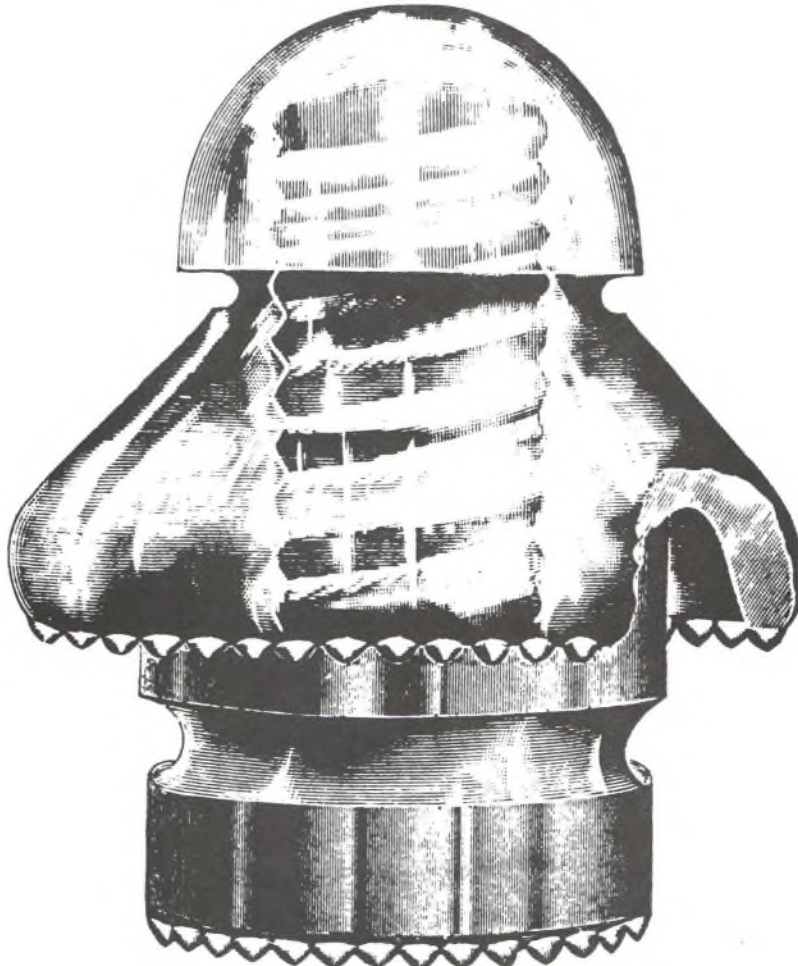

CD 196  
\$136.00 per 1000



THE MUNCIE DAILY NEWS

18 June 1892

Page 1, col. 2-4

\* \* \* \* \*

\$250,000

-----

GO UP IN SMOKE IN  
ONE HOUR

-----

The Hemingray and Over  
Glass Houses

-----

BURNED TO THE GROUND

-----

A Spark From A Lake Erie  
Switch Engine

-----

Starts the Big Fire

-----

THE WATER WORKS JUSTLY CON-  
DEMMED FOR NEGLIGENCE

-----

Insurance is About \$75,000.

-----

Both Factories Will be Rebuilt This  
Summer. -- The Fire Department  
Almost Helpless to Lend Aid.

-----O-----

A little spark from a switch engine. It drops into a little heap of straw.

In ten minutes two immense factories are in flames and in one hour both are in ashes.

Three hundred men are out of employment, and the owners see over a quarter of a million dollars go up in smoke.

The fire department get there on time, considering the long distance, but without plenty of water are powerless.

Briefly this tells the tale of one of the most disastrous fires that ever visited the city of Muncie. At the Hemingray and Over glass works, where this morning 300 men were at work, nothing but a pile of ruins exist.

#### How it Started.

At just 10 o'clock the Lake Erie switch engine was standing between the Over and Hemingray glass works waiting for a car load of glass to be sealed. The fireman threw in a couple of shovels of coal and stirred up the furnace.

This sent a shower of sparks high into the air; one fell into a pile of straw and in but a few seconds the packing room of the Hemingray factory was in flames.

Bob Hemingray at once telephoned for the City department and the entire apparatus of the Ball Bros. was being brought into use.

The hose from Balls would not reach the factory. The flames spread rapidly, being fanned by a

#### South West Wind.

And it was but a few minutes until the flames were going through the Over window glass factory.

#### A Short Story.

The story was a short one. In less than an hour every building, warehouse, packing room and furnace of the Over glass works was in ruins. The Hemingray factory was not far behind for their fine foundry and machine shops, which have no equal in any glass house in the west, warehouses, and everything except one warehouse and the office, was charred boards and a ruined wreck.

No one ever saw a quarter of a million dollars burn quicker, and where the hundreds of the people around were so helpless.

The water at the Ball works was all that could be secured, and that came too late to be of any use in getting the fire under control. While this one stream did an immense amount of good, saving a few thousand dollars worth of property, that simply illustrated what the department would have been able to do had they had plenty of water where it could have been used at once.

#### The Loss.

As near as can be calculated, on a rough estimate, after talking with the two proprietors of the large industries, the loss will run about as follows:

Hemingray: stock \$20,000, factory, packing-buildings, ware-rooms, machine shops, tools, etc., \$90,000, making a total of \$110,000. On this great loss they had but \$31,500 insurance, the distribution of which is given below.

The big ten pot furnace at Hemingray's in not considered to be injured, at least to any great extent.

The loss at Over's will be about \$130,000; they having nearly \$60,000 of window glass all boxed and ready to ship, while the factory, furnaces, and general glass house material was valued at about \$70,000.



Their insurance was \$43,300. A few hundred dollars worth of stock was saved, aside from which the entire industry was a total loss.

The insurance was as follows:

On Over's Factory and Stock

British America, 2000.  
Niagra, 1500.  
Sun Fire Office, 2750.  
Manchester, 2000.  
Norwich Union, 2000.  
Michigan Fire & Marine, 1500.  
Fireman's Baltimore, 1200.  
Western of Toronto, 1500.  
Trades, 2000.  
German of Peoria, 1000.  
State Investment, 1000.  
St. Paul Fire & Marine, 1250.  
Lancashire, 2500.  
Imperial, 2000.  
Home, 2000.  
North British & Mercantile, 2000.  
Imperial, 4000.  
Evansville, 2000.  
Calidonia, 1000.  
Springfield Fire & Marine, 1000.  
Indiana Underwriters, 2000.  
Scottish Union, 1500.  
Hamburg-Bremen, 1100.  
On the pot house at Overs by the Reading, 600.

Insurance at Hemingray's.

Norwich Union, 2000.  
Manchester, 2750.  
Lancashire, 3000.  
British America, 1500.  
St. Paul, 2500.  
North British Mercantile, 1250.  
Springfield, 1000.  
Michigan Fire & Marine,  
Imperial, 2000.  
Hamburg-Bremen, 2000.  
Traders, 2500.  
Sun Fire Office, 2500.  
Evansville, 2000.  
State Investment, 1000.  
Western, 2000.

Cussing the Water Co.

The losers had a grand kick coming on the water company, and they were not very slow in saying just what they thought.

Many months ago the city ordered water mains on Macedonia Avenue, together with miles of other mains. The two doomed glass factories had ordered the five extra hydrants put in for the protection of their plants, and had asked the managements of the water company to lay the Macedonia line as quick as possible. Some of the city officials had tried to get this line laid, but they were unsuccessful, the water company preferring to lay the mains out in the suburbs where they will probably never be needed.

Why this obstinacy on the part of the management, no one can say but it was the means of losing Muncie two large factories, for there is no doubt but that with water protection at hand, the Over factory would have been damaged but little and but one of the Hemingray ware houses would have been consumed, but as it is, everything is lost. We suppose that now the water works people will just make things fly to get in that line.

With the hose they had at hand, and with hydrants handy, as both Hemingray and Over had them ordered, the fire would never have spread, as every member of the fire department knows, but as it was they were powerless.

#### Cars Burned.

Several freight cars were burned, but just how many could not be learned. There were two cars of sand, for Hemingrays, one car of shucks, two of lumber, all received this morning; one car load of insulators ready for shipment, and several empties ready to load. Many of these could have been saved by the train crew if they had went after them.

#### May Rebuild.

Dr. A. R. Smith, the Secretary of the Over company, stated that he did not know whether they would rebuild or not, it being too early yet to talk about that. They had the largest stock in the ware house that they before had on hand, which made the loss exceedingly heavy on them.

While it is very probable that the Over factory will be rebuilt, yet nothing certain can be given in regard to that at this time.

#### Will Lose No Time.

Bob Hemingray was here at the fire, and took affairs as coolly as anyone could under the circumstances. Ralph is at Covington, but was wired that the entire factory had gone up in flames.

Bob said that they would commence at once to rebuild. The furnaces are uninjured, and as the Hemingray's have a large contract on hand for insulators for the Western Union, they can afford to loose no time.

Already this afternoon they are cleaning away the rubbish.

Tomorrow a temporary shed will be erected and on Monday they will commence to make glass and push the work just as fast as it is possible for them to.

The entire factory will be rebuilt this summer. The Hemingray's had the finest machine shop of any glass factory in the west, making all of their own moulds, etc. The loss in this department is very large.

#### Season Nearly Over.

The fires would have gone out at both factories on June 30, there being but ten days more for the men. Should they rebuild, which is probable, all will be ready to start by September with the fall fires.



Notes of the Fire.

Joe Cheesman was the first man to give an alarm.

All the water used came from Ball Bros., and was a great help.

Overs had intended to build a large brick warehouse this summer.

Harry Richey was on hand as common doing valuable work for the department.

The employees worked hard to save all the stock possible from the Over ware house.

Chat Taylor, of the fire department got his full share of the warmth that was so abundant.

Chief Shepp did everything that was possible, the fire was just more than they could handle.

Insurance companies do not like glass house risks, which is the cause of the insurance being so small.

While the buildings were all in flames Bob Hemingray announced that he would make glass next Monday.

Martin Shafer had finished a ware house for Hemingray last week. That was their only building that escaped.

The water company is receiving plenty of just criticism for leaving the Macedonia extension, the most important one ordered, until last.

The chemical was kept busy dodging around among the dwellings keeping them from burning. The home of Tenny Kieckner was on fire several times.

This will be the expensive lesson that will bring us more fire stations and a better fire department. It takes a pretty expensive lesson to learn the council what we need.

\* \* \* \* \*

THE DAILY HERALD

18 June 1892

Page 2, col. 2,3

\* \* \* \* \*

GREAT CONFLAGRATION

-----  
Hemingray's Bottle  
Works, and Over's  
Window Glass Fac-  
tory Burned to the  
Ground

-----  
The Loss will Aggregate  
Nearly Two Hun-  
dred Thousand  
Dollars

-----  
The Costliest Fire Ever  
Muncie Experienced

-----  
Three Hundred Persons  
Thrown Out of Em-  
ployment

-----  
The Fire Originated By  
a Spark From a  
Locomotive

-----  
Hemingray and Over's glass houses are destroyed by fire.

On account of water mains not being extended to near the fac-  
tories the fire department was of little benefit.

The loss will amount to nearly \$200,000 which is partly cov-  
ered by insurance.

Owners of both establishments will commence at once rebuild-  
ing.

It was fortunate for the employes that the fire occurred  
when the closing season was near at hand, or a great hardship  
would have been brought on them.

The greatest conflagration ever Muncie experienced.

The window glass house of Chas. H. Over and the bottling man-



ufacturing establishment of Hemingray's are located near each other on the southeastern part of the city, off of Macedonia avenue. The two concerns cover several acres of ground and give employment to about three hundred hands.

Messrs. Hemingray came to Muncie from Covington, Kentucky, five or six years ago, while Mr. Over came a short time afterwards from Bellaire, Ohio.

Both have prospered in the glass business and have added largely to their respective plants until their establishments had grown to be the largest in the city.

It was about 10 o'clock this morning when an L. E. & W. switch engine was doing some switching of cars on the tracks that lie between the two factories. Six cars were left standing on the tracks after the crew had finished their work. The engine had not left the factories more than a minute when fire was discovered in one of the storage rooms belonging to the Hemingrays. Several persons saw the fire at this time, all of whom say it was caused by a spark from the locomotive, but the engineer and fireman and switching crew claim that they had been gone several minutes before the blaze was discovered, but be this as it may there is no question but two of Muncie's best glass industries are reduced to ashes, entailing a loss of thousands of dollars.

A telephone message was sent Chief of Fire Department Shapp to hasten with plenty of hose, which was done, and he also sent the chemical engine, but neither were of much benefit, as the buildings were enveloped in flames and the fire rapidly spreading before their arrival. As the water mains are not extended farther than the nail mill, the fire department could do but little in saving the buildings.

From the storage room the fire swept like a cyclone to the packing rooms, shop, and finally reached the factory proper, where it required but a short time to lay it all in ashes.

After playing havoc in this direction the wind changed its course to the northeast, which fanned the fire into a rolling mass of flames like the mighty waves of the ocean when a great tempest is raging, destroying everything in its path and laying to waste the accumulations of labor, the red demon crept on until the window glass house of Mr. Over was reached, and in an

hour's time it also was burned to the ground.

All that the hundreds of spectators could do was to stand off and look on while the fire did its work of destroying the property. The employes gave expression to their sorrow at their employers by standing in groups and talking to themselves.

With the exception of two or three small buildings belonging to Messrs. Hemingray, everything in the locality was burned to the ground.

The loss is a great one, not only to the owners, but to Muncie as well.

The HERALD is informed that Messrs. Hemingray have decided on not rebuilding, and will return to Covington within a few weeks.

During the progress of the fire some unknown person went into Over's office and took from the safe \$2,000 in money.

The following is the insurance.

OVER.

Hamburg Bremen.....	\$ 1,100.
British America.....	2,000.
Niagara.....	1,500.
Sun.....	2,750.
Manchester.....	2,000.
Norwich Union.....	2,000.
Michigan Fire & Marine.....	1,500.
North British and Merchantile.....	2,500.
Fireman's.....	1,200.
Western.....	1,500.
Trader's.....	2,000.
German.....	1,000.
State Investment.....	1,000.
St. Paul Fire and Marine.....	1,250.
Lancashire.....	2,500.
Imperial.....	2,000.
Home.....	2,000.
Imperial of Calcutta.....	4,000.
Evansville.....	2,000.
Caledonia.....	1,000.
Springfield.....	1,000.
Indiana Underwriters.....	2,000.
Indiana, of Ft. Wayne.....	1,000.
Scottish Union.....	1,500.
Reading (Pot House).....	600.
	-----
Total.....	\$43,900.

HEMINGRAY

Indiana Underwriters.....	\$ 1,500.
Norwich Union.....	2,000.
Manchester.....	2,750.
British America.....	1,500.
St. Paul Fire & Marine.....	2,500.
North British.....	1,250.
Springfield.....	1,000.
Michigan Fire & Marine.....	1,500.
Lancashire.....	3,000.
Imperial.....	2,000.
Hamburg-Bremen.....	1,500.
Traders.....	2,500.
Sun.....	2,500.
Evansville.....	2,000.
State Investment.....	1,000.
Western.....	2,000.
	-----
Total.....	\$31,000.

\* \* \* \* \*



THE MUNCIE DAILY TIMES

20 June 1892

\* \* \* \* \*

FROM ANOTHER SOURCE

-----  
THE L. E. & W. SWITCHING CREW DENY THE CHARGES  
-----

They Say the Fire First Started in the  
Warehouse and Was Not Caused By a Spark  
From the Engine -- Interesting Notes of  
Big Blaze.  
-----

A Times man was among the hundreds of people who visited the scene of Saturday's great conflagration which destroyed the Hemingray and Over glass factories. In the crowd present was Charley Yeager, a well-known citizen residing on Seymour street and for many years employed in the L. E. & W. switching yards. Charley is under the instructions of yardmaster Charley Weis of the belt crew who was at work near the burned factories when the fire started. In talking to the Times man Mr. Yeager emphatically denied the general report that a spark from the engine started the fire. He said that he was one of the first to discover the fire and it was then raging in the Hemingray ware room. They had just set some cars on the Hemingray siding and noticing the danger of the cars, an effort was made to get them out but when the engine was shifted on the track the fire had spread to the cars and they could not be attached. The cars were on an incline and the blocks of wood were knocked out from under the wheels but a single break held them and the seven cars were burned. All were L. E. & W. cars but one, L. S. & M. S. One car was loaded with lime for Over but had not yet been delivered and the company is the loser. Another car was loaded with insulators and was ready for shipment to Chicago by the Hemingrays. A car load of sand for Mack Bros., brick manufacturers was also in the bunch.

But one or possibly two the Over ovens were saved, the others will have to be rebuilt.

Photograph Arrasmith was on hand yesterday and photographed the ruins at the request of several of the employees.

Mr. Over states that the reporter for another paper was in error in stating that \$2,000 had been stolen from the office safe.

Much of the molten glass at Overs can be used as "cullet" which is very necessary in glazing new pots and a great deal of it can be worked over.

Harry Dwyer employed at the Hemingray factory lost a coat that some person took by mistake. Leave the garment at the Hemingray office.

The swing hole and cave and the pots in the furnaces at Overs were not damaged and probably two car loads of glass was saved.

Jake Gillenwater was at work at the Hemingray factory yesterday keeping the big furnace heated up. The furnace represents several thousand dollars and is uninjured.

The nerve of some people was demonstrated during the fire. One of Hemingray's employees approached treasurer Robert Hemingray and demanded his money. He got it.

Martin, son of Leroy Carey, a small carry-out boy, aged twelve, employed at Hemingrays had a close call from being cremated. The lad had gone in the shed and lay asleep near where the first fire started. Some men remembered seeing the boy dragged him out just in time.

After the fire had worked destruction the rain came which prevented the Hemingrays from starting work this evening as they had expected to. The half dozen ovens were not injured until the rain fell on them and caused a general collapse of five out of the six and work will not be commenced to-day, but Mr. Hemingray has notified his patrons that the factory will be rebuilt and in full blast within sixty days.

\* \* \* \* \*

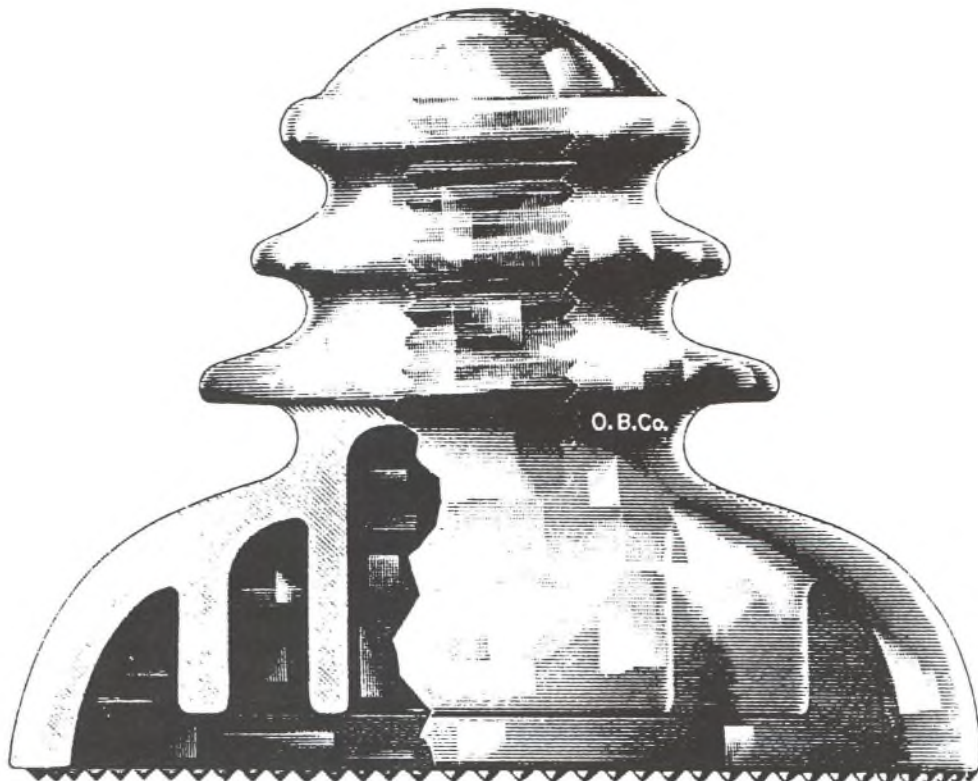

CD 283  
\$360.00 per 1000



THE MUNCIE DAILY NEWS

20 June 1892

Page 5, col. 3

\* \* \* \* \*

AROUND THE RUINS.

-----

Hundreds of People Visit the  
Wrecked Glass Houses.

-----

The Insurance Adjustors Will  
Come Immediately.

-----

LAKE ERIE CARS BURNED.

-----

Both Plants Will Be Rebuilt  
During The Summer.

-----

FURNACES UNHINDERED

-----

Hard Work to Keep People  
From Taking Everything  
Loose. --- Notes Gathered  
at the Fire Scene.

-----

Hundreds of people visited the ruins of the Hemingray and Over glass works Sunday. The place was indeed a most dismal and desolate one. Tire could not have made a much cleaner sweep than it did around these two thriving industries.

Aside from one or two ware rooms and small buildings of Hemingray's, the entire place is one mass of burned and charred ruins, twisted pipes, old iron and glass, glass everywhere.

At the Over works the blow furnace is not thought to be injured in the least; the two melting furnaces are still standing and the fires were not allowed to go out, so unless they were cracked by the intense heat, they are not damaged.

Lew Over smiled as he looked into the "swing holes" and saw that these excavations had not been destroyed. The caves did not fall in.

The Hemingray furnaces are all right. They had intended to commence to make glass tonight, but the rain Saturday caused the

tempering ovens to fall in, so that it is doubtful whether they can commence. If matters can be arranged, work will be commenced at once.

All the machinery in the machine shops is ruined, unless it is the boiler.

There were seven cars burned, six Lake Erie and one L. S. & M. S. The car of sand was for Mack Bros., and will be the railroad's loss. The car of lime was for Over's but not having been delivered on their siding will be a loss to the railroad also.

#### Trainmen Hot.

The train crew that were out there switching do not think the fire started from their engine. They claim that the fire started in a shed at the far end from the track.

The spark theory is still held by the employees around the Hemingray packing sheds.

Conductor Wetz, who was in charge of the train, says that it was impossible to save the cars that were destroyed, the fire getting under headway in such a short time.

#### Rebuild at Once.

Mr. Over stated to a Newsman that as soon as the insurance people arrived, that they would commence to clean away and get ready to rebuild, and the new factory would be ready to start the fall fires.

Their loss of stock is very large, and will fall very heavy on the factory, but with all that the enterprising proprietors will take up the reins and start at it again.

Ralph Hemingray arrived home from Covington Sunday. He said that in one hour after the adjustors were through, they would have a force of men at work cleaning up, and the factory would be re-built more complete and better than before by Sept. 1.

#### Pilfering - Sight-Seers.

It took a dozen men busy to keep the people from carrying articles of value, and damaged material and tools away. All will be needed when the insurance people arrive. It does look like people should sympathize with the owners in their loss, rather than try to acquire some of the small portion left.

#### The Scene Photographed.

A. G. Arrowsmith was on the ground Sunday and took a photograph of the ruins. Many of the old employees wanted a picture of the wreck to keep.

#### Now For Water.

Now for water in the reach of every factory possible. The citizens raised a large fund to bring in the factories, so it is due those tax-payers that the city do everything possible for their preservation. Run the professed mains to factories at once. Put in another fire station and let us do our part to keep them from burning down.



In the last few months it has been twice said "lock the door after the horse is stolen." Let the council remember that there are more horses, so for goodness sake erect the doors and put on a few locks.

\*\*\*\*\*

THE DAILY HERALD

20 June 1892

Page 3, col. 4

\*\*\*\*\*

Will Rebuild

The HERALD was misinformed Saturday in regard to the Messrs. Hemingray not going to rebuild their glass factory. They have already commenced clearing the debris away for a new building, and before the next fire everything will be in readiness for the men to go to work. As the pot was not damaged a temporary shed has been erected around it and the blowers are turning out bottles at a lively rate.

Mr. C. H. Over expects also to have another factory erected by the first of September.

\*\*\*\*\*

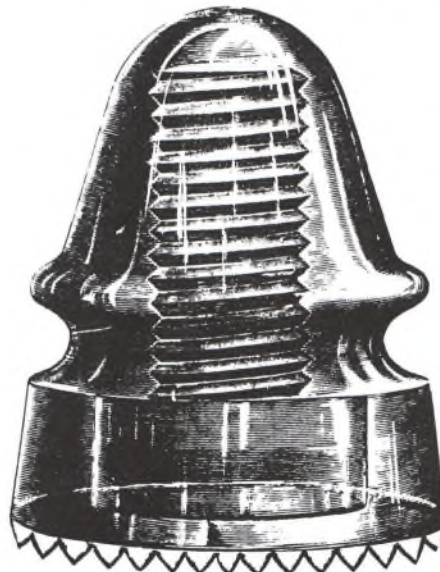

CD 162  
\$46.00 per 1000

THE MUNCIE DAILY TIMES

22 June 1892

Page 4, col. 3

\* \* \* \* \*

FACTORIES AND MILLS.

-----

SOME LOCAL NOTES OF AN INDUSTRIAL CHARACTER

-----

Muncie's Many New Industries Fast  
Getting Ready for a Great Increase in Business

-----

In the past few days Muncie has lost two valuable industries by fire, but fortunately both will rebuild at once. The Hemingray concern is in operation on a small scale, and as soon as the insurance men do the right thing, their new building will cover the burnt district. Mr. Over is unable to do any work until his new factory building is erected but that will be the time of starting the next fire in September.

Workmen commenced to remove the debris of the old armory building this morning.

Charles A. Cashdollar and Thomas Abor of the Over factory departed last evening for Pittsburg.

. . . . .

Work on the Hemingray factory is going on. A shed has been erected around the furnace and a half dozen or so men are at work with their pipes.

. . . . .

Just as soon as the insurance adjusters have finished their work and a settlement is made Mr. C. H. Over will commence rebuilding his factory which will be a much better structure than the one destroyed by fire.

\* \* \* \* \*



THE MUNCIE DAILY TIMES

24 June 1892

Page 1, col. 4

\* \* \* \* \*

Losses Being Adjusted

For three days past agents of the several insurance companies which sustained losses by the burning of Over and Hemingrays' glass factories have been at work adjusting the losses. The loss in the wareroom at the Over factory amounting to \$34,000 has been adjusted the full amount on insurance on which, between \$22,000 and \$23,000, will be paid. In the factory was a large amount of fine glass on which some insurance was carried. The companies seem disposed to deal fairly and the losses will shortly be amiably settled.

\* \* \* \* \*

THE MUNCIE DAILY NEWS

24 June 1892

Page 1, col. 4

\* \* \* \* \*

SWEAT! SWEAT!

-----

Work and Then More Sweat is the  
Order

-----

WHAT FACTORIES ARE DOING

-----

The Gill Brothers' Pot  
Factory Now Working

-----

Gill Brothers pot factory is now working full force turning out the clay pots for glass works. The room are large and commodious, being 100 X 200 feet, and the machinery rooms 75 X 36. The company make nothing but clay pots for the glass works and large clay brick also need in constructing a furnace. So exact is the work of constructing a pot, that should a small stick or thread get into the clay the whole pot would be spoiled. Some break and crack during the drying process and are torn down to be worked over again. The work of manufacturing a pot is all

hand work and requires considerable skill. The factory is now working in the neighborhood of 50 hands. A large engine is placed in to run the clay crushers and other different machines used in the process. The clay used comes from Missouri and Germany.

-----

Fifteen hundred feet of new hose have been purchased since the water works is to be extended past the factory.

-----

Mr. and Mrs. John Sullivan will leave for Covington, Ky., tonight where they will visit with friends. Mr. S. was employed at Hemingray's.

-----

On Thursday next the fires go out in all of the glass factories for the entire heated term. The shut down will last for two months. A great majority of the boys will visit the summer resort and former homes.

-----

The losses in the recent fire are being adjusted today. The work will not be completed until next week.

\* \* \* \* \*

THE MUNCIE DAILY TIMES

27 June 1892

Page 3, col. 3

\* \* \* \* \*

MUNCIE NOTES

-----

We have also had the pleasure of meeting the old pioneer manufacturer, Mr. Robert Hemingray, and since his golden wedding he seems to have gotten younger, and he wishes to express special thanks through The Commoner and Glassworker to the employees of the factory for their kind remembrances to him on the occasion, and we hope, with his many friends, that he may be able to celebrate his diamond wedding, and give The Commoner and Glassworker a bid.

\* \* \* \* \*



THE MUNCIE DAILY NEWS

29 June 1892

Page 1, col. 4

\* \* \* \* \*

MUNCIE'S GLASS PROSPECTS.

-----

What will be Accomplished By the  
Next Fire

-----

CONTINUOUS TANK FURNACES

-----

The Burned Factories Will Be  
Rebuilt. -- A New One Added to  
the List of Old Ones.

-----

Tomorrow evening the fires in the glass works, both window, flint, and green houses, go out to give the blowers their regular summer vacation. The furnaces will be idle for two months, at the end of which time a marked difference will be noticed in the glass trade of this city. As it now is we have but the factories of Ball Brothers, Maring, Hart & Co., the Muncie Glass Co., in operation. The works of the Over Window Glass company is in ashes, as is also the flint house of the Hemingray boys. When the fires are lighted in September the works of the two last named will again be in operation with an increased capacity, and the factory proposed for the manufacture of the R. I. Patterson patent fruit jar will be numbered among the new factories. The doubling of the capacity of the Maring, Hart & Co., works will give that place a working force of nearly 400, instead of 200. Ball Brothers are now at work on their extensions which will add about 150 workmen to their force. Surely the glass industry at this place is of no mean proportions. With the starting of the next fire 1,000 additional people will be added to this city.

\* \* \* \* \*

THE MUNCIE DAILY TIMES

30 June 1892

Page 1, col. 3

\* \* \* \* \*

AMONG THE FACTORIES

-----

GENERAL NOTES

Since the fire the Hemingray factory have turned out two car loads of glass insulators and are still at work on pressed ware, giving employment to about forty hands.

\* \* \* \* \*

THE MUNCIE DAILY TIMES

30 June 1892

Page 1, col. 3

\* \* \* \* \*

GENERAL NOTES

The wife of Ralph Hemingray, who is quite sick at Cincinnati, is slowly improving.

\* \* \* \* \*

Page 1, col. 4

\* \* \* \* \*

Will Rebuild Larger Than Before

Last evening Mr. Ralph Hemingray stated to a Times man that as soon as the insurance on their factory was adjusted a large force of men would be put at work clearing away the debris and the erection of a much better plant than the one burned would be commenced. For vim, vigor and push the Messrs. Hemingray are right in the front.

\* \* \* \* \*



THE MUNCIE DAILY TIMES

8 July 1892

Page 1, col. 4

\* \* \* \* \*

FACTORY AND MILL  
ITEMS OF INTEREST GATHERED  
FROM MANY QUARTERS

-----

Work on the Burned Factories  
to Begin at Once.

-----

The Hemingray Glass Company here decided upon rebuilding their glass factory. They will not let the contract for the erection of the buildings, but Robert Morgan, a contractor in their employ, will have charge of the work. Last evening Mr. Morgan ordered the lumber and active work on the main structure will commence by next Wednesday.

The factory when completed will be larger than before and much more convenient. The main structure will be 70 X 170 feet, 22 feet to the square, with circular top, a 20 foot spring, and large ventilator, there will be a tin works 40 X 60, machine shop, stock room, moulding room, and carpenter, cooper and box shops.

The buildings are to be of corrugated iron and the Hemingrays will have a finer factory than the one lost by fire.

\* \* \* \* \*

THE MUNCIE DAILY TIMES

27 July 1892

Page 1, col. 4

\*\*\*\*\*

THE HEMINGRAYS

-----  
WILL MOVE ANOTHER PART OF  
THEIR PLANT FROM COVINGTON.  
-----

The Works to be Operated in Con-  
nection With the Muncie Factory \*\*  
Other Factory Notes \*\* Personals.  
-----

Not only are the Hemingray glass company rebuilding their burned factory, but in addition a new building is being erected to be occupied by a part of the company's plant now operated in Covington, Ky.

The tin works manufacturers tops for candy jars and other glassware, as well as a side lamp of tin. The prosperity of the firm, notwithstanding the disastrous fire, has induced them to remove the Covington machinery to Muncie and it will add several hands to the large number already employed here. The decision of the company will bring several more families from Covington to the metropolis of the gas belt.

\*\*\*\*\*

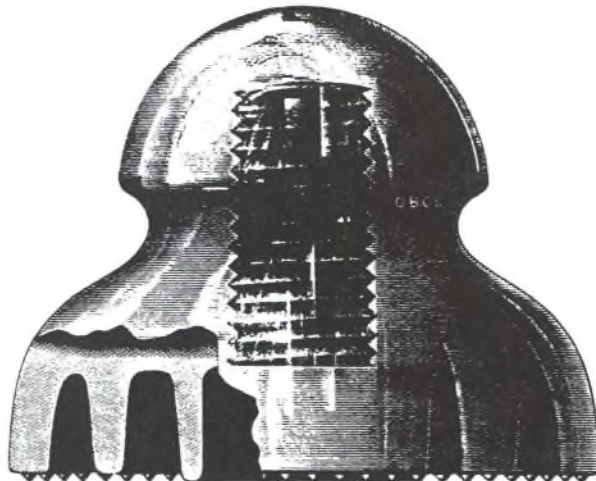

CD 280  
\$132.00 per 1000



THE MUNCIE DAILY TIMES

20 January 1897

Page 1, col. 3

\* \* \* \* \*

IN MEMORY OF '76

=====

DAUGHTERS OF THE AMERI-  
CAN REVOLUTION

-----

A Muncie Chapter Organized With  
Twelve Charter Members and  
Officers Elected

-----

A Muncie chapter of the Daughters of the American Revolution was formed yesterday afternoon at the Kirby House with twelve charter members under the direction of Mrs. Chapin C. Foster, of Indianapolis, state Regent of the society.

The twelve ladies have held certificates of individual membership for some time and have been endeavoring for months to organize into one body, with the results that yesterday afternoon the state chapter in Indiana, was formed. The charter members of the chapter are Mrs. John F. Wildman, Mrs. Thad A. Neely, Mrs. Will Marsh of Indianapolis, Mrs. Julia A. Heinsohn, Mrs. Edward Glass, Mrs. Robert Hemingray, Mrs. James E. Durham, Miss Suzette Kirby, Misses Nannie and Edith Love, and Misses Eila and Lanra Dailey.

Officers were elected as follows: Regent, Mrs. Heinsohn; Vice-regent, Mrs. Hemingray; secretary, Mrs. Durham; treasurer, Mrs. Neely, and registrar, Miss Nannie Love. Souvenirs of small silk American flags were presented to the members. After the installation a dainty collation was served. The chapter will meet once a month at the homes of the members.

The purpose of the order is to preserve the memory of the brave men and also the women who won freedom and liberty for this country during the heroic war of 1776, and also to instill more patriotism, love and loyalty to one's country, if possible, in the present and future generations. Only those who are in direct lineage from some one who fought on the American side in this great war and can furnish proof of same can be members. At present there are 13,000 members in the country and about 200 in Indiana. There are no doubt thousands of descendants of the "boys of '76" in Indiana, but the difficulty is in proving the same, very few ancestral trees being complete as far back as that. A number of other Muncie ladies who believe they can become members of the order are working on their proofs and expect to soon be able to join.....

\* \* \* \* \*

THE MUNCIE DAILY TIMES

24 February 1897

Page 1, col. 4

\*\*\*\*\*

YOUNG ELKS ORGANIZE

-----

Personnel of Their Base Ball Club New  
This Season

-----

The Young Elks' Base Ball Club has been organized for this season as follows: C, Ray Palmer; p, Red Murray; s.s. Will Haymond; 1 b, Zora Clevenger; 2 b, Charles Gill; 3 b, John Beuta; r. f., Herb Johnson; c. f., Bob Scott; l. f., Con Hemingray. The boys are all sons of members of Muncie lodge of Elks.

\*\*\*\*\*

THE MUNCIE DAILY TIMES

29 September 1897

Page 1, col. 2

\*\*\*\*\*

A CLOSE CALL FROM DESTRUCTION

-----

A Fire at Hemingrays' Glass Works Nipped in the Bud

At 10 o'clock this morning Hemingrays' glass works in Industry had a close call from destruction by fire. Sparks from a Big Four switch engine ignited a pile of old sacks which were lying close to the side of the mixing room. The sacks are very combustible and the flames once started spread with great rapidity and communicated to the wall of the mixing room which is a frame structure. The factory force laid two lines of hose and had the flames extinguished before the fire department, which had been summoned, arrived. The loss was very slight but still the factory had a narrow escape from destruction.

\*\*\*\*\*



THE KENTUCKY POST

28 June 1898

Page 3, col. 5

\*\*\*\*\*

START MADE.

-----

The Covington Glass Com-  
pany Is a Go.

-----

The Old Hemingray Plant To Be  
Running by Sept. 1.

The Covington Glass Company is a go. Tuesday workmen began getting the old Hemingray glass plant, at the foot of Madison Avenue, in shape for the manufacture of glass goods.

The company expects to start manufacturing about September 1, and will employ not less 60 hands. Sam Brown, a former employee at the Hemingray Company, is the manager of the new concern.

\*\*\*\*\*

THE KENTUCKY POST

28 September 1898

Page 4, col. 3

\*\*\*\*\*

NEW COMPANY

-----

to Manufacture Lamps -- Burgoo in  
Honor of the Event.

Colonel H. H. Hardy entertained a number of his friends with a burgoo Tuesday evening. The occasion was in honor of the formation of a new company to manufacture an incandescent lamp, an invention of Mr. Hardy. The company has secured quarters in the Hemingray Building, at Second and Madison Avenue, and will start up at once. Those present at the burgoo were Messrs. William Riedin, Dr. James Wise, H. F. Farney, Theodore Hallam, Henry Queen, Frank Dorsel, John Dorsel, William Hughes, Thomas Galvin, Michael Galvin, Colonel Bob Crigler, Hon. M. Abele, A. R. Mullins, Henry Tarvis, Dr. J. C. Terrill, Henry Riehman, Dr. Grassel, Hunt Mayo and many others.

\*\*\*\*\*

THE KENTUCKY POST

28 September 1898

Page 4, col. 3

\*\*\*\*\*

MAY LEAVE.

-----

Covington Glass Company  
Claim That The City

-----

Has not Kept Faith With It as  
Regards Free Water.

The Covington Glass Company, a new concern recently organized in Covington for the manufacture of bottles and other glass goods, is threatening to pull up and leave.

Samuel Brown, one of the owners of the plant, which is located in the old Hemingray Glassworks, called on Mayor Rhinock Wednesday and stated the company's grievance. Brown claims that the city promised to exempt the company from taxation for five years and furnish a supply of water free. When he called on the Water-works people Brown claims he was told that the company would have to pay for the water.

Brown told the Mayor that the company would certainly leave if the agreement was not kept.

Mayor Rhinock advised Brown to lay the matter before the Water-works Commissioners. The concern employs about 50 hands.

\*\*\*\*\*



CD 263  
\$166.40 per 1000



THE KENTUCKY POST

29 November 1898

Page 3, col. 4

\*\*\*\*\*

SALE ORDERED

-----

of glass plant for bene-  
fit of creditors.

-----

IMPORTANT DECISION MADE

-----

By Judge Tarvin in Circuit-Court  
Cases

Judge Tarvin rendered decisions Tuesday in the following Circuit-Court cases:

In the case of R. B. Shepherd and others against the Covington Glass Company, the receiver, George McKiefer, was authorized to dispose of the company's property, either by public or private sale, the property to be appraised by disinterested parties.

\*\*\*\*\*

THE MORNING STAR

Muncie, IN

6 May 1901

Page 5, col. 3,4

\* \* \* \* \*

HEMINGGRAYS TO STAY HERE

-----

They Will Manufacture Producer Gas

-----

Ball Brothers and Others Will Do the Same.

-----

Two of Muncie's largest manufacturing concerns are preparing to equip their plants with furnaces for the manufacture of producer gas. The Hemingray Glass Company has contracted for the construction of a tank and gas producer, which will exceed in capacity the natural gas tank now in use. It will be built just east of the present continuous tank, and will be kept in reserve until such a time as the supply of natural gas in this plant shall have failed.

J. O. Janson, a representative of a company which builds gas producer tanks, is in the city preparing to construct the furnace for the Hemingray Glass Company. The method used is one of largest triumphs of the producer gas trade, and is said to be both economical and effective. Some time ago there was talk of the removal of the Hemingray plant from Muncie. This action would seem to dispel all doubts as to their permanency.

Ball Brothers were interviewed by a Star representative Tuesday. They said they were preparing to introduce a system of producer gas tanks in their factory for use when the supply of natural gas should become inadequate. They were not prepared to say how many furnaces would be equipped. The question being left to future experiments.

Mr. Janson, who will construct the Hemingray tank, is now figuring with Ball Brothers, and it is not improbable that the same system will be introduced in their factory. Mr. Ball could not say at the time what kind of coal would be used in the manufacture of the gas, but he thinks Indiana coal would have the preference. This, too is a matter which will be decided upon by actual tests.

It is certain that the two factories named will continue in operation irrespective of the natural gas supply. It means much for the city, and it is learned that the same system is being considered in at least another glass factory and an iron mill.

\* \* \* \* \*



THE MORNING STAR

Muncie, IN

6 May 1901

Page 8, col. 3

\* \* \* \* \*

Thomas J. Conway, a glass worker at the Hemingray factory, has sent his wife to Oregon. She has been in poor health, and it is hoped that the climate in that State will benefit her.

\* \* \* \* \*

THE MORNING STAR

Muncie, IN

7 May 1901

Page 4, col. 4

\* \* \* \* \*

GLASS PLANT IS NOW IDLE

-----

Boys at Hemingray's Struck  
For More Money

-----

CITE CASE AT BALL BROS.

-----

The boys employed at Hemingray's Glass Works are out on a strike for an increase in wages of 20 cents per day. The trouble occurred at noon Monday. The factory, employing several hundred persons, is now idle.

The inception of the trouble dates to a few days ago, when the lehr boys and off-bearers in Ball Brothers' plant were granted an increase of 20 cents a day. A committee from the Hemingray boys called on the company and asked for a like advance, but they were told that their request would not be complied with. They were offered 10 cents a day more, but this was not satisfactory and the strike was inaugurated at noon Monday.

The scale of wages in force among the sticking-up and carrying-in boys in the Hemingray factory has been 70 and 80 cents per day. The demands, if complied with, would mean an increase

to 90 cents and \$1 per day. In all 125 boys are affected by the strike, and the increase asked would mean to the company about \$25 per day.

The company Monday night took steps to get officers to look after the boys this morning. Seventeen boys have signified their willingness to return to work on the day shift and it is the intention of the company to protect them.

MR. HEMINGRAY'S STATEMENT.

Ralph Hemingray, president of the company, stated to a Star reporter Monday evening that the labor question among the boys is fast assuming a serious condition. He said that the boys came to him at 10 o'clock and asked that they be granted an increase in wages of 10 cents per day, as the boys at the Ball Brothers factory had received an increase of that amount. He told them to return to work and he would investigate, and if their statement was found to be true the wages would be regulated to meet this. They returned to work and he telephoned Ball Brothers and ascertained that an increase of only 10 cents had been granted. He posted notices in the factory that the wages had been increased to the amount asked, but, when the noon hour arrived, the boys made a new demand for 20 cents increase, he said. This was refused. In Covington, Ky., according to Mr. Hemingray, the boys are glad to receive \$3 per week and even less. With the advance granted the men some time ago, it means additional wages of \$8,000 a year. The plant employs about 375 hands.

\* \* \* \* \*

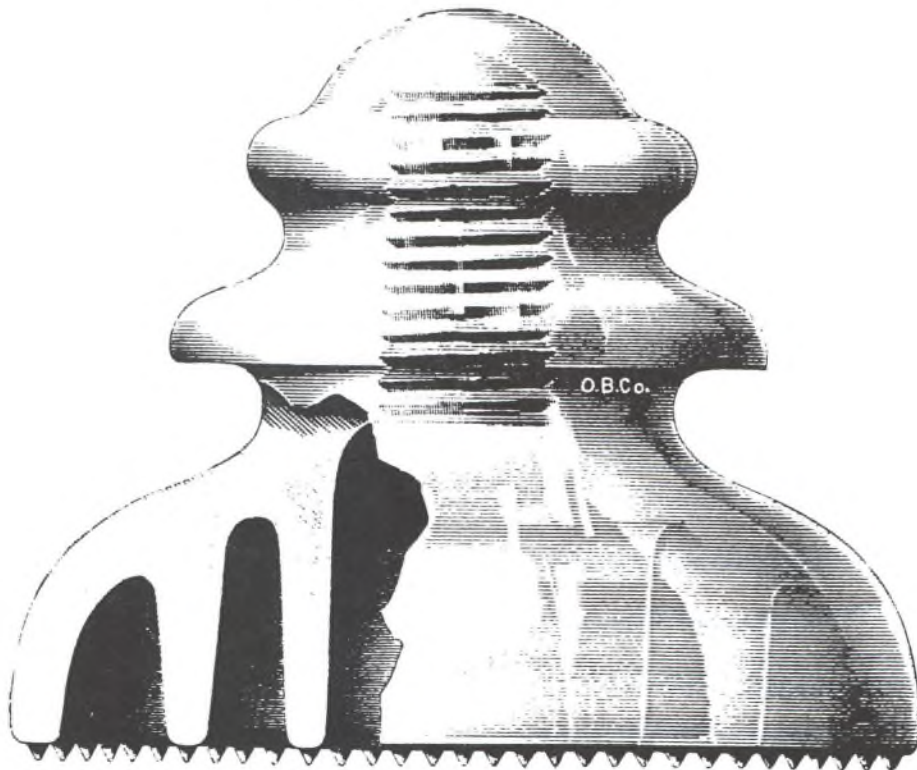

CD 282  
\$264.00 per 1000



THE MORNING STAR

Muncie, IN

13 April 1907

Page 6, col. 6

\* \* \* \* \*

INVENTION A SUCCESS

-----

GLASS PRESSING MACHINE

-----

Thomas J. Conway, Muncie Man  
Says Trade Will be Revolutionized.

-----

Thomas J. Conway, a glass presser employed at Heminway (sic) factory, and residing at 1007 Kirby Avenue, has been granted a patent on a glass pressing machine, which he claims will revolutionize the industry over the country. Mr. Conway has just come into receipt of the papers granting him the right of patent.

For two years Mr. Conway, assisted by Deputy State Factory Inspector Harve Richards, have been actively engaged in working on the invention, which according to the inventors, is a success and will prove so when it is offered to the market. The invention, which is the first of its kind, will routineize the industry in that it does away entirely with the boys and pressers to operate the machine. If the invention is a success a fortune lies in the path of the inventor. The only drawback to the invention having been completed by someone years ago was the arrangement of the machinery so as to operate the peculiarly shaped screws on the molds. Unless the screws are operated correctly they shatter the threads on the insulators and other glassware. Mr. Conway claims that he has overcome that obstacle. The three boys and presser to each machine are entirely done away with. Mr. Conway has received a number of flattering offers for his invention, but has not decided to accept any.

\* \* \* \* \*

THE MUNCIE SUNDAY STAR

6 December 1925

Section 3, page 1, col. 1

\* \* \* \* \*

GLASS COMPANY  
HAS FINE RECORD

-----  
Hemingray Plant Has Oper-  
ated Continuously for  
Over 75 years.

-----  
By E. M. Branigin

For over three-quarters of a century the Hemingray Glass Company has been in continuous operation, having been founded at Cincinnati, Ohio in 1848 by Robert and Samuel Hemingray. To have weathered all economic storms during that period is an indication of the strength of organization that has made the plant the foremost of all the country's manufacturers of glass insulators.

The plant was moved to Covington, Ky., in 1861, and twice it was destroyed by the flood waters of the Ohio. Unsatisfactory working conditions at this place and the attractiveness of Muncie as a location for a factory on account of the oil and gas boom were among the reasons for the company moving to this city in 1888. Two years later operations at the Covington factory were discontinued and the entire plant moved to Muncie.

New Field Opens.

In the beginning and for ten years following the Hemingray Glass Company manufactured glass lamps, jars, demijohns, and flasks. However in 1861 following the invention of the telephone and the extension of lines of communication a new field was open to the glass manufacturer in the form of insulators. Telegraph lines and electric power lines followed closely and the development of the new industry can be traced with the extension of these different systems.

Development of the manufacture of insulators gained such headway that in 1900 the company gave its entire time to this product and for many years held a position as one of the leading insulator manufacturers in the country, and is the oldest continually operating company since the founding of the industry.

Large Export Business.

A large amount of the output of the company is exported. Shipments have been made to South Africa, South America, Spain, the Philippines, and Australia. The bulk of the export business is done with countries that are being exploited by American capital. Where English companies are in control of the development it is natural that their own products should be used.



For a long time it was believed that the inner threads of the insulator had to be made by hand. The insulator glass press that now does the work is just as efficient and speeds up production to a large extent. The Hemingray Company developed this new method.

#### Return to Old Line.

The introduction of this new process made it possible for the company to return to its original line of production and last year the manufacture of beverage and water bottles was resumed in one factory. The demand for glassware of this kind is unlimited and with the big jump in production it became necessary to seek larger quarters. About March of this year a third factory is to begin operation in order to meet the demand.

There are a number of smaller glass factories throughout the country that are larger but none of them are better equipped. The engineers of the company have constantly experimented for the purpose of making their methods more efficient and at the present time it ranks among the best of its kind.

#### Have Made Rapid Strides.

Although due to the fact that there is only a limited demand for insulators inasmuch as it is determined by the extension of telephone, telegraph, and electric power lines throughout the world, this branch of the business still is considered the main product. The possibilities of the beverage and water bottle business however seem to be greater. This product is only sold in the middle west as compared to the export business of the insulators.

The entire organization of the company is one that works in perfect accord, is directed by an efficient head, with the result that in the last five years marvelous changes have been made and are indicative of even more rapid strides forward in the industrial world.

\* \* \* \* \*

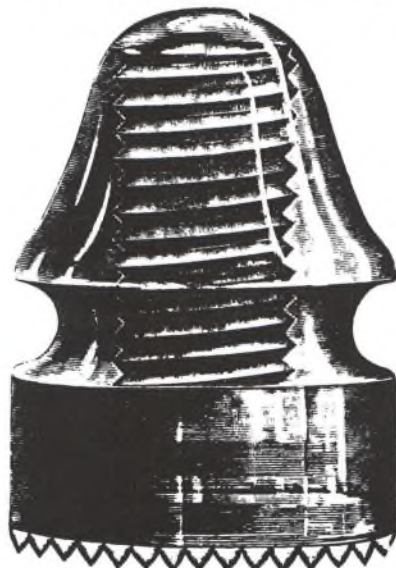

CD 134  
\$40.80 per 1000

THE MUNCIE MORNING STAR

16 March 1933

Page 1, col. 8

\*\*\*\*\*

Glass Company  
Ready to Make  
Beer Bottles

-----O-----

Fires were lighted under the large tanks at the Hemingray Glass Company yesterday in preparation for a full-time schedule within the next ten days or two weeks, according to announcement made last night by officials of that company.

In view of the beer bill passage in the House of Representatives, and the indication that the Senate would also pass the bill, numerous breweries have placed orders with the local company and it was announced yesterday the contracts already received would give employment for an indefinite period.

Orders for 500 Cars of Bottles

News of the contracts was also accompanied by announcement that the employment staff of the company would be substantially increased. The number employed at the present time is a low minimum, but with the new contracts, the employment staff will be increased to between 250 and 300 persons.

As has been the custom among nearly all the factories, former employes will be recalled first. When the operative schedule is started these men will be employed on a twenty-four hour shift, seven days a week, thus assuring constant employment for many months.

Contracts already received by the Hemingray Glass Company represent nearly 500 cars of bottles it was said. Those placing the orders are ready for instant operation, it was said, and are largely within a radius of 250 miles of Muncie.

\*\*\*\*\*



THE MUNCIE MORNING STAR

4 May 1933

Page 1, col. 2

\*\*\*\*\*

OWENS-ILLINOIS  
COMPANY BUYS  
LOCAL INDUSTRY

-----

Hemingray Glass Factory  
Becomes Unit of Corpora-  
tion -- New Product.

-----

Purchase of the Hemingray Glass Company by the Owens-Illinois Company, announcement of which was made yesterday by William E. Levis of Toledo, President of the Owens-Illinois, brings into the hands of the Owens-Illinois people practically the last of the unlimited licenses held by any independent glass company.

It has been generally understood in the trade that the Hemingray Company was the only independent company still operating under an unlimited license from Owens-Illinois and that the latter company has been desirous of obtaining this license for some time.

New Products Developed.

Negotiations for purchase of the local plant started more than a year ago but were not completed until just a few days ago when final sanction was made to the sale by the stockholders of the Hemingray Company. The Owens-Illinois Company operates some twenty plants and the local factory will become a unit of this big corporation.

Although announcement was made that another tank will be started in the Hemingray plant for the manufacture of beer bottles, the official announcement of Mr. Levis would indicate that eventually the local plant will engage in the manufacture of another class of glassware.

The industrial materials division of the Owens-Illinois Company has recently developed a number of new glass products and these may enter into the future operation of the local plant. The Owens-Illinois Company is now operating at full capacity to meet its bottle demand and just recently let a sub-contract to the Ball Brothers Company for bottles. The Hemingray tanks can now be operated at full capacity to aid Owens-Illinois in meeting its bottle demand. With a slackening of the bottle demand, it is supposition that the Hemingray plant will then turn its attention to insulators and glassware other than bottles.

Some of the officials of the Owens-Illinois Company are expected in Muncie today to make a survey of the local property, and some announcement may be as to changes, if any, in the operation of the local plant.

### Announcement Is Surprise.

With an unlimited license for the manufacture of glassware, and the recent advent of legal beer and its subsequent influx in the beverage bottle industry, the outlook for the future at the Hemingray company was unusually bright and news of the purchase by the Owens-Illinois was somewhat a surprise here, despite the fact that the negotiations began some time ago.

According to the announcement received yesterday from President Levis relative to the local factory purchase, it was said the glass insulator business carried on by the Muncie factory will become a part of the industrial materials division of the Owens-Illinois Company, which has recently developed a number of new glass products, among them glass wool for building insulation and for air filtering installations. A glass building now under construction at the Century of Progress Exposition at Chicago will introduce glass block as a structural and decorative material to the public.

For the past seventy-five years the Hemingray Glass Company has manufactured high grade glass insulators, and during that time has built a tremendous business and precedent in this line of the glass business. Besides selling insulators in the United States, Canada, and Mexico, they sent large shipments to twenty-seven other countries, and the caliber of insulators was perhaps recognized as the best in the world. Due to this fact it was thought likely that the local plant would be maintained primarily for the continued manufacture of these products.

The Hemingray Glass Company was established in 1848 in Cincinnati. In 1861 the plant was moved to Covington, Ky., where it remained until 1887. During the gas boom of that year the plant was shifted to Muncie, where the gas supply was seemingly unlimited and exceedingly cheap.

### Destroyed By Fire.

During the summer of 1892, just as the factory had become definitely established here, the plant was destroyed by fire. But those in charge of the operation and management rebuilt it and after rebuilding it Ralph Hemingray assumed executive charge. Previous to this Robert Hemingray, father of Mrs. P. H. McAbee, of Muncie, was president.

Weathering the smallpox and other epidemics and also the depression of 1893-94, business at the Hemingray plant began to pick up in 1895. The manufacture of glass insulators was begun in 1858, but it was not until 1900 that the company devoted its attention to the glass insulators. Then, due to the large market resulting from the growth of independent telephone companies and rapid expansion of the telephone and electric light industry, the manufacture of the insulators was stressed more than ever.

At the death of Ralph Hemingray in 1920, Philip W. McAbee became president and general manager, with A. C. Shinkle, vice-president; W. P. Zimmerman, secretary-treasurer; C. H. Smith, assistant treasurer and purchaser, and F. J. Leah, auditor.



Since the establishment of the factory until the present time, employment given by it has been a tremendous factor in the welfare and life of the city of Muncie. The average employment of the company during these years was estimated at 250, although the peak years of 1928-9 resulted in an employment staff of approximately 750. At the present time there are about 275 employed, with contracts insuring steady employment for these men for an indefinite period, plus the probability of additional contacts which would likely increase the employment staff.

\*\*\*\*\*

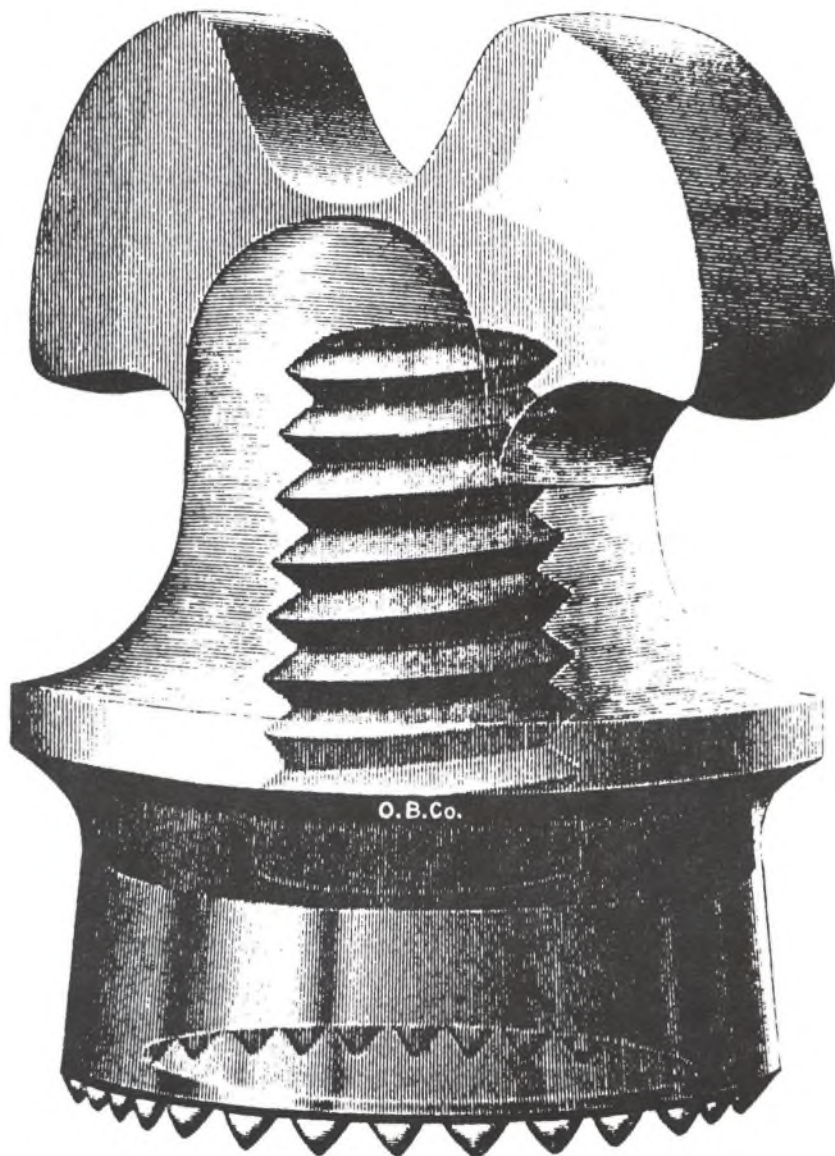

CD 257  
\$82.00 per 1000

THE MUNCIE MORNING STAR

3 February 1934

Page 1, col. 6

\* \* \* \* \*

Made Manager  
At Hemingrays

-----O-----

(PICTURE)

Promotion of W. Paul Zimmerman to sales and plant manager of the Hemingray division of the Owens-Illinois Glass Company in Toledo.

Mr. Zimmerman has been with the local company for more than thirteen years, having come to Muncie as secretary-treasurer of the Hemingray Glass Company in 1920 after foreign service during the World War. He has been assistant to the manager during the past several years, when Philip W. McAbee was head of the local plant. He is a graduate of Miami University at Oxford, O.

To Continue Present Lines.

The departure of Mr. McAbee for an extended trip to California brought out the organization changes in the local division of the Owens-Illinois company.

It is understood that Mr. McAbee retires from active connection with the Hemingray division, but that he expects to continue with the parent company through affiliation with the general headquarters of the organization at Toledo, upon his return from the coast.

Mr. Zimmerman has already assumed his new duties as plant and sales manager. He said yesterday that it is the intention of the general management to continue the manufacture and development of glass insulators and allied products here at the Muncie plant. Every facility of the Owens-Illinois Glass Company will be extended the Hemingray division in the further exploitation of the field in which the name "Hemingray" has been so long preeminently recognized.

\* \* \* \* \*

TRADE MARK  
STANDARD HEMINGRAY INSULATORS  
REGISTERED.



# THE AD ROOM



CD 154





## A FEW NOTES ABOUT THE AD ROOM

This section contains Hemingray and Owens-Illinois ads found in various magazines and journals, along with pages from several electrical supply company (or trade) catalogs. Most of these items were furnished by Elton Gish. A few came from Bob Stahr, Mr. N. R. Woodward, Glenn Drummond, and Mike Sovereign. I thank these friends so much for the time it took to look up all of these things, make copies, and write the names and dates of the publications on each one. These ads and catalog pages add the artistic touch that my book needed. (The ads are not always shown at their original size.)

Bob Stahr notes that in the Western Electric trade catalog from 1915, on their page 1063 (my page 345), they illustrate an insulator that has not been located yet. The Hemingray 41 shown there also appeared in a 1916 catalog; we suspect that this was produced, but no examples have been found to date.



### "Provo" Insulator.

The Hemingray Glass company of Covington, Ky., is placing on the market the "Provo" type insulator for high-potential work, which has given such excellent results on the 40,000-volt plant of



"PROVO" INSULATOR.

the Telluride Power Transmission company in Utah. The insulator was perfected nearly a year and a half ago, and is the outcome of several years of experiment, with existing types and many new forms.

It is all glass, which is the cheapest insulating material and, according to the makers, is the only one that is absolutely reliable when exposed to the weather and the action of high-potential currents.

It is 5 $\frac{3}{4}$  inches high and seven inches in diameter and has five petticoats. Two of these petticoats are near the line wire and serve to break the continuity of the exposed surface between the wire and the pin of the cross-arm, which tends to prevent jumping of the current between these points. Another advantage of these petticoats near the line wire is that they protect surfaces of small area and high resistance, which check surface breakage at its source. It is noticed in actual practice that these surfaces remain free from moisture and snow. The other petticoats on the bottom extend the surface distance from the line wire to the pin to 16 inches.

The line wire is tied around the insulator in the topmost groove, which holds it well above the cross-arm. This method of tying has been adopted, as it is considered the best for use in a country where the strain on an insulator may be either up or down or sidewise.

The thickness of glass is well proportioned and the insulator is extra strong in resisting mechanical breakage or electrical punctures. Tests have been made between the points for the wire and the pin with voltages as high as 125,000, without puncturing the material. The thread is of standard size and 2 $\frac{1}{2}$  inches long. The strain of the wire comes squarely on the pin. The glass is almost colorless and the insulator is not conspicuous on a pole line.

The name of Hemingray is a sufficient guarantee for good work in the glass-insulator line. The company has increased facilities for manufacturing this insulator and is prepared to fill orders on short notice.

Article/company ad.

Western Electrician, Vol. XXII No. 26

24 Dec 1898

(Courtesy of Glenn Drummond)



# PROVO TRIPLE PETTICOAT INSULATORS GUARANTEED TO DO THE WORK

ESTABLISHED

1848

INCORPORATED

1870

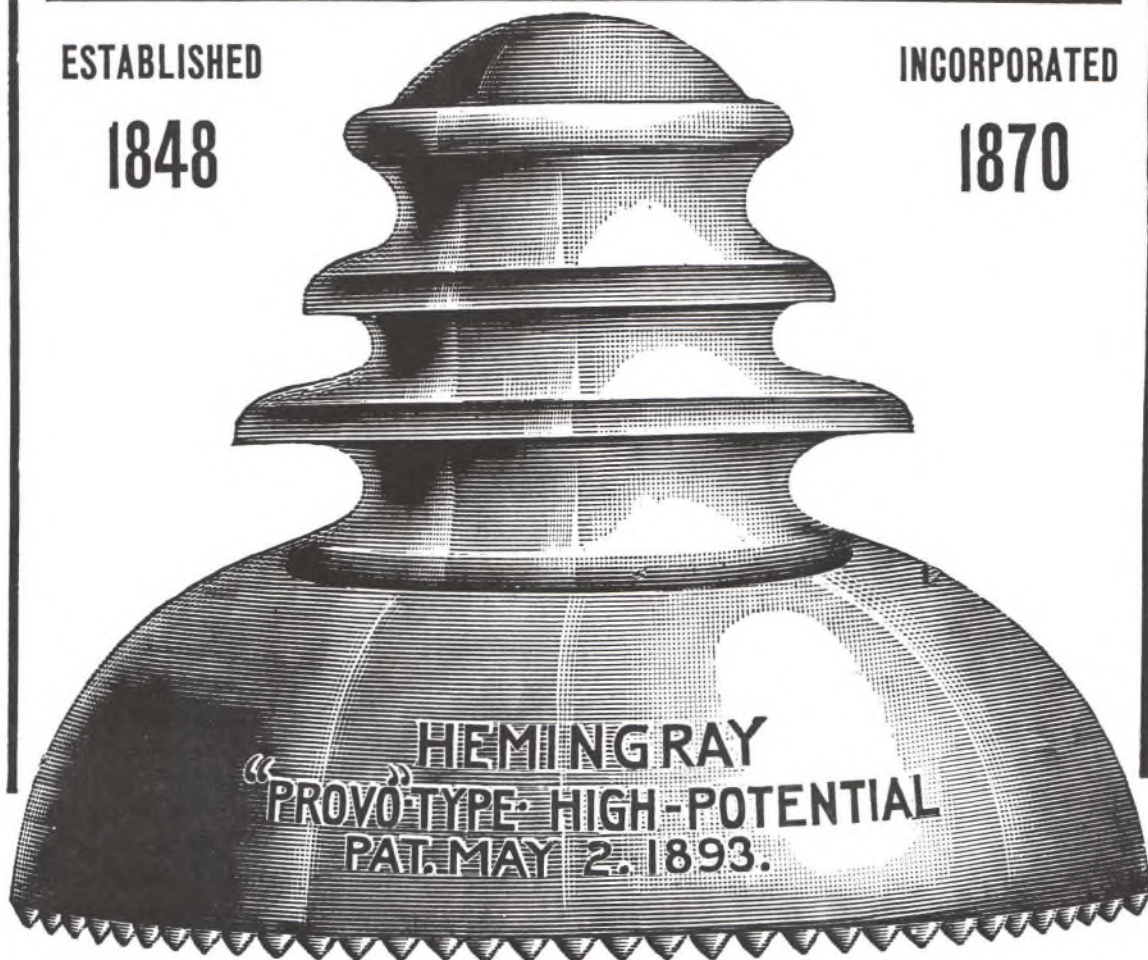

PROVO TYPE High Potential, Guarantee 40,000 Volts

**THE HEMINGRAY GLASS CO.**

OFFICE, COVINGTON, KY., U. S. A.

(1)

FACTORIES, MUNCIE, IND.

Company ad.  
The Electrical World and Engineer  
29 Jun 1901  
(Courtesy of Elton Gish)

**THE "PROVO" TRIPLE PETTICOAT  
GUARANTEED INSULATORS**

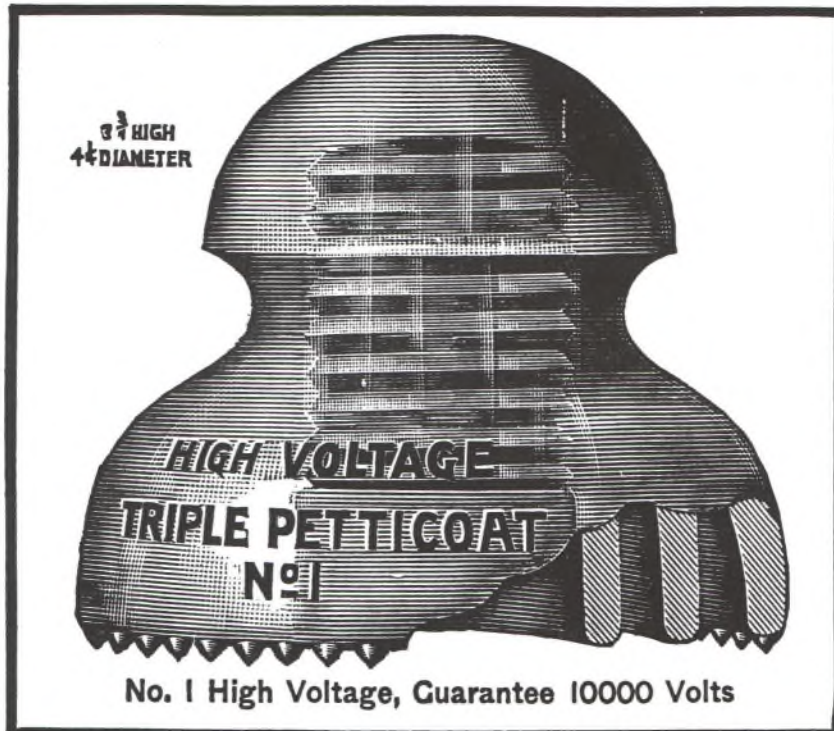

**MANUFACTURED BY**  
**THE HEMINGRAY GLASS CO.**  
ESTABLISHED 1848      INCORPORATED 1870  
Office, Covington, Ky.      (2)      Factories, Muncie, Ind.

Company ad.  
The Electrical World and Engineer  
28 Dec 1901  
(Courtesy of Elton Gish)



# Hemingray Insulators

For Heavy Voltages

## Standard of the World



**The Chas. F. Sloane Co.**

Exclusive Pacific Coast Sales Agents

Mills Building

San Francisco, Cal.

The Chas. F. Sloane Co. ad.  
The Journal of Electricity, Power and Gas, Vol. XIII  
Jan-Dec 1903

(Courtesy of Fred Padgett)

### "Provo" Insulator.

In the insulator shown in the accompanying illustration the pin is surrounded by an insulating sleeve, which affords considerable additional insulation to the total, inasmuch as it keeps the pin dry and clean. This sleeve, however, is adapted only



INSULATOR.

for a treated wooden pin, since with a pin of metal or other conducting material a high-tension current would bridge the space between the sleeve and pin.

Insulators of this construction have been in service on the Missouri River Power Company's transmission system a sufficient length of time to prove them to be satisfactory and reliable, and they are recommended by the manufacturer, the Hemingray Glass Co., Covington, Ky., for pressures ranging from 55,000 to 60,000 volts.

These insulators are  $6\frac{1}{2}$  in. high and  $8\frac{1}{2}$  in. diameter, and weigh 8 lb. 4 oz. each.

Article/company ad.  
The Electrical World & Engineer  
7 Feb 1903  
(Courtesy of Elton Gish)



# “HEMINGRAY” STANDARD Screw Glass Insulators



Two-Piece  
Transposition.



All with the  
“Patent Drip  
Petticoats.”



## The Hemingray Glass Co.

Office, Covington, Ky.

Factory, Muncie, Ind.

ESTABLISHED 1848

Company ad.  
Electrical Review  
23 May 1903  
(Courtesy of Elton Gish)

# HEMINGRAY GLASS

BEST FOR EVERY PURPOSE

TELEPHONE ⚡ RAILWAY  
TELEGRAPH ⚡ POWER

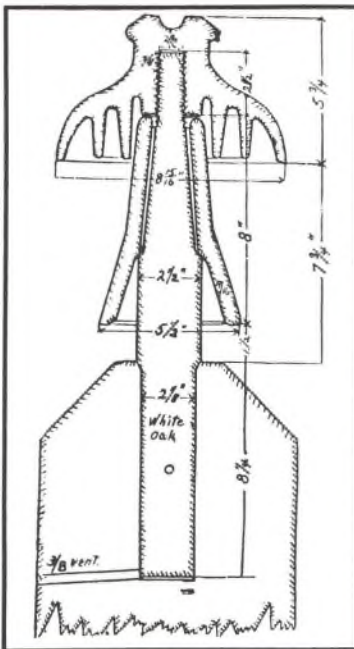

### THE GERRY 55,000-VOLT INSULATOR

Information is frequently sought concerning the type of insulator used on the high voltage transmission between Canyon Ferry and Butte, and especially is it desired to know the dimensions of the insulator and the success which has attended its use. As is generally known, the insulator is made of glass, produced by the Hemingray Glass Company, of Covington, Ky., and its outlines and dimensions are as given in the accompanying sectional sketch, which is from the original drawings of Mr. M. H. Gerry, Jr., chief engineer and manager of the Missouri River Power Company, and who designed the insulator.

In view of the completeness of the drawing and the appearance thereon of all dimensional data, a detailed description of this remarkable insulator is unnecessary, beyond stating that it, together with its tapered glass sleeve, is all glass, non-cemented. It is stated that these insulators have proven to be absolutely reliable.

One further notation: The ratio in which the transformers are wound is 552 1/2 to 50,000. The generator voltage was stated to be 630 volts, which would give a line potential of approximately 57,000 volts. The weather was clear, cold, dry and crisp.

If you want the best let US know

# Hemingray Glass Co.

Factories: Muncie, Ind.

Office: Covington, Ky.

ESTABLISHED 1848

INCORPORATED 1870

Company ad.  
Electrical Review  
30 May 1903  
(Courtesy of Elton Gish)



# THE "HEMINGRAY" STANDARD SCREW GLASS INSULATORS



7 IN. MUNCIE TYPE  
Guarantee 40,000 Volts

STREET RAILWAY INSULATORS

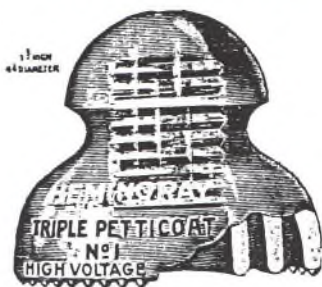

No. 1 HIGH VOLTAGE  
Guarantee 50,000 Volts



DEEP GROOVE DOUBLE PETTICOAT

POWER INSULATORS FROM  
10,000 to 60,000 VOLTS



No. 0 PROVO TYPE  
Guarantee 50,000 Volts

ESTABLISHED 1848.  
**HEMINGRAY GLASS CO.**

OFFICE: COVINGTON, KY.

Company ad.  
The Electrical Age  
Feb 1904

(Courtesy of Bob Stahr and Elton Gish)



**STANDARD**  
**"HEMINGRAY"**  
**STANDARD**

WE MANUFACTURE

**STANDARD  
 SCREW GLASS  
 INSULATORS**

FOR ALL PURPOSES



7 IN. MUNCIE TYPE  
 Guarantee 40,000 Volts



DEEP GROOVE DOUBLE PETTICOAT

**STREET RAILWAY INSULATORS**



No. 0 PROVO TYPE  
 Guarantee 50,000 Volts

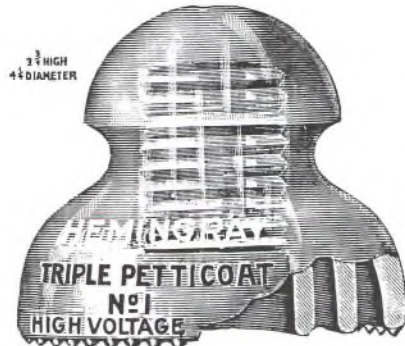

3 1/2" HIGH  
 4 1/4" DIAMETER

No. 1 HIGH VOLTAGE  
 Guarantee 10,000 Volts

POWER INSULATORS FROM  
 10,000 to 60,000 VOLTS

**ESTABLISHED 1848**  
**THE**  
**HEMINGRAY GLASS CO.**  
 OFFICE:  
**COVINGTON, KY.**

Factories,  
 Muncie, Ind.

Company ad.  
The Electrical Age  
 Mar 1904

(Courtesy of Elton Gish and Bob Stahr)



TRADE MARK  
**HEMINGRAY**  
 REGISTERED.



No. 19, Deep Groove Double Petticoat.      No. 71, High Voltage Triple Petticoat.      No. 2 Cable, Double Petticoat.

For years the name "Hemingray" has been synonymous, not only with "glass insulators," but with "good glass insulators." The Hemingray insulators have been and are *good insulators*, because they have been and are of good design and material subjected to proper processes of manufacturing, including especially perfect annealing. In a glass insulator, "good design" means more than proper lines electrically,—it means a design which so distributes the material that good annealing is possible. Given such a design and a proper proportioning of materials (including *not too much cullet*), it is possible to obtain, and the Hemingray Glass Company does produce a completed insulator, every part of which is perfectly annealed.

Thorough annealing is of supreme importance in a glass insulator, and faults which have been found against glass as a material for line insulators have been due to the past practice of some other manufacturers who not only have used improper annealing methods, or materials which was practically impossible of being properly annealed, but also have accepted for manufacture certain designs of insulators which so distributed the material as to make proper annealing practically impossible, no matter what materials or methods were used. The HEMINGRAY GLASS COMPANY has followed as one of its first principles the practice of not accepting for manufacture any design which their sixty-five years of experience would indicate could not be properly and perfectly annealed. This is the prime reason for the uniform success of the Hemingray insulator; the reason for its superior mechanical quality of strength and capabilities to withstand the shocks of sudden blows or rapid and extreme temperature changes; the reason for its remarkable electrical qualities as a high voltage insulator.

**Insulators for Telephone, Telegraph, Light and Power**

**HEMINGRAY GLASS CO.**

Established 1848

Incorporated 1870

**COVINGTON, KY.**

**Factories - - - MUNCIE, INDIANA**

Company ad.  
Telephony  
 Dec 1904

(Courtesy of Glenn Drummond)

SEE THE  
**Teats on the Petticoat**

They take all the moisture from the inner and outer surface of the insulator and keep the pin dry.



**Hemingray Glass Company**

ESTABLISHED 1848 }  
INCORPORATED 1870 } COVINGTON, KY

**Factories, - MUNCIE, INDIANA**

Company ad.  
Electrical Review  
13 May 1905  
(Courtesy of Elton Gish)



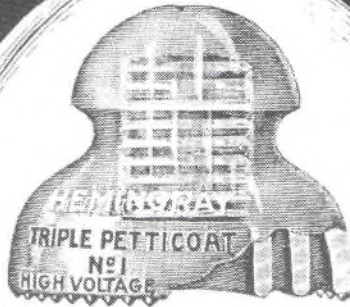

# STANDARD

## Screw Glass Insulators For All Purposes

We've made glass insulators so long and so successfully that you can be absolutely certain that the goods are right.

All with the "PATENT DRIP PETTICOATS"  
**SEE THE TEATS  
ON THE PETTICOAT**

They take all the moisture from the inner and outer surface of the insulator and keep the pin dry.

**Hemingray Glass Co.**  
Covington, Ky.

FACTORIES: MUNCIE, IND.

ESTABLISHED 1848

ELEC. REVIEW

Company ad.  
Electrical Review  
14 Apr 1906  
(Courtesy of Elton Gish)

# Hemingray Insulators

WORLD'S STANDARD

5½" HIGH  
7" DIAMETER

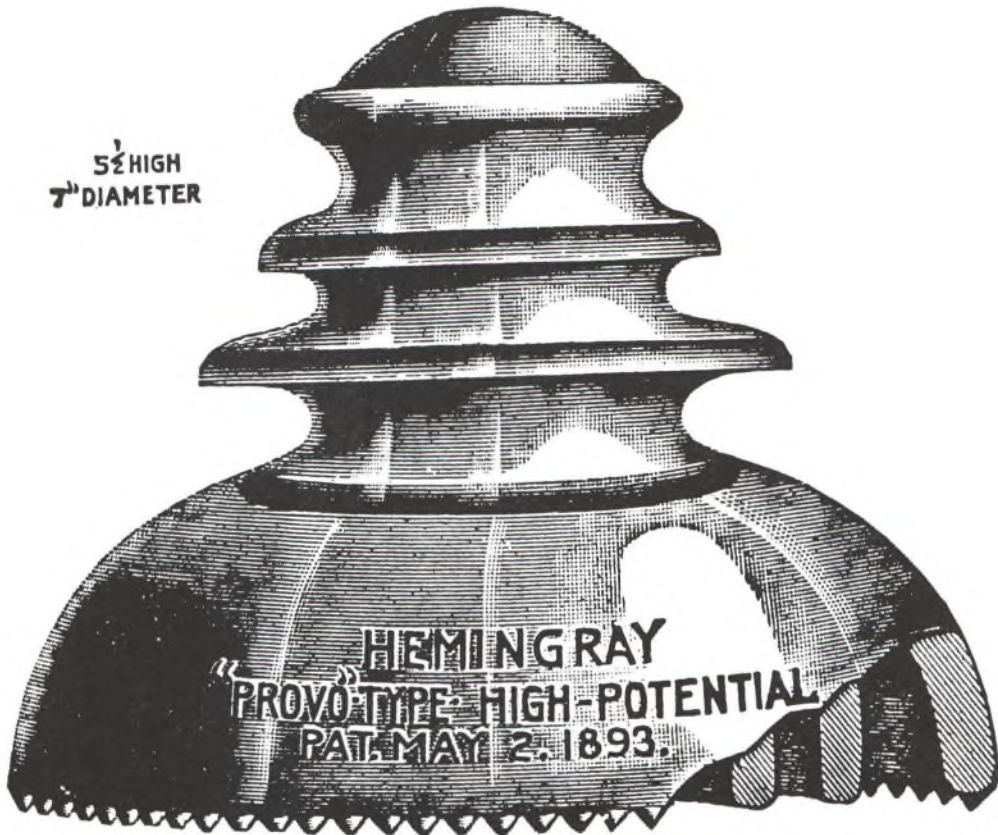

For Voltages up to 75000  
Also Standard Insulators

*For all Purposes, Telephone, Telegraph, Lighting, Power*

*—Complete stock of all Insulators are carried by—*

**Electric Appliance Co.**      **Kilbourne & Clark Co.**  
SAN FRANCISCO                      SEATTLE

**Pacific Electrical Works**  
LOS ANGELES

Company ad.

The Journal of Electricity, Power and Gas  
5 Jan 1907

(Courtesy of Elton Gish)



**HEMINGRAY**  
**PATENT MAY 2<sup>ND</sup> 1893**

**ABSOLUTELY**  
**MOISTURE-PROOF**  
**HEMINGRAY**  
**STANDARD**  
**SCREW GLASS INSULATORS**

TAKE ALL THE MOISTURE FROM THE INNER AND OUTER  
SURFACE OF THE INSULATOR AND KEEP THE PIN DRY.

SEE THE TEATS ON THE PETTICOAT  
**HEMINGRAY GLASS CO.**

Est. 1848. Inc. 1870. COVINGTON, KY.  
(2) Factories, MUNCIE, IND.

Company ad.  
Electrical Review  
29 Jun 1907

(Courtesy of Bob Stahr and Elton Gish)

# SEE THE TEATS ON THE PETTICOAT

They take all the moisture from  
the inner and outer surface of the  
insulator and keep the pin dry.

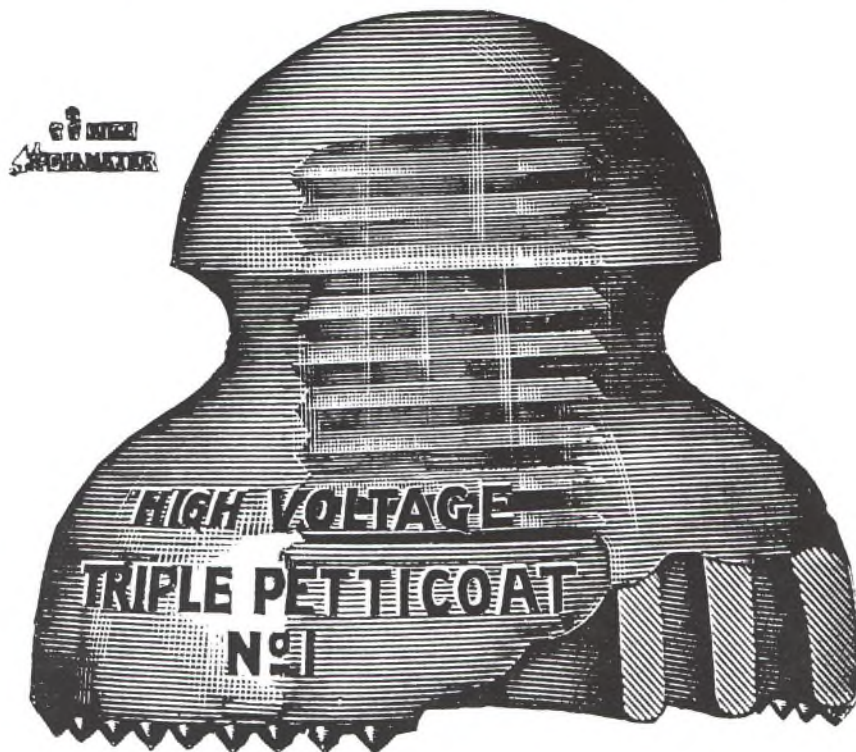

## HEMINGRAY GLASS COMPANY

Established 1848 }  
Incorporated 1870 } COVINGTON, KY.

Factories, . . . MUNCIE, INDIANA.

Company ad.  
The Electrical World  
7 Sep 1907  
(Courtesy of Elton Gish)



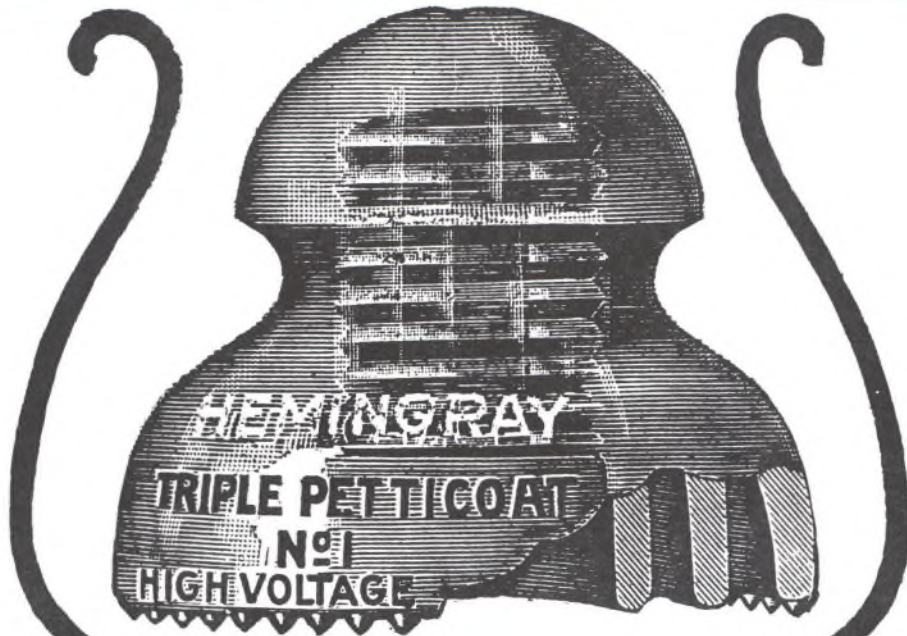

**CONTINUOUS**

and satisfactory service can only be had  
by using the best and most sub-  
stantial insulators.

**HEMINGRAY**

STANDARD SCREW GLASS INSULATORS are used by the most suc-  
cessful telephone, telegraph and power companies in the world.

There's a reason for this,  
Do you want to know why?

SEE THE TEATS ON THE PETTICOAT

**HEMINGRAY GLASS COMPANY**

Established 1848.

Incorporated 1870.

COVINGTON, KY.

Factories, MUNCIE, IND.

(1)

Company ad.  
Electrical Review  
11 Jan 1908  
(Courtesy of Elton Gish)

**HEMINGRAY  
STANDARD**

**SCREW GLASS INSULATORS**  
FOR ALL PURPOSES

**TELEPHONE—TELEGRAPH—RAILWAY—POWER**

SEE THE TEATS ON THE PETTICOAT

**HEMINGRAY GLASS CO.**

EST. 1848    INC. 1870.    COVINGTON, KY.

(3) FACTORIES, MUNCIE, IND.



Company ad.  
Electrical Review  
7 Mar 1908  
(Courtesy of Elton Gish)



# "HEMINGRAY"

STANDARD SCREW GLASS INSULATORS

The Best for All Purposes

ABSOLUTELY  
MOISTURE-PROOF

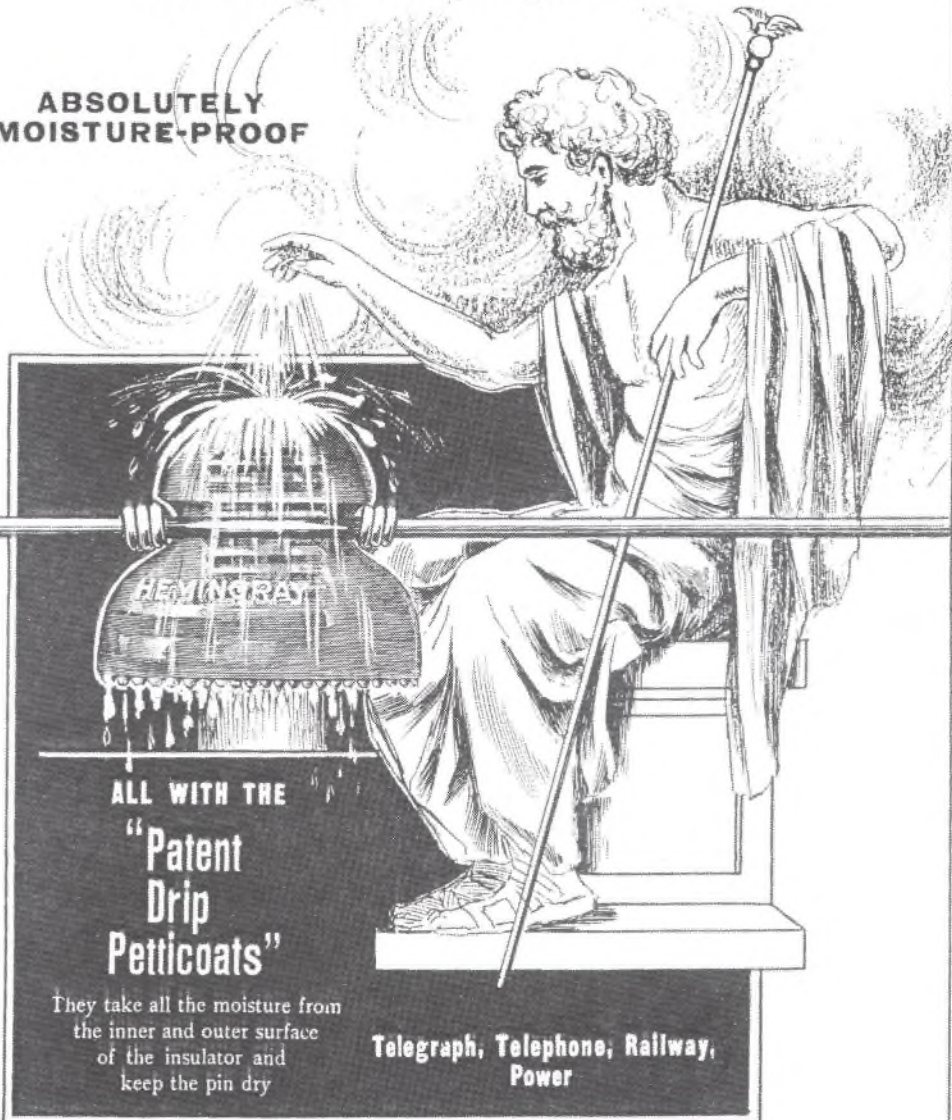

ALL WITH THE  
"Patent  
Drip  
Petticoats"

They take all the moisture from  
the inner and outer surface  
of the insulator and  
keep the pin dry

Telegraph, Telephone, Railway,  
Power

## Hemingray Glass Co.

ESTABLISHED 1848

Factories: Muncie, Ind.

Office: Covington, Ky.

Company ad.  
Electrical Review  
16 May 1908  
(Courtesy of Elton Gish)

# The greatest insulator success

yet achieved by high  
efficiency insulators  
has been that of



## Hemingray Insulators

correctly formed for the service.

### See the Teats on the Petticoat

They attract the water and gather it in  
drops, preventing it  
from creeping to pin  
from insulator.

Full line, all sizes.  
See our Catalog.



## HEMINGRAY GLASS CO.

Covington, Ky.

Muncie, Ind.

4

Company ad.  
The Electrical World  
27 May 1909  
(Courtesy of Elton Gish)



3 7/8 HIGH  
4 1/4 DIAM.

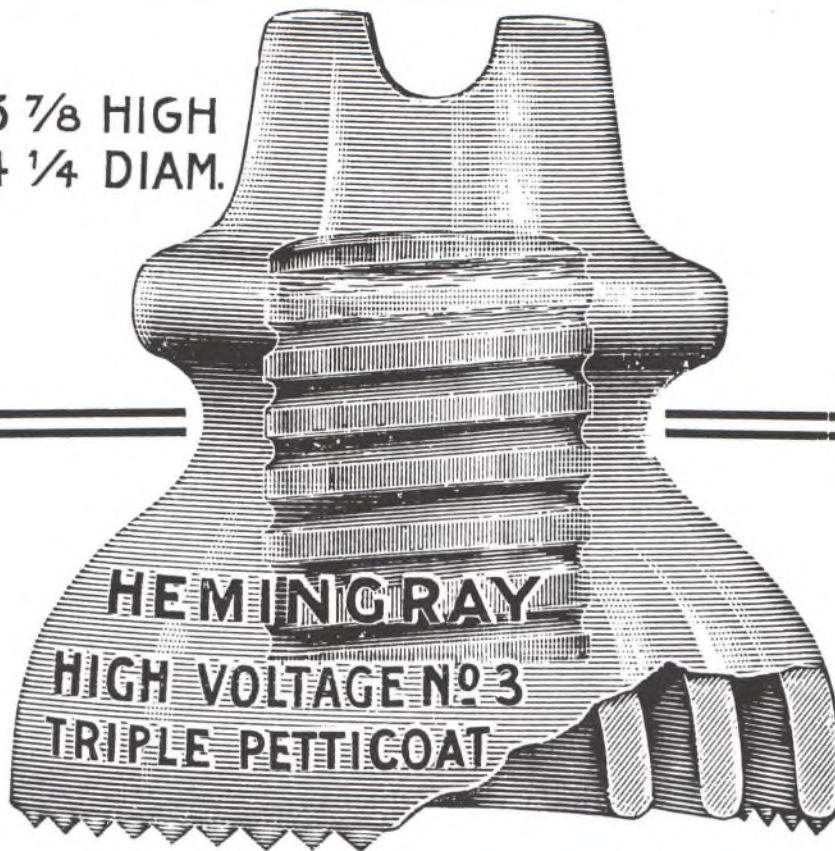

See the teats on the petticoat

# THE WORLD'S STANDARD

Hemingray Insulators have been on the market for many years—they're kept in the van of improvement. Our high voltage types with patent drip petticoats are particularly worthy of notice. All in catalog—get it.

**HEMINGRAY GLASS CO.,**  
Covington, Ky.                      2                      Muncie, Ind.

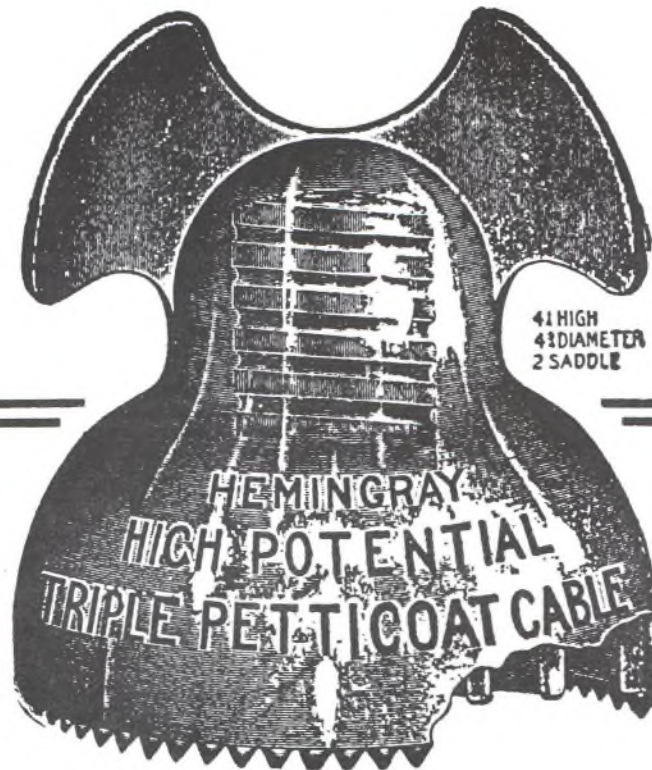

## Transmission Line Success

depends largely upon how the insulators will act in wet weather.

## Hemingray Insulators

with

## teats on the petticoat

prevent moisture from creeping from insulator to pin. Specify Hemingray. Booklet on request.

# HEMINGRAY GLASS CO.

Covington, Ky.

(3)

Muncie, Ind.

Company ad.  
The Electrical World  
22 Jun 1911  
(Courtesy of Elton Gish)





## GET HEMINGRAY GLASS INSULATORS

For Best Transmission

The teats on the petticoat, an exclusive feature of Hemingray Insulators, prevent water running to pins and causing grounds.

Hemingray Insulators are all insulation and are unusually free from breakage.

*Write for Prices*

**Hemingray Glass Co.**  
Covington, Ky.

Factories: Muncie, Ind.

Company ad.  
Telephony  
28 Dec 1912  
(Courtesy of Elton Gish)



HEMINGRAY

*Specify*

**HEMINGRAY**

*Glass*

*Insulators*

*The Standard*

HEMINGRAY  
GLASS COMPANY  
COVINGTON, KENTUCKY.

HEMINGRAY

The advertisement is a black and white illustration. It features a large, stylized cloud in the center containing the text 'Specify HEMINGRAY Glass Insulators The Standard'. The background shows a power line tower with several cross-arms, each holding three glass insulators. The insulators are depicted with vertical lines to show their shape and have 'HEMINGRAY' written on them. The entire scene is set against a background of vertical hatching lines.

Company ad.  
Telephony  
14 Jun 1913  
(Courtesy of Elton Gish)



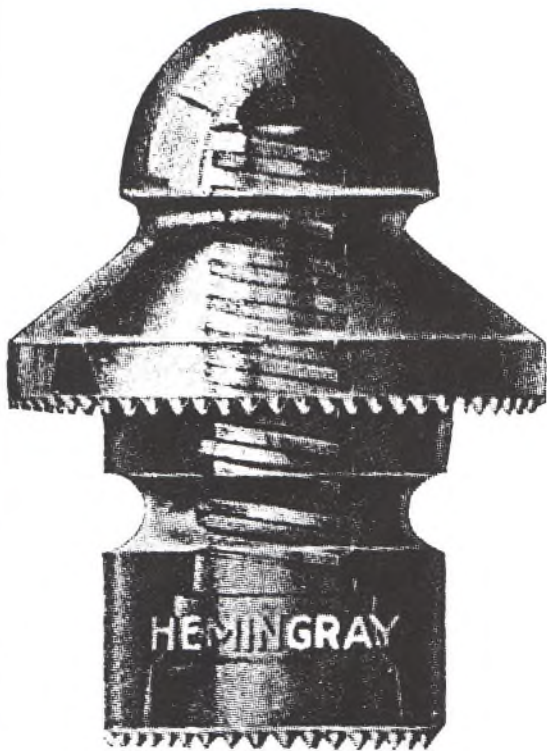

**“The Best on the Line”**

# **HEMINGRAY INSULATORS**

*All styles and design are illustrated  
in our new catalog*

**HEMINGRAY GLASS CO. COVINGTON,  
KENTUCKY**

Company ad.  
Telephony  
4 Jul 1914  
(Courtesy of Elton Gish)

## Put Your Faith in Hemingray Insulators

Experience has shown them the most successful high efficiency insulators on the market.

### The Teats on the Petticoat

gather the moisture in drops and prevent it from creeping to the pin. See the catalog.

## Hemingray Glass Co.

Covington, Ky.

(6)

Muncie, Ind.



Company ad.

The Electrical World

30 Dec 1911

(Courtesy of Elton Gish)

Proper and thorough annealing gives them remarkable insulating qualities

## Hemingray Insulators



No. 20—Line Voltage 5000

are good insulators. The service you get from a glass insulator depends upon so distributing the material that good annealing is possible. We have never accepted for manufacture any design which could not be properly and perfectly annealed.

**Drip points prevent creeping moisture**

They quickly drain the petticoat in wet weather and insure a dry inner area.

Read the result of tests in booklet "Some Interesting Facts."



No. 72—Voltages—Test—Dry 64000, Wet 31400, Line 10000

## Hemingray Glass Company

TRADE MARK  
**HEMINGRAY**  
REGISTERED

Established 1848  
Incorporated 1870

Covington, Ky.  
Factories: Muncie, Indiana

Company ad.

Electric Railway Journal

18 Mar 1916

(Courtesy of Elton Gish)



# HEMINGRAY



---

MADE IN SIZES UP TO 15000 VOLTS

---

***Service:*** Based on 60 years of glass-making experience devoted to the production of glass insulators. More than 25 years' experience with medium-voltage insulators and hundreds of installations to support our claims that glass possesses greater economies for medium-voltage lines. Send for copies of our Bulletins.

Est. 1848 — Inc. 1870

**HEMINGRAY GLASS COMPANY**

Muncie, Ind., U. S. A.

Company ad.

The Electrical World

27 Dec 1924

(Courtesy of Elton Gish and Bob Stahr)

YES



# Glass

—UP TO  
15,000  
VOLTS

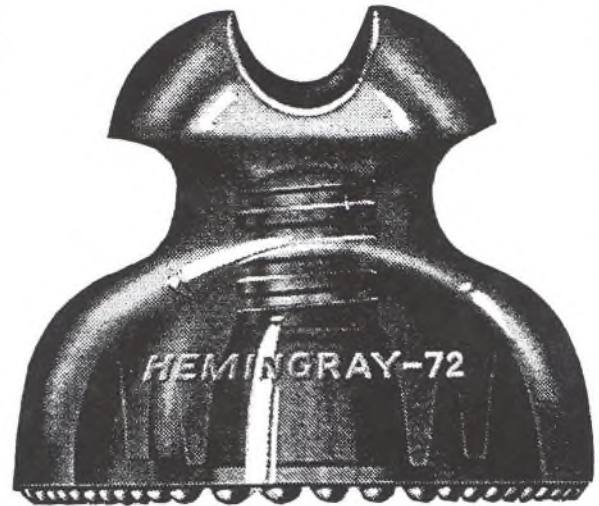

There are five good reasons—each one a valid reason for using Hemingray glass insulators on all of your medium voltage lines—Get our catalog—it explains them fully.

# HEMINGRAY

**HEMINGRAY GLASS COMPANY**

General Offices and Factory

Muncie, Indiana

Company ad.  
Electric Railway Journal  
Dec 1930  
(Courtesy of Elton Gish)



*For medium  
voltage ~  
insulate with*  
**GLASS**

BEST  
UP  
TO  
15,000  
VOLTS

*Let us tell  
you why*

Send for  
Catalog.



**HEMINGRAY**

**HEMINGRAY GLASS COMPANY**

General Offices and Factory

Muncie, Indiana

Company ad.  
Electric Railway Journal  
Jun 1931  
(Courtesy of Elton Gish)



**NOW** Hemingray advantages  
include

# BRASS BUSHING

● Hemingray's 40 years of insulator experience plus 60 years of Owens-Illinois experience in all types of glass fabrication culminates in the announcement of the new Brass Bushed Insulator. Brass Bushing affords greater mechanical strength with more economy and dependability than ever before. The metal pin hole provides uniformity and is protection against possible damage from pin expansion.

The three principal insulator requisites for efficient distribution service—dielectric strength, mechanical strength and resistance to heat shock are all built into the new line of Hemingray Insulators with more than ample reserve. This is proven by more than 18,000 tests of all types of insulators under varying conditions. For further details on this new insulator, send for samples and descriptive folder.

Owens-Illinois Glass Company, Hemingray Division, Muncie, Ind.

## Study these Hemingray glass INSULATOR FEATURES

- |   |  |
|---|--|
| 1 Brass Bushed Smooth threads for insulator pin | 6 Never age or deteriorate                     |
| 2 Greater mechanical strength                   | 7 Controlled uniformity of product             |
| 3 Sustained high dielectric strength            | 8 All surfaces impervious to moisture          |
| 4 Unaffected by sudden temperature changes      | 9 Tougher—improved—withstanding rough handling |
| 5 Withstand maximum insulator pin expansion     | 10 Clear and flawless for easy inspection      |

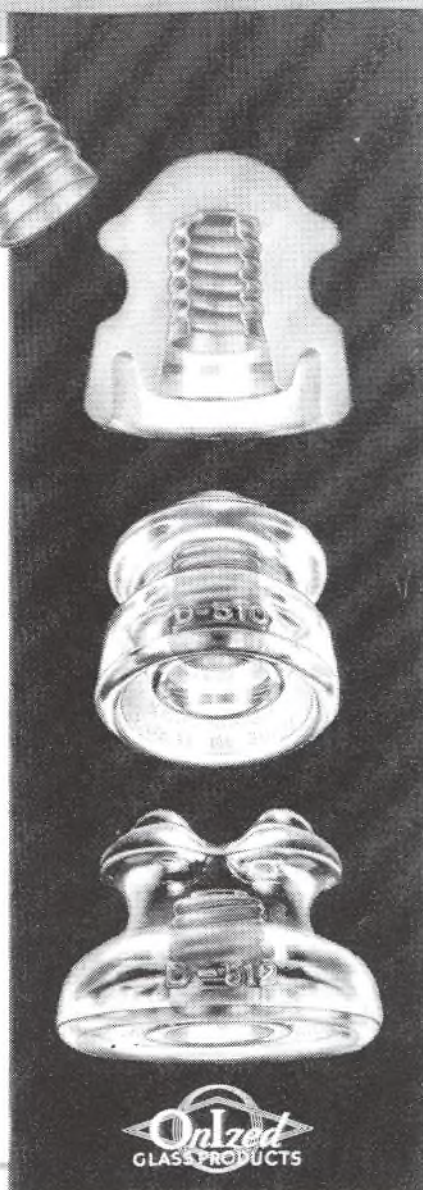

HEMINGRAY *Glass* INSULATORS

Owens-Illinois color ad for D-series insulators  
with brass bushings.

Electrical West

Jun 1935

(Courtesy of Mr. N. R. Woodward)



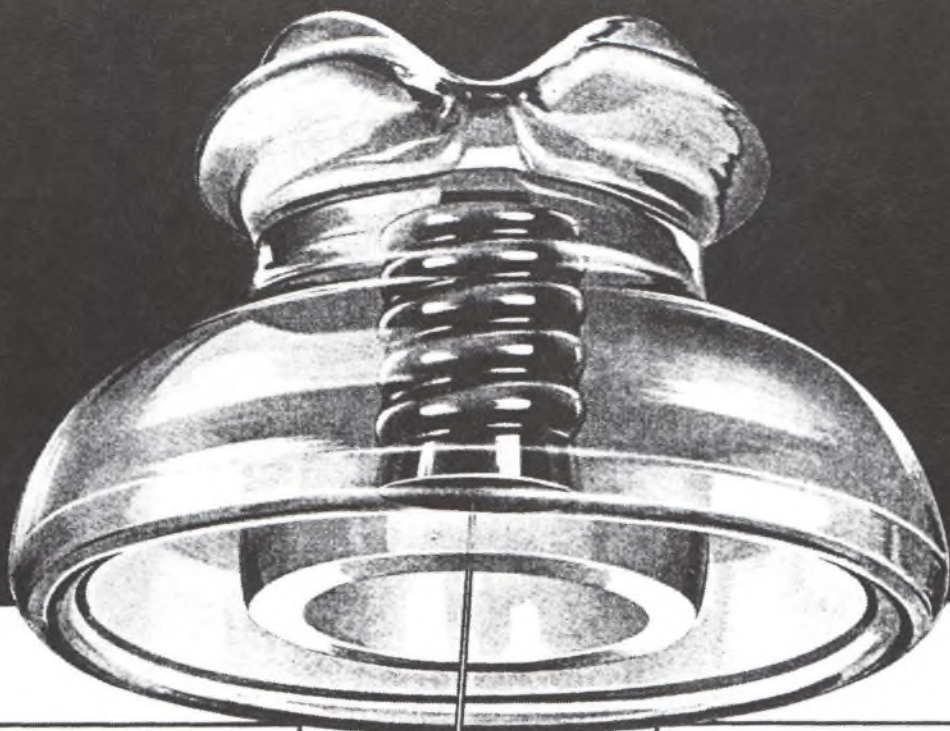

That brass bushing eliminates all the old troubles caused by pin expansion"

—DISTRIBUTION ENGINEER

"And it saves us plenty of worry, and money too, because it makes Hemingray extra tough"—GENERAL MANAGER

Operatives and officials both agree on Hemingray Brass-Bushed Glass Insulators because they render efficient service at reasonable cost and are available in quantities needed, at short notice. Hemingrays for distribution and rural power lines fulfill the requirements of the most exacting user. Their performance in service backs up the judgment of the man who buys them. Order some today from your jobber, or write for samples and prices. Owens-Illinois Glass Company, Hemingray Division, Muncie, Ind.



- ◆ Brass-bushed for greater strength, perfect threads and full protection against pin expansion.
- ◆ Hemingray provides many advantages: greater mechanical strength . . . sustained dielectric strength . . . unaffected by sudden temperature changes . . . withstands maximum insulator pin expansion . . . never ages or deteriorates . . . controlled uniformity of product . . . all surfaces impervious to moisture . . . tougher— withstands rough handling . . . clear, flawless for easy inspection. Ratings up to 15,000 volts.

**FOR MODERN POWER LINE INSULATION**

*Order* **HEMINGRAY <sup>glass</sup> INSULATORS**

Company ad.

The Electrical World  
19 Jun 1937

(Courtesy of Bob Stahr and Elton Gish)

# The Result

## OF 18,000

## TESTS



◆ The high efficiency of Hemingray Brass-Bushed Glass Insulators, their dependability, extra-long life, and low cost are the direct result of exhaustive research, accompanied by more than 18,000 of the most rigorous tests you can imagine, and followed by extensive manufacturing development.

There was no guesswork in developing this modern insulator, and there is no guesswork in its manufacture, for precision process control and continuous inspection and testing mean product uniformity that assures wholly satisfactory performance.

If you are not now using Hemingrays, order some today from your jobber or write to us for samples. Subject them to the most gruelling tests you know of and see for yourself how they can take it. Make Hemingrays prove to you that their performance in service backs up the judgment of the man who buys them. They're available in clear or brown glass and in ratings up to 15,000 volts. Owens-Illinois Glass Company, Hemingray Division, Muncie, Indiana.

- ◆ Brass-bushed for greater strength, perfect threads and full protection against pin expansion.
- ◆ Hemingray provides many advantages: greater mechanical strength . . . sustained dielectric strength . . . unaffected by sudden temperature changes . . . withstands maximum insulator pin expansion . . . never ages or deteriorates . . . controlled uniformity of product . . . all surfaces impervious to moisture . . . tougher— withstands rough handling . . . clear, flawless for easy inspection.

**FOR MODERN POWER LINE INSULATION**  
*Order* **HEMINGRAY  INSULATORS**

Company ad.

The Electrical World

3 Jul 1937

(Courtesy of Bob Stahr and Elton Gish)





**HEMINGRAY PRESENTS**  
 ...AN IMPROVED "HIGH-LEAKAGE  
 DISTANCE" GLASS INSULATOR OF  
**SUPERIOR QUALITY**  
 FOR PRIMARY DISTRIBUTION  
 POWER LINES....

• These new series 600, tough, electrical glass insulators, are designed to render lasting low-cost service under all conditions—and save money for the user.

Three sizes, moderately priced, handle all normal distribution line needs from

2300 to 15,000 volts. . . They are brass-bushed to insure perfect threads and better performance on the line.

Manufacturing processes are more accurately controlled than ever possible in the past, resulting in uniform production and a superior product.

Large stocks carried—prompt deliveries. . . Send for samples today.

OWENS-ILLINOIS GLASS COMPANY • HEMINGRAY DIVISION • MUNCIE, INDIANA

**FOR MODERN POWER LINE INSULATION**

*Order*

**HEMINGRAY  INSULATORS**

Company ad.

The Electrical World

1 Jan 1938

(Courtesy of Bob Stahr and Elton Gish)





*That smooth, uniform*  
**BOLT HOLE** *means*  
*lasting economy!*

● Beginning with low first cost, the Hemingray Spool-Type Glass Insulator, now bushed with the new Lead Sleeve, remains in the strict economy class. Besides the inherent qualities of glass, this spool-type insulator offers many new advantages because of the Lead Sleeve. It withstands 4200 pounds lateral pull for greatest dependability. The stress is distributed over a large bearing area. There are no high spots or single point contacts with bolt. This eliminates many maintenance troubles . . . Remember, too, that glass does not deteriorate, absorb moisture, puncture, or contain hidden flaws or voids. Write for sample and full information.

Owens-Illinois Glass Company, Hemingray Division, Muncie, Indiana.

The *New* Hemingray Spool-Type Insulator lined with a *Lead Sleeve* adds uniformity to the high mechanical strength of each insulator.

Obtainable  
in clear and  
brown glass



*"First in Glass"*

*Order*  
**OWENS-ILLINOIS HEMINGRAY INSULATORS**  
*For modern power line insulation*

Company ad.  
The Electrical World  
21 May 1938  
(Courtesy of Bob Stahr and Elton Gish)



# Five detours ON A 12½ INCH TRIP!



"Old Man Outage" just can't get anywhere—there are too many detours and the road is too hazardous for him to travel far.

Regardless of the weather's severity, the unusually long leakage distance of the Series-600 Hemingray Insulators is a guarantee of outage-free performance. Modern design, combined with tough, ageless HEMINGRAY electrical glass and the considerably greater mechanical strength provided by the brass bushing, means long, faithful service.

The Series-600 provide lower initial and over-all costs. Specify them. . . Ask for samples, test them and learn their greater service advantages. Owens-Illinois Glass Company, Hemingray Division, Muncie, Indiana.

**3 SIZES**  
 TYPE 660 . . . . . FOR VOLTAGES UP TO 8,000  
 TYPE 670 . . . . . FOR VOLTAGES UP TO 10,000  
 TYPE 680 . . . . . FOR VOLTAGES UP TO 15,000  
 Handle most PRIMARY line requirements

© World's largest manufacturers of glass containers; and producers of INSULUX Glass Block, DUST-STOP Replacement-Type Air Filters; FIBERGLAS Insulating Wool, Insulating Blankets and Electrical Insulation.

*Order* **HEMINGRAY** *etc.* **INSULATORS**  
*For modern power line insulation*  
**Made by OWENS-ILLINOIS** *'First in Glass'*

Company ad.  
The Electrical World  
 4 Jun 1938  
 (Courtesy of Bob Stahr and Elton Gish)



**COSTS GO DOWN**  
*when Hemingrays*  
**GO UP!**

**3 SIZES**  
 TYPE 660 . . . FOR VOLTAGES UP TO 8,000  
 TYPE 670 . . . FOR VOLTAGES UP TO 10,000  
 TYPE 680 . . . FOR VOLTAGES UP TO 15,000  
*Handle most PRIMARY line requirements*

● There's no doubt about it! The modern design of the Series-600 HEMINGRAY Insulators provides the greater leakage distance that assures outage-free performance at all times. The brass bushing means greater mechanical strength. . . . The tougher glass defies age and offers resistance to harder usage. The more accurately controlled manufacturing processes mean uniform production. These four advantages added together mean unfailing service, lower costs throughout the years. . . . Send today for test samples. Prove to yourself, as others have, the many HEMINGRAY advantages. . . . Owens-Illinois Glass Company, Hemingray Division, Muncie, Indiana.

● World's largest manufacturers of glass containers; and producers of INSULUX Glass Block; DUST-STOP Replacement-Type Air Filters; FIBERGLAS Insulating Wool, Insulating Blankets and Electrical Insulation.

**HEMINGRAY INSULATORS**  
**OWENS-ILLINOIS GLASS COMPANY**  
*"First in Glass"*

Company ad.

The Electrical World  
 19 Nov 1938

(Courtesy of Bob Stahr and Elton Gish)



## GLASS INSULATORS.

### SPECIAL COLORED GLASS INSULATORS.

Where several lines of different companies are on the same cross arm the lineman can distinguish his line by the color of the insulator. Different currents can also be designated by different colored insulators. We are prepared to furnish all styles of insulators in red, blue, and amber glass, but shipments can be made direct from the factory only.

Trade  
No.

Code Word.

4261 Add per M for colored glass.....\$8.00 net. Moresque

All insulators are furnished regularly and carried in stock only in green glass and green glass will always be shipped unless otherwise specified.



No. 486. 1/2 actual size.

### DEEP GROOVE, DOUBLE PETTICOAT.

Weight per piece, 20 ounces; weight per 1,000 packed, 1,400 pounds. Packed 200 in a barrel.

Trade  
No.

Code Word.

486 Per 1,000 .....\$84.40 Brimstone

### STREET RAILWAY, EXTRA DEEP GROOVE, DOUBLE PETTICOAT.

TAKES THREE-FOURTHS INCH CABLE.

Weight per piece, 20 ounces; weight per 1,000 packed, 1,400 pounds. Packed 200 in a barrel.

Trade  
No.

Code Word.

487 Per 1,000 .....\$84.40 Briskly



No. 487. 1/2 actual size.



No. 485. 1/2 actual size.

### STANDARD DEEP GROOVE.

Weight per piece, 17 ounces; weight per 1,000 packed, 1,200 pounds. Packed 250 in a barrel.

Trade  
No.

Code Word.

485 Per 1,000 .....\$68.80 Brindled

This page and the following 6 pages are from  
the Electric Appliance Co. catalog.  
1909-1910

(Courtesy of Elton Gish)

**REGULAR OR No. 3.**

Weight per piece, 15¼ ounces; weight per 1,000 packed, 1,120 pounds. Packed 250 in a barrel.

Trade No.		Code Word.
484	Per 1,000 .....	\$62.00 Briskness



No. 484. ¼ actual size



No. 11975.  
One-half Actual Size.

**W. U. DOUBLE PETTICOAT INSULATOR.**

Weight per piece, 22 ounces; weight per 1,000 packed, 1,575 pounds Packed 200 in a barrel.

Trade No.		Code Word.
11975	Per 1,000 .....	\$91.30 Goujeers

**DEEP GROOVE, DOUBLE PETTICOAT, PONY**

FOR TELEPHONE AND LIGHT ELECTRIC LIGHT WIRING.

Weight per piece, 11½ ounces; weight per 1,000 packed, 930 pounds. Packed 300 in a barrel.

Trade No.		Code Word.
5268	Per 1,000 .....	\$54.00 Mousehole



No. 5268.  
One-half Actual Size.



No. 6625.  
One-half Actual Size.

**LONG DISTANCE REGULAR.**

Weight per piece, 16 ounces; weight per 1,000 packed, 1,000 pounds. Packed 300 in a barrel.

Trade No.		Code Word.
6625	Per 1,000 .....	\$61.20 Reputable





No. 483.  
One-half Actual Size.

### No. 9 PONY INSULATOR.

Weight per piece, 10 ounces; weight per 1,000 packed, 765 pounds.  
Packed 400 in a barrel.

Trade		Code Word.
No.		
483	Price per 1,000 .....	\$38.70 Bristle

### No. 12 DOUBLE GROOVE PONY INSULATOR.

Weight per piece, 10 $\frac{3}{4}$  ounces; weight per 1,000 packed, 765 pounds. Packed 400 in a barrel.

Trade		Code Word.
No.		
4262	Price per 1,000 .....	\$38.70 Mounted



No. 4262.

### No. 4 PONY INSULATOR.

FOR TELEPHONE.

Not carried in Chicago stock.

Weight per piece, 10 $\frac{1}{2}$  ounces; weight per 1,000 packed, 825 pounds.  
Packed 300 in a barrel.



No. 11977.  
One-half Actual Size.

Trade		Code Word.
No.		
11977	Price per 1,000 .....	\$41.50 Gouland

### DOUBLE GROOVE INSULATOR.

Not carried in Chicago stock.

Weight per piece, 19 ounces; weight per 1,000 packed, 1,350 pounds.  
Packed 200 in a barrel.

Trade		Code Word.
No.		
11978	Price per 1,000 .....	\$91.30 Goule



No. 11978.  
One-half Actual Size.



No. 6626

**DEEP GROOVE DUPLEX INSULATOR.**

Trade No. 6626 Per 1,000 .....\$84.40 Code Word. Repulsiveness

**PONY DUPLEX INSULATOR.**

Trade No. 6992 Price per 1,000 .....\$76.00 Code Word. Rudder



No. 6992.

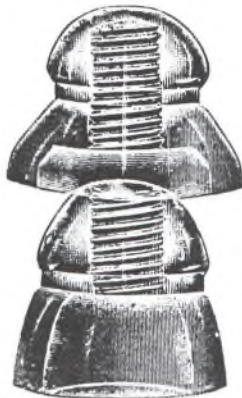

**TWO-PIECE TRANSPOSITION.**

Weight per piece, 30 ounces; weight per 1,000, 2,000 pounds. Packed 125 in a barrel.

Trade No. 11979 Per 1,000 .....\$267.00 Code Word. Goules

No. 11979. One-half actual size.

**REGULAR TRANSPOSITION INSULATOR.**

Weight per piece, 31 ounces; weight per 1,000, 2,400 pounds. Packed 100 in a barrel.

Trade No. 4263 Per 1,000 .....\$168.70 Code Word. Mountebank



No. 4263. One-half actual size.



No. 13336.

**TRANSPOSITION INSULATOR.**

**NO. 2.**

Weight per piece, 28 ounces; weight per 1,000, 1750 pounds. Packed 125 in a barrel.

Trade No. 13336 Per 1,000 .....\$168.70 Code Word. Cocktail





No. 4264. 3/4 Actual Size.

### CABLE INSULATOR.

Weight, per piece, 30 ounces; weight, per 1,000 packed, 2,330 pounds. Packed 100 in a barrel.

Trade No.		Code Word.
4264	Price per 1,000 .....	\$154.70 Mountain

### No. 1 HIGH VOLTAGE INSULATOR.



No. 6629.

Triple petticoat. Guarantee 10,000 volts. Weight, per piece, 31 ounces, weight, per 1,000 packed, 2,330 pounds. Packed 100 in a barrel. 3 3/4 inches high, 4 1/4 inches diameter. All shipments made from Muncie, Ind.

Trade No.		Code Word.
6629	Price per 1,000 .....	\$225.00 Reputably

### No. 2 HIGH VOLTAGE, TRIPLE PETTICOAT INSULATOR.

Guarantee 15,000 volts. Weight, per piece, 32 ounces; weight, per 1,000 packed, 2,600 pounds. Packed 100 in a barrel. 4 inches high, 4 3/4 inches diameter. All shipments made from Muncie, Ind.

Trade No.		Code Word.
11980	Price per 1,000 .....	\$380.00 Goune

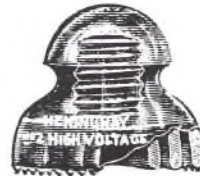

No. 11980.

### No. 0 PROVO TYPE.

Four petticoats. Guarantee, 50,000 volts. Weight, per piece, 8 1/4 pounds. Height, 6 1/2 inches; diameter, 8 1/2 inches. Weight, per 1000 packed, 11,120 lbs. Packed 18 in a barrel. All shipments made from Muncie, Ind.

Trade No.		Code Word.
1790	Price each .....	\$1.00 Notion

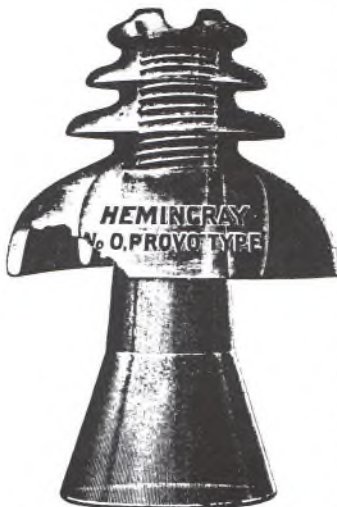

Nos. 1790 and 1791. Assembled. 1791 Price each .....\$0.70 Notional

### GLASS SLEEVE FOR PROVO INSULATOR.

This Sleeve is to be used in connection with No. 0 Provo Insulator for 50,000 volts, and is intended to slip over special "treated" pin. Specifications covering pins furnished upon application. Sleeve weighs 4 pounds each. Weight per 1,000 packed, 5,400 pounds. Packed 32 in a barrel. All shipments made from Muncie, Ind.

Trade No.		Code Word.
1791	Price each .....	\$0.70 Notional

## "PROVO" HIGH POTENTIAL INSULATOR.



No. 6627.



No. 6628.

### No. 1 "PROVO" TYPE.

Triple petticoat. Designed for high voltage power transmission. Guarantee, 40,000 volts. Weight, per 1,000 packed, 7,350 pounds. Weight,  $5\frac{7}{16}$  pounds; height,  $5\frac{1}{2}$  inches; diameter, 7 inches. Packed 25 in a barrel. All shipments made from Muncie, Ind.

Trade				Code Word.
No.				Repurchase
6627	Price per 1,000	-----	\$600.00	

### No. 2 "PROVO" TYPE.

Triple petticoat. Guarantee 25,000 volts. Weight, per piece,  $45\frac{1}{2}$  ounces; height,  $4\frac{3}{4}$  inches; diameter,  $5\frac{1}{2}$  inches; weight, per 1,000 packed, 3,600 pounds. Packed 65 in a barrel. All shipments made from Muncie, Ind.

Trade				Code Word.
No.				Reputableness
6628	Price per 1,000	-----	\$450.00	

## GLASS INSULATING KNOBS.



No. 488.



No. 4266.



No. 489.

### No. 1 INSULATING OR BREAK KNOB.

$1\frac{1}{2}$  inch long;  $1\frac{1}{2}$  inch wide;  $\frac{3}{8}$  inch hole. Weight, per piece, 3 ounces; weight per 1,000 packed, 220 pounds. Packed 500 in a keg.

Trade				Code Word.
No.				Broach
488	Price per 1,000	-----	\$30.90	

### No. 1 $\frac{1}{2}$ INSULATING OR BREAK KNOB.

$1\frac{3}{8}$  inch long;  $1\frac{1}{2}$  inch wide;  $\frac{3}{8}$  inch hole. Weight, per piece,  $3\frac{1}{2}$  ounces; weight, per 1,000 packed, 250 pounds. Packed 500 in a keg.

Trade				Code Word.
No.				Mouldiness
4266	Price per 1,000	-----	\$37.30	

### No. 2 INSULATING OR BREAK KNOB.

$1\frac{3}{4}$  inch long; 2 inch wide;  $\frac{3}{8}$  inch hole. Weight, per piece,  $6\frac{1}{2}$  ounces; weight per 1,000 packed, 510 pounds. Packed 500 in a barrel.

Trade				Code Word.
No.				Broadside
489	Price per 1,000	-----	\$49.30	



## GLASS INSULATING BREAK KNOBS.



No. 11981.



No. 4267.

## No. 3 INSULATING OR BREAK KNOB.

For insulating span wires, guy wires, arc lamps, etc.  $2\frac{1}{2}$  inch long, 2 inch wide,  $\frac{3}{8}$  inch hole. Weight per piece, 7 ounces; weight per 1,000 packed, 530 pounds. Packed 500 in a barrel.

Trade No.	Price per 1,000	Code Word.
11981	\$49.30	Gour

## No. 7 INSULATING OR BREAK KNOB.

$2\frac{1}{2}$  inch long, 2 inch wide,  $\frac{3}{8}$  inch hole. Weight per piece, 7 ounces; weight per 1,000 packed, 530 pounds. Packed 500 in a barrel.

Trade No.	Price per 1,000	Code Word.
4267	\$49.30	Moulting

## GLASS SPAN WIRE INSULATORS.



No. 10.

Weight per piece, 12 ounces; weight per 1,000 packed, 720 pounds. Packed 500 in a barrel.

Trade No.	Price per 1,000	Code Word.
11984	\$156.00	Gourd

## No. 15.

Weight per piece,  $17\frac{1}{2}$  ounces; weight per 1,000 packed, 1,260 pounds. Packed 250 in a barrel.

Trade No.	Price per 1,000	Code Word.
14727	\$225.00	Daybreak

HEMINGRAY GLASS INSULATORS

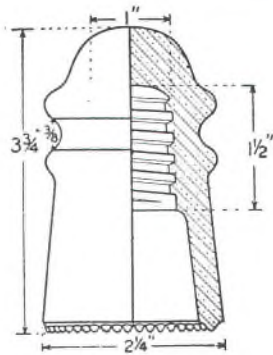

No. 9

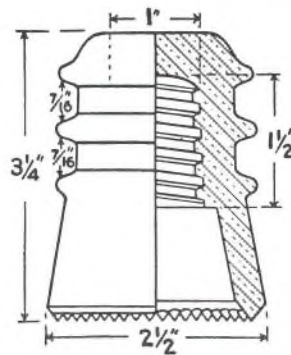

No. 10

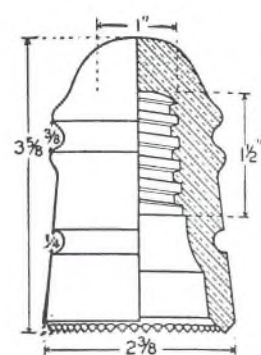

No. 12

List No.	Mfr. No.	Description	Diam. Groove	Weight Each	Wt. per 1000 Packed	Std. Pkg. Quantity
700171	9	Pony .....	3/8 in.	9 ozs.	675 lbs.	400
700172	10	Exchange Line .....	7/16 in.	10 ozs.	720 lbs.	350
700173	12	Double Groove Pony .....	3/8 in.	10 1/2 ozs.	750 lbs.	400

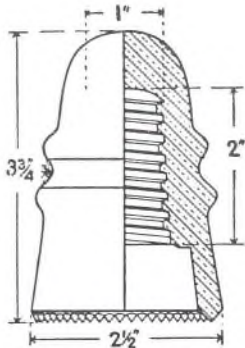

No. 13  
(Old No. 4)

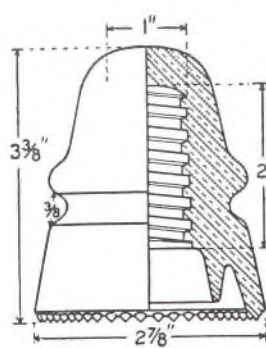

No. 14

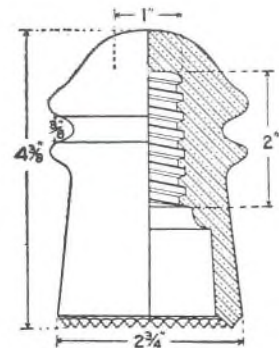

No. 15  
(Old No. 5)

700174	13	National Pony .....	3/8 in.	11 ozs.	825 lbs.	300
700175	14	Deep Groove Double Petticoat Pony .....	3/8 in.	11 1/2 ozs.	865 lbs.	300
700176	15	Western Union .....	3/8 in.	20 ozs.	1450 lbs.	200

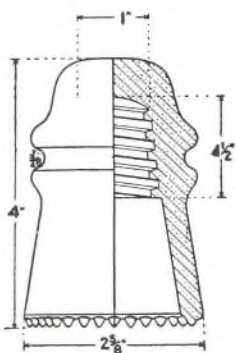

No. 16

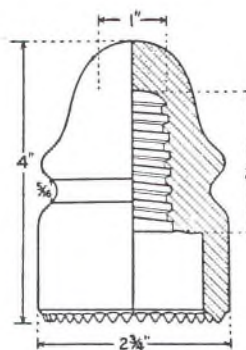

No. 17  
(Old No. 3)

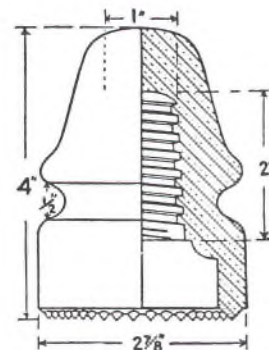

No. 18

700177	16	Long Distance .....	3/8 in.	14 ozs.	1000 lbs.	300
700178	17	Regular .....	7/16 in.	15 1/2 ozs.	1120 lbs.	250
700179	18	Deep Groove .....	1/2 in.	17 ozs.	1200 lbs.	250

Prices on application. Weights given are approximate.

Insulators

27

This page and the following 4 pages are from  
the Western Electric catalog.

1915

(Courtesy of Elton Gish)

211



HEMINGRAY GLASS INSULATORS

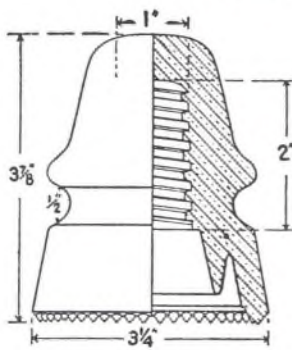

No. 19

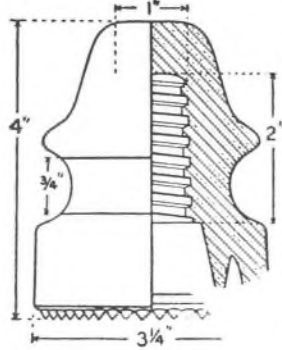

No. 20

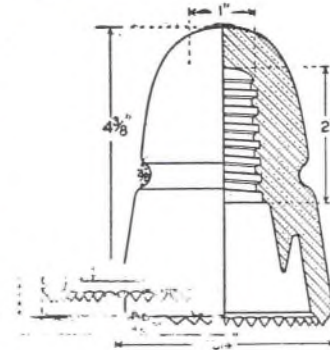

No. 21

List No.	Mfr. No.	Description	Diam. Groove	Weight Each	Wt. per 1000 Packed	Std. Pkg. Quantity
700180	*19	Deep Groove, Double Petticoat. . . . .	1/2 in.	19 ozs.	1350 lbs.	200
700181	20	Street Railway or Extra Deep Groove, Double Petticoat. . . . .	3/4 in.	20 ozs.	1400 lbs.	200
700182	21	Standard W. U. Double Petticoat. . . . .	3/8 in.	22 ozs.	1550 lbs.	200

\* Also made in Amber, Blue, and Crystal Colors.

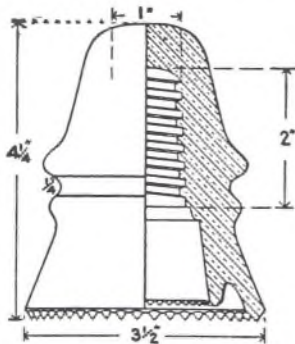

No. 22

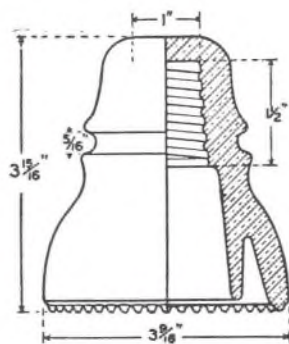

No. 40

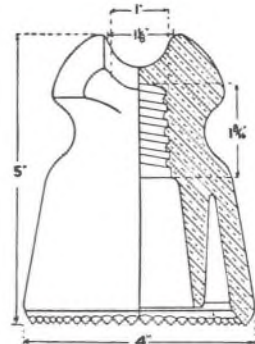

No. 41

700183	22	Western Union Double Petticoat Teat. . . . .	1/4 in.	21 ozs.	1520 lbs.	200
700184	40	Double Petticoat, new W. U. standard. . . . .	5/8 in.	22 ozs.	1550 lbs.	200
700185	41	Long Double Petticoat. . . . .	1 1/8 ins.	38 ozs.	2750 lbs.	100

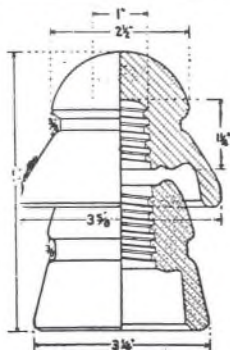

No. 50

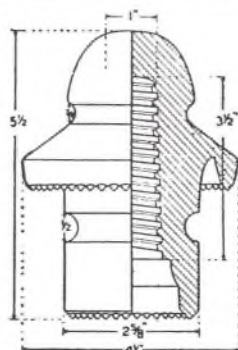

No. 51  
(Old No. 1)

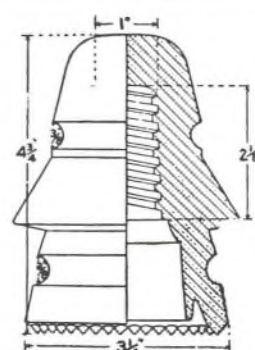

No. 52  
(Old No. 2)

700186	50	Two-piece Transposition . . . . .	3/8 in.	25 ozs.	1950 lbs.	125
700187	51	Perfect Transposition . . . . .	3/8 in.	34 ozs.	2500 lbs.	100
700188	52	Transposition. . . . .	3/8 in.	28 ozs.	2100 lbs.	125

Prices on application. Weights given are approximate.

HEMINGRAY GLASS INSULATORS

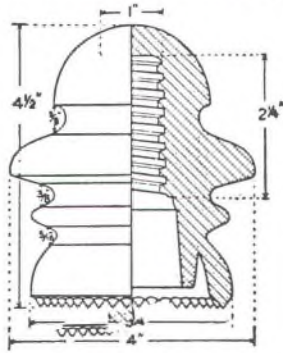

No. 53  
(Old Locke No. 14)

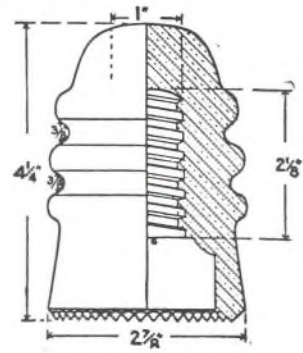

No. 54

List No.	Mfr. No.	Description	Diam. Groove	Weight Each	Wt. per 1000 Packed	Std. Pkg. Quantity
700189	53	Transposition.....	3/8 in.	30 ozs.	2250 lbs.	100
700190	54	Large Double Groove.....	3/8 in.	20 ozs.	1375 lbs.	200

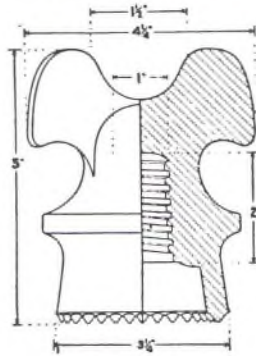

No. 60

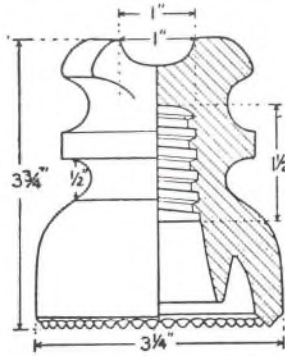

No. 61  
(Old No. 1)

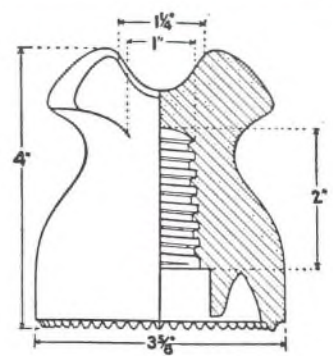

No. 62  
(Old No. 2)

700191	60	Cable.....	1 1/2 ins.	30 ozs.	2300 lbs.	100
700192	60A	Cable—same design as No. 60.....	2 ins.	30 ozs.	2300 lbs.	100
700193	61	Cable.....	1 ins.	18 ozs.	1450 lbs.	200
700194	62	Cable.....	1 1/4 ins.	30 ozs.	2100 lbs.	125

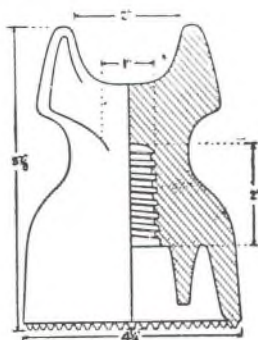

No. 63  
(Old No. 3)

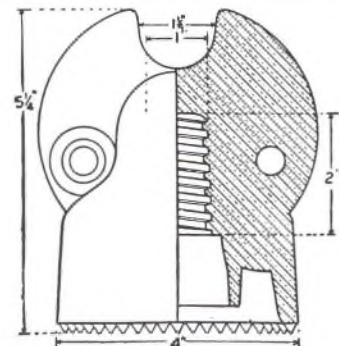

No. 64

700195	63	Cable.....	2 ins.	48 ozs.	3600 lbs.	65
700196	64	Columbia Double Petticoat.....	1 1/4 ins.	40 ozs.	2800 lbs.	100

Prices on application. Weights given are approximate.



HEMINGRAY GLASS INSULATORS

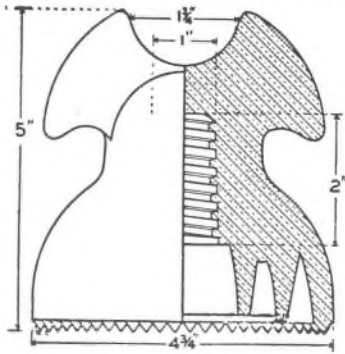

No. 70

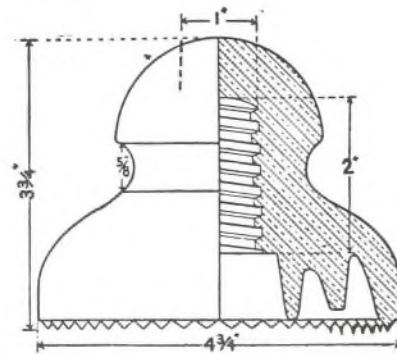

No. 71  
(Old No. 1)

List No.	Mfr. No.	Description	Voltages			Diam. Groove	Weight Each	Wt. per 1000 Packed	Std. Pkg. Quantity
			Line	Dry Test	Wet Test				
700197	70	High Potential Triple Petticoat Cable.....	10000	61900	37800	1 3/4 ins.	43 ozs.	3150 lbs.	65
700198	71	High Voltage.....	10000	58400	31000	5/8 in.	32 ozs.	2500 lbs.	100

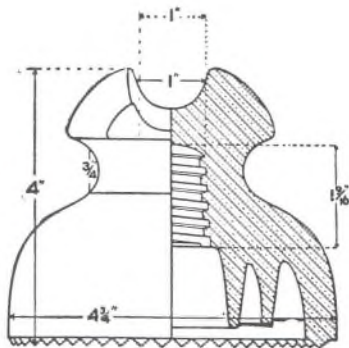

No. 72  
(Old No. 4)

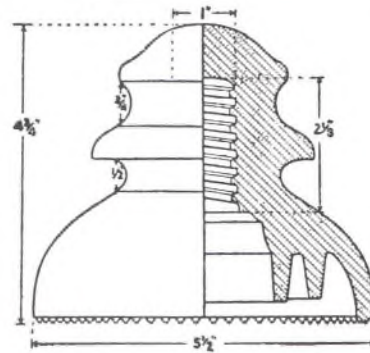

No. 73  
(Old No. 2)

700199	72	High Voltage.....	10000	64000	31400	1 in.	35 ozs.	2700 lbs.	100
700200	73	Provo.....	15000	74400	43800	3/4 in.	47 ozs.	3600 lbs.	60

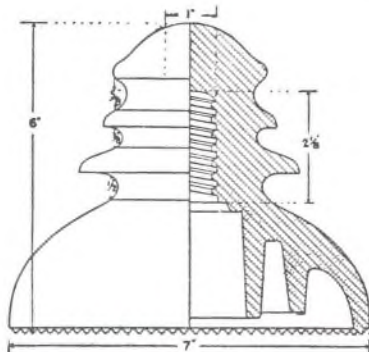

No. 74  
(Old No. 1)

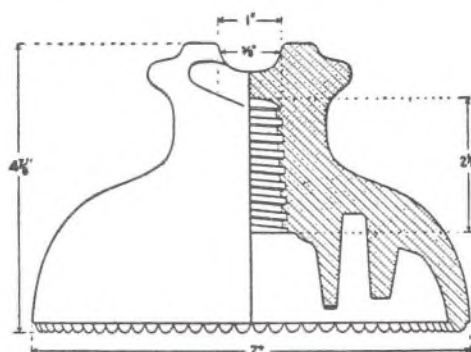

No. 75

700201	*74	Provo.....	19000	93700	55200	5/8 in.	5 1/4 lbs.	7000 lbs.	25
700202	*75	7 Inch Muncie.....	17000	86200	50100	7/8 in.	4 3/4 lbs.	6200 lbs.	30

\* Made for 1 inch and 1 3/8 inch screws. Weights given are approximate. Prices on application.

HEMINGRAY GLASS INSULATORS

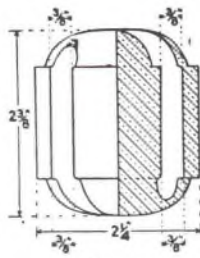

No. 90

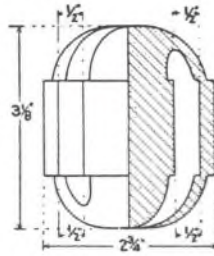

No. 91

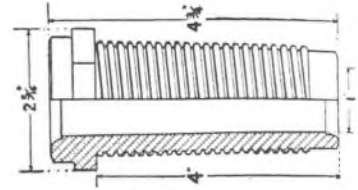

Floor Tube

SPAN WIRE INSULATORS

List No.	Mfr. No.	Description	Crushing Strength	Diam. Groove	Weight Each	Wt. per 1000 Packed	Std. Pkg. Quantity
700203	90	Span wire (Old No. 10)	4912 lbs.	3/8 in.	11 ozs.	700 lbs.	500
700204	91	Span wire (Old No. 15)	5910 lbs.	1/2 in.	17 1/2 ozs.	1260 lbs.	250

FLOOR TUBES

List No.	Mfr. No.	Length Inches	Bore Inches	Description	List No.	Mfr. No.	Length Inches	Bore Inches	Description
700205	120	2 1/2	3/4	With screw	700212	127	4	1	With screw
700206	121	3	1/2	With screw	700213	128	4 1/2	1	With screw
700207	122	3	1	With screw	700214	129	5	1	With screw
700208	123	3	1 1/4	With screw	700215	130	6	1	With screw
700209	124	3 1/2	3/4	Without screw	700216	131	6	1 1/4	With screw
700210	125	3 1/2	1	With screw	700217	132	6	1	Split plain
700211	126	4	3/4	With screw					

GLASS KNOBS AND MINE INSULATOR

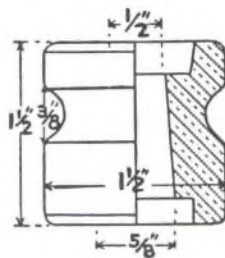

No. 100

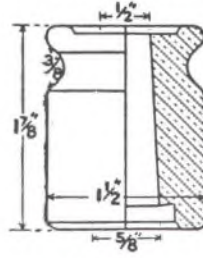

No. 101

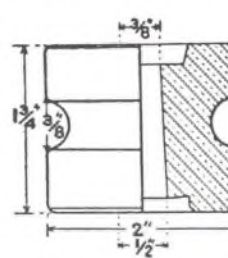

No. 102

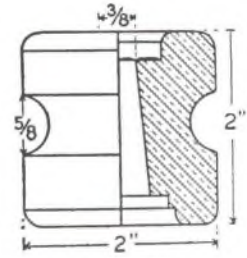

No. 103

List No.	Mfr. No.	Description	Diam. Groove	Weight Each	Wt. per 1000 Packed	Std. Pkg. Quantity
700218	100	Knob (Old No. 1)	3/8 in.	3 ozs.	200 lbs.	500
700219	101	Knob (Old No. 1 1/2)	3/8 in.	3 1/2 ozs.	230 lbs.	500
700220	102	Knob (Old No. 2)	3/8 in.	6 1/2 ozs.	440 lbs.	500
700221	103	Knob (Old No. 3)	5/8 in.	7 ozs.	460 lbs.	500

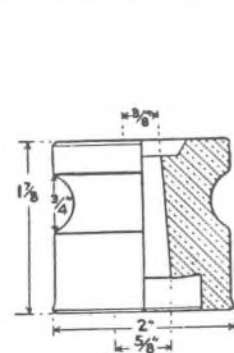

No. 107

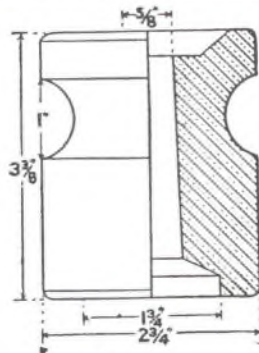

No. 108

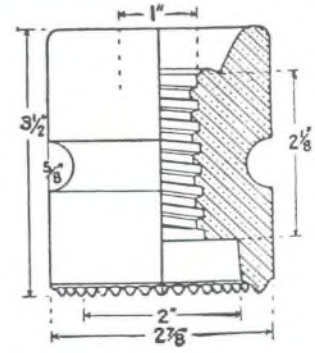

No. 95

700222	107	Knob (Old No. 7)	3/4 in.	7 ozs.	460 lbs.	500
700223	108	Knob (Old No. 8)	1 in.	21 1/2 ozs.	1500 lbs.	200
700224	95	Mine insulator (Old No. 1)	5/8 in.	20 ozs.	1475 lbs.	200

Prices on application. Weights given are approximate.



HEMINGRAY GLASS INSULATORS



No. 9



No. 10



No. 12



No. 13



No. 14

No. 9 PONY



No. 15

Trade No.	DIMENS. OVER ALL, INCHES	Height	Diam.	Groove	Std. Pkg.	Wt., Lbs. per 1000	Price per 1000
03G469		3 $\frac{3}{4}$	2 $\frac{1}{4}$	3 $\frac{3}{8}$	400	675	\$26.00

No. 10 EXCHANGE LINE

83877		3 $\frac{1}{4}$	2 $\frac{1}{2}$	7 $\frac{1}{16}$	350	720	30.00
-------	--	-----------------	-----------------	------------------	-----	-----	-------

No. 12 DOUBLE GROOVE PONY



No. 16

03G470		3 $\frac{5}{8}$	2 $\frac{3}{8}$	3 $\frac{3}{8}$ Top 1 $\frac{1}{4}$ Bot.	400	750	26.00
--------	--	-----------------	-----------------	---	-----	-----	-------

No. 13 NATIONAL PONY (OLD No. 4)

03G468		3 $\frac{3}{4}$	2 $\frac{1}{2}$	3 $\frac{3}{8}$	300	825	28.00
--------	--	-----------------	-----------------	-----------------	-----	-----	-------

No. 14 DEEP GROOVE, DOUBLE PETTICOAT PONY

03G467		3 $\frac{3}{8}$	2 $\frac{7}{8}$	3 $\frac{3}{8}$	300	865	34.00
--------	--	-----------------	-----------------	-----------------	-----	-----	-------



No. 17

No. 15 WESTERN UNION (OLD No. 5)

83878		4 $\frac{3}{8}$	2 $\frac{3}{4}$	3 $\frac{3}{8}$	200	1450	49.00
-------	--	-----------------	-----------------	-----------------	-----	------	-------

No. 16 LONG DISTANCE

03G471		4	2 $\frac{5}{8}$	3 $\frac{3}{8}$	300	1000	37.00
--------	--	---	-----------------	-----------------	-----	------	-------

No. 17 REGULAR (OLD No. 3)

03G463		4	2 $\frac{3}{4}$	5 $\frac{1}{16}$	250	1120	38.00
--------	--	---	-----------------	------------------	-----	------	-------



No. 18

No. 18 DEEP GROOVE

03G464		4	2 $\frac{7}{8}$	1 $\frac{1}{2}$	250	1200	42.00
--------	--	---	-----------------	-----------------	-----	------	-------

This page and the following 2 pages are from the Mid-West Electric Co. catalog.

1918

(Courtesy of Elton Gish)

HEMINGRAY GLASS INSULATORS

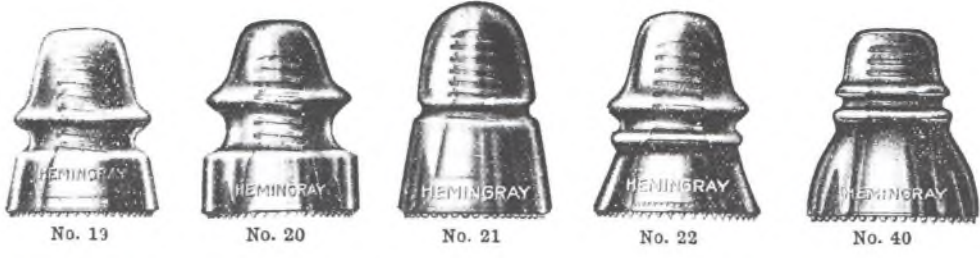

No. 19 DEEP GROOVE, DOUBLE PETTICOAT

Line Voltage, 5000

Trade No.	DIMENS. OVER ALL, INCHES	Height	Diam. Groove	Std. Pkg.	Wt., Lbs. per 1000	Price per 1000
036465	3 7/8	3 1/4	1/2	200	1350	\$50.00

Also made in blue, amber and crystal colors.

No. 20 STREET RAILWAY, OR EXTRA DEEP GROOVE, DOUBLE PETTICOAT

Line Voltage, 5000

036466	4	3 1/4	3/4	200	1375	50.00
--------	---	-------	-----	-----	------	-------

No. 21 WESTERN UNION, DOUBLE PETTICOAT

036462	4 3/8	3 1/4	3/8	200	1550	52.00
--------	-------	-------	-----	-----	------	-------

No. 22 WESTERN UNION, DOUBLE PETTICOAT TEAT

036461	4 1/4	3 1/2	1/4	200	1520	52.00
--------	-------	-------	-----	-----	------	-------

No. 40 DOUBLE PETTICOAT

Line Voltage, 5000

83901	3 5/8	3 3/8	5/8	200	1550	54.00
-------	-------	-------	-----	-----	------	-------

No. 50 TWO-PIECE TRANSPOSITION

036474	5	3 1/4	3/8 Top 3/8 Bot.	125	1950	100.00
--------	---	-------	---------------------	-----	------	--------

No. 51 PERFECT TRANSPOSITION (OLD No. 1)

036472	5 1/2	4 1/4	3/8 Top 1/2 Bot.	100	2500	100.00
--------	-------	-------	---------------------	-----	------	--------

No. 52 TRANSPOSITION (OLD No. 2)

036473	4 3/4	3 1/4	3/8 Top 3/8 Bot.	125	2100	74.00
--------	-------	-------	---------------------	-----	------	-------

No. 53 TRANSPOSITION (OLD No. 14)

83889	4 1/2	4	3/8 Top 5/8 Bot.	100	2250	80.00
-------	-------	---	---------------------	-----	------	-------



HEMINGRAY GLASS INSULATORS



No. 100



No. 101

No. 100 INSULATING OR BREAK KNOBS (OLD No. 1)

Trade No.	DIMENS. OVER ALL, INCHES	Std. Pkg.	Wt., Lbs. per 1000	Price per 1000			
	Height	Diam.	Groove	Hole			
036432	1½	1½	⅜	⅜	500	200	\$21.00

No. 101 INSULATING OR BREAK KNOBS (OLD No. 1½)

036435	1⅞	1½	⅜	⅜	500	230	24.00
--------	----	----	---	---	-----	-----	-------



No. 102



No. 103

No. 102 INSULATING OR BREAK KNOBS (OLD No. 2)

036434	1¾	2	⅜	⅜	500	440	25.00
--------	----	---	---	---	-----	-----	-------

No. 103 INSULATING OR BREAK KNOBS (OLD No. 3)

036433	2	2	⅝	⅜	500	460	25.00
--------	---	---	---	---	-----	-----	-------



No. 107



No. 108

No. 107 INSULATING OR BREAK KNOBS (OLD No. 7)

036436	1⅞	2	¾	⅜	500	460	25.00
--------	----	---	---	---	-----	-----	-------

No. 108 INSULATING OR BREAK KNOBS (OLD No. 8)

036438	3⅜	2¾	1	⅝	200	1500	95.00
--------	----	----	---	---	-----	------	-------

No. 95 MINE INSULATORS (OLD No. 1)

036437	3½	2⅞	⅝	Std. Ser.	200	1475	80.00
--------	----	----	---	-----------	-----	------	-------



No. 95

No. 90 SPAN WIRE INSULATORS (OLD No. 10)

036439	2⅜	2¼	⅜	....	500	700	90.00
--------	----	----	---	------	-----	-----	-------

No. 91 SPAN WIRE INSULATORS (OLD No. 15)

036440	3⅞	2¾	½	....	250	1260	140.00
--------	----	----	---	------	-----	------	--------



No. 90



No. 91

FLOOR INSULATORS

Trade No.	Mfrs. No.	Length Inches	Bore Inches	Style	Price per 1000
036442	121	3	½	Screw	\$83.50
036443	122	3	1	Screw	83.50
036444	123	3	1¼	Screw	100.00
067161	125	3½	1	Screw	94.50
036446	126	4	¾	Screw	117.00
036447	127	4	1	Screw	117.00
036448	128	4½	1	Screw	122.00
036449	129	5	1	Screw	140.00
036450	130	6	1	Screw	161.00
036451	131	6	1¼	Screw	172.00
83866	132	6	1	Split plain	228.00

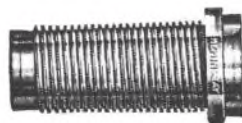

No. 121

The 6-inch split insulators are in two pieces, tongued and grooved, and fit together closely.

TRADE MARK  
 STANDARD HEMINGRAY INSULATORS  
 REGISTERED.

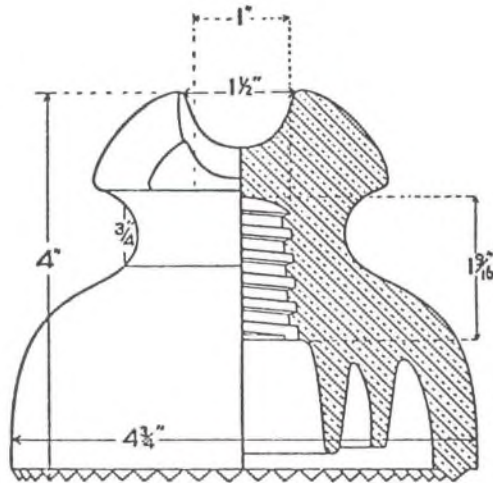

No. 72 High Voltage

This insulator is the same size as the No. 71, but it is made with a top groove instead of a side groove. The records of this particular type are equally as good as the No. 71. Reports from our users do not show failures of any kind.

The voltage recommended for this insulator is 11,000 volts. However, as in the case of the No. 71, its price permits of its use on voltages as low as 6600.

Mfr. No.	Description	Voltages			Leakage Distance	Wet Arcing Distance	Weight Each	Weight Per 1000 Packed	Standard Package Quantity
		Line	Dry Test	Wet Test					
72	High Voltage . . . . .	11000	62000	30000	8 3/4 in.	1 3/4 in.	35 oz.	2700 lbs.	100

Page 8

Page from a Hemingray catalog.  
 Bulletin No. 1  
 15 May 1921  
 (Courtesy of Mike Sovereign and Glenn Drummond)



## GLASS INSULATORS

Some reasons why Glass Insulators should be used on medium voltage Power Lines as well as in the Telegraph and Telephone field where their superiority is firmly established.

Our right to deal with this subject is based on seventy-three years of glass making experience, the last fifty of which have been devoted to the production of glass insulators with a natural accompaniment of improved methods and processes. This period of time, which has been of sufficient length to warrant the drawing of accurate conclusions, has established the fact that glass, by reason of its natural qualities, plus those which can be imparted to it by proper manufacturing methods, has fully met the essential requirements demanded of an insulator operating up to a maximum range of 33,000 volts, which voltage at the present time marks the limit of our experience.

The superiority of glass insulators on low and medium voltage power lines may perhaps be more clearly recognized from a consideration of the requirements of an insulator operating at such ranges together with the manner in which glass has met these requirements.

### DIELECTRIC STRENGTH

One of the very first requirements is that an insulator be made of a material whose specific resistance to the passage of electricity is high. It is a known fact, established by standard tests, that glass is of great dielectric strength. Consequently, glass possesses this necessary quality which must be inherent in an insulating material.

### MECHANICAL STRENGTH

A further requisite of the insulator is that it be possessed of sufficient mechanical strength to withstand temperature changes and blows. The natural improvements of process, spoken of before, have qualified glass to meet this requirement. That point of supreme importance in glass manufacture, annealing, is emphasized here. We have the most modern annealing ovens and governing apparatus obtainable. Furthermore, our fifty years of experience has taught us *not to accept for manufacture a design which can not be properly annealed*. This is one basic reason for the uniform success of our insulators.

### FREEDOM FROM DETERIORATION AND AGING

An insulator should be made of a material which is unaffected by the action of the elements and one whose dielectric strength is not lessened by the lapse of time, for, unless this be the case, deterioration results and with deterioration comes loss of efficiency and finally, failure. Therefore, an insulator should be composed of a material which is homogeneous in character, rather than from a substance composed of two or more materials. Substances composed of two or more materials, each with a different coefficient of expansion, are naturally subject to conflicting strains induced by the natura

This page and the following 2 pages are from  
a Hemingray catalog.  
Bulletin No. 1  
15 May 1921  
(Courtesy of Mike Sovereign)

Page 1

## GLASS INSULATORS—Continued

forces of heat and cold, which, glass, a homogeneous material with but one co-efficient of expansion, is not subject to. Glass insulators after forty years of known service have been found free from any signs of aging or deterioration.

### NON-PORUS

Insulating material should be non-porus. Absorption of water would not only lower its dielectric strength, but would render the substance susceptible to the disruptive effects of freezing. Glass is impervious to water and, therefore, free from this defect.

### TRANSPARENT

A most important requirement of an insulator is that it be transparent. Glass is transparent. Transparency makes the inspection problem of the manufacturer infinitely simpler than it would be were he dealing with an opaque material. Flaws and minute defects which might cause early failure (with resultant interruption of service) can be easily detected. This advantage accompanies the glass insulator to the scene of its actual use. Linemen can inspect glass insulators from the ground. If the insulator is broken—shattered—it must come down, but if the glass insulator is intact, the lineman knows that it is doing its work just as well as it did the first day it was placed on the cross arm. An additional point is that the building of nests and cocoons under the sides and petticoats of the insulators, impairing the efficiency of operation, is obviated in a glass insulator.

### UNIFORMITY OF MATERIAL

It is essential that insulators be made from a material, the uniformity of which can be maintained over a period of years in order that the quality and performance of insulators manufactured at different times shall not vary. This is essential in order that the user may re-order from time to time the particular type which has best served his needs with the assurance that it will again serve him as well. Glass absolutely fulfills this requirement because it is made from practically unvarying elements standardized by grade and formula and is produced under conditions which do not vary.

### COST

The final requirement of an insulator is, in addition to having the necessary qualities for efficient performance, that it be produced and sold at a figure comparable to the service it gives. On this point, glass again surpasses all other materials not only because of its first cost, but because of its exceptional length of service, its low percentage of replacement, and lastly, because it does not age or deteriorate, requiring total replacement after a comparatively short period of service.



## GLASS INSULATORS—Continued

### IN GENERAL

We have enumerated the pertinent requirements of good insulators. We have shown that, within the range of our experience, glass has more than met them all. We want to emphasize the fact that none of these conclusions are based on theory, but upon severe electrical tests, employing standard methods and conditions, and, further, upon the only real test of any product, *years of satisfactory service*.

In order that this record of achievement be accurate, we circulated a questionnaire to hundreds of users of glass insulators in every part of the United States. This questionnaire brought out many interesting and unexpected facts, chief of which was that many of our insulators were being operated at voltages greatly in excess of our recommended line ratings. As examples, our 10,000 volt insulators were being operated as high as 13,200 volts; our 33,000 volt types at 60,000 volts. Like conditions obtained in many other cases. But, in spite of this fact, over 98 per cent of the replies reported absolutely satisfactory service. Another big majority reported that their replacement item on glass insulators did not exceed 2 per cent per year from all causes. The most important point developed was that not a single case of replacement was due to *aging or deterioration*. The force of this fact becomes impressive when it is realized that this conclusion is based on insulators whose average length of service exceeds twenty years. This point is of particular importance to the user of insulators because it means that, within certain limits, first cost is last cost.

In conclusion:

GLASS is good insulation.

GLASS is easy to inspect.

GLASS is unaffected by time or the elements.

GLASS, because it is manufactured of elements whose chemical components are known and can be controlled, is the same yesterday, today and tomorrow.

and lastly—

GLASS INSULATORS, reasonable in cost, and possessed of the qualities shown above, are the most practical and economical Insulators.

HEMINGRAY GLASS INSULATORS



No. 9



No. 10



No. 12



No. 13

No. 9 PONY



No. 14

Trade No.	DIMENS. Over Height	ALL. DIAM.	INCHES Groove	StL Pkg.	Wt., Lbs. per 1000	Price per 1000
036469	3 <sup>3</sup> / <sub>4</sub>	2 <sup>1</sup> / <sub>4</sub>	3 <sup>3</sup> / <sub>8</sub>	400	675	\$52.00

No. 10 EXCHANGE LINE

83877	3 <sup>1</sup> / <sub>4</sub>	2 <sup>1</sup> / <sub>2</sub>	7 <sup>3</sup> / <sub>16</sub>	350	720	60.00
-------	-------------------------------	-------------------------------	--------------------------------	-----	-----	-------

No. 12 DOUBLE GROOVE PONY



No. 15

036470	3 <sup>5</sup> / <sub>8</sub>	2 <sup>3</sup> / <sub>8</sub>	3 <sup>3</sup> / <sub>8</sub> Top 1 <sup>1</sup> / <sub>4</sub> Bot.	100	750	52.00
--------	-------------------------------	-------------------------------	---	-----	-----	-------

No. 13 NATIONAL PONY (OLD No. 4)

036468	3 <sup>3</sup> / <sub>4</sub>	2 <sup>1</sup> / <sub>2</sub>	3 <sup>3</sup> / <sub>8</sub>	300	825	56.00
--------	-------------------------------	-------------------------------	-------------------------------	-----	-----	-------

No. 14 DEEP GROOVE, DOUBLE PETTICOAT PONY



No. 16

036467	3 <sup>3</sup> / <sub>8</sub>	2 <sup>7</sup> / <sub>8</sub>	3 <sup>3</sup> / <sub>8</sub>	300	865	68.00
--------	-------------------------------	-------------------------------	-------------------------------	-----	-----	-------

No. 15 WESTERN UNION (OLD No. 5)

83878	4 <sup>3</sup> / <sub>8</sub>	2 <sup>3</sup> / <sub>4</sub>	3 <sup>3</sup> / <sub>8</sub>	200	1450	98.00
-------	-------------------------------	-------------------------------	-------------------------------	-----	------	-------

No. 16 LONG DISTANCE



No. 18

036471	4	2 <sup>5</sup> / <sub>8</sub>	3 <sup>3</sup> / <sub>8</sub>	300	970	74.00
--------	---	-------------------------------	-------------------------------	-----	-----	-------

No. 18 DEEP GROOVE

036464	4	2 <sup>7</sup> / <sub>8</sub>	1 <sup>1</sup> / <sub>2</sub>	250	1200	84.00
--------	---	-------------------------------	-------------------------------	-----	------	-------

This page and the following 3 pages are from the McCarthy Bros. & Ford catalog.

1920

(Courtesy of Elton Gish)



HEMINGRAY GLASS INSULATORS



No. 19



No. 20



No. 21



No. 40

No. 19 DEEP GROOVE, DOUBLE PETTICOAT

Line Voltage, 5000

Trade No.	DIMENS. OVER ALL, INCHES	Height	Diam.	Groove	Std. Pkg.	Wt., lbs. per 1000	Price per 1000
036465		3 <sup>7</sup> / <sub>8</sub>	3 <sup>1</sup> / <sub>4</sub>	1 <sup>1</sup> / <sub>2</sub>	200	1350	\$100.00

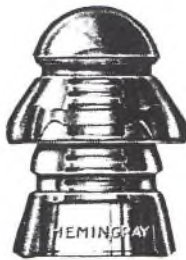

No. 50

No. 20 STREET RAILWAY, OR EXTRA DEEP GROOVE, DOUBLE PETTICOAT

Line Voltage, 5000

036466	4	3 <sup>1</sup> / <sub>4</sub>	3 <sup>3</sup> / <sub>4</sub>		200	1375	100.00
--------	---	-------------------------------	-------------------------------	--	-----	------	--------

No. 21 WESTERN UNION, DOUBLE PETTICOAT

036462	4 <sup>3</sup> / <sub>8</sub>	3 <sup>1</sup> / <sub>4</sub>	3 <sup>1</sup> / <sub>2</sub>		200	1550	104.00
--------	-------------------------------	-------------------------------	-------------------------------	--	-----	------	--------



No. 51

No. 40 DOUBLE PETTICOAT

Line Voltage, 5000

83901	3 <sup>5</sup> / <sub>8</sub>	3 <sup>9</sup> / <sub>8</sub>	5 <sup>1</sup> / <sub>8</sub>		200	1550	108.00
-------	-------------------------------	-------------------------------	-------------------------------	--	-----	------	--------

No. 50 TWO-PIECE TRANSPOSITION

036474	5	3 <sup>1</sup> / <sub>4</sub>	3 <sup>3</sup> / <sub>8</sub> Top 3 <sup>3</sup> / <sub>8</sub> Bot.		125	1950	200.00
--------	---	-------------------------------	---	--	-----	------	--------

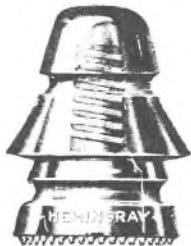

No. 52

No. 51 PERFECT TRANSPOSITION—OLD No. 1

036472	5 <sup>1</sup> / <sub>2</sub>	4 <sup>1</sup> / <sub>4</sub>	3 <sup>3</sup> / <sub>8</sub> Top 1 <sup>1</sup> / <sub>2</sub> Bot.		100	2500	200.00
--------	-------------------------------	-------------------------------	---	--	-----	------	--------

No. 52 TRANSPOSITION—OLD No. 2

036473	4 <sup>3</sup> / <sub>4</sub>	3 <sup>1</sup> / <sub>4</sub>	3 <sup>3</sup> / <sub>8</sub> Top 3 <sup>3</sup> / <sub>8</sub> Bot.		125	2100	148.00
--------	-------------------------------	-------------------------------	---	--	-----	------	--------



No. 53

No. 53 TRANSPOSITION—OLD No. 14

83889	4 <sup>1</sup> / <sub>2</sub>	4	3 <sup>3</sup> / <sub>8</sub> Top 5 <sup>1</sup> / <sub>8</sub> Bot.		100	2250	160.00
-------	-------------------------------	---	---	--	-----	------	--------

HEMINGRAY GLASS INSULATORS



Nos. 60 and 60A



No. 61



No. 62

No. 60 CABLE



No. 63

Trade No.	Height	DIMENS. OVER ALL INCHES		VOLTAGE TEST			Std. Pkg.	Wt., lbs. per 1000	Price per 1000
		Diam.	Groove	Dry	Wet	Line			
036459	5	3 1/4	1 1/2	54500	24000	6600	100	2300	\$140.00

No. 60A CABLE

83903	5	3 1/4	2	54500	24000	6600	100	2300	140.00
-------	---	-------	---	-------	-------	------	-----	------	--------

No. 61 CABLE (OLD No. 1)

83904	3 3/4	3 1/4	1	44200	21800	6600	200	1450	120.00
-------	-------	-------	---	-------	-------	------	-----	------	--------

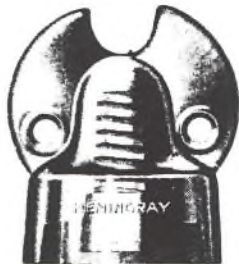

No. 64

No. 62 CABLE (OLD No. 2)

036458	4	3 5/8	1 1/4	56400	25100	6600	125	2100	140.00
--------	---	-------	-------	-------	-------	------	-----	------	--------

No. 63 CABLE (OLD No. 3)

83905	5 7/8	4 1/4	2	60200	28300	7500	65	3600	220.00
-------	-------	-------	---	-------	-------	------	----	------	--------

No. 64 COLUMBIA DOUBLE PETTICOAT



No. 70

036460	5 1/4	4	1 1/4	62400	29500	6600	100	2800	200.00
--------	-------	---	-------	-------	-------	------	-----	------	--------

No. 70 HIGH POTENTIAL TRIPLE PETTICOAT CABLE

83906	5	4 3/4	1 3/4	61900	37800	10000	65	3150	225.00
-------	---	-------	-------	-------	-------	-------	----	------	--------



HEMINGRAY GLASS INSULATORS



No. 71



No. 72



No. 73

No. 71 HIGH VOLTAGE (OLD No. 1)

Trade No.	VOLTAGE TEST			Std. Pkg.	Wt. Lbs. per 1000	Price per 1000
	Dry	Wet	Line			
036454	58400	31000	10000	100	2500	\$165.00

Dimensions, inches: Height,  $3\frac{3}{4}$ ; diameter,  $4\frac{3}{4}$ ; groove,  $\frac{5}{8}$ .

No. 72 HIGH VOLTAGE (OLD No. 4)

83917	64000	31400	10000	100	2700	165.00
-------	-------	-------	-------	-----	------	--------

Dimensions, inches: Height, 4; diameter,  $4\frac{3}{4}$ ; top groove, 1 inch; side groove,  $\frac{3}{4}$ .



No. 74

No. 73 PROVO TYPE (OLD No. 2)

036455	74400	43800	15000	60	3600	300.00
--------	-------	-------	-------	----	------	--------

Dimensions, inches: Height,  $4\frac{3}{4}$ ; diameter,  $5\frac{1}{2}$ ; top groove,  $\frac{3}{4}$ ; bottom groove,  $\frac{1}{2}$ .

No. 74 PROVO TYPE (OLD No. 1)

036453	93700	55200	19000	25	7000	450.00
--------	-------	-------	-------	----	------	--------

Dimensions, inches: Height, 6; diameter, 7; top groove,  $\frac{5}{8}$ ; center groove,  $\frac{3}{8}$ ; bottom groove,  $\frac{1}{2}$ .

Made for standard 1-inch and special  $1\frac{3}{8}$ -inch pins.



Nos. 75 and 76

No. 75 (7-INCH) MUNCIE TYPE

036452	86200	50100	17000	30	6200	450.00
--------	-------	-------	-------	----	------	--------

Dimensions, inches: Height,  $4\frac{7}{8}$ ; diameter, 7; groove,  $\frac{7}{8}$ .

Made for standard 1-inch and special  $1\frac{3}{8}$ -inch pins.

No. 76 (9-INCH) MUNCIE TYPE

83918	95000	80000	22000	16	11250	750.00
-------	-------	-------	-------	----	-------	--------

Dimensions, inches: Height,  $5\frac{7}{8}$ ; diameter, 9; groove,  $\frac{7}{8}$ .

No. 77 (9-INCH) MUNCIE SLEEVE

83919	.....	.....	.....	32	5400	525.00
-------	-------	-------	-------	----	------	--------

Dimensions, inches: Height, 8; diameter,  $5\frac{1}{2}$ .

No. 78 (9-INCH) MUNCIE TYPE ASSEMBLED

83920	110000	95000	33000	8	18125	1275.00
-------	--------	-------	-------	---	-------	---------

Dimensions, inches: Height,  $13\frac{7}{8}$ ; diameter, 9; groove,  $\frac{7}{8}$ .



No. 78 Insulator with No. 77 Sleeve

TRADE MARK  
**STANDARD HEMINGRAY INSULATORS**  
 REGISTERED.

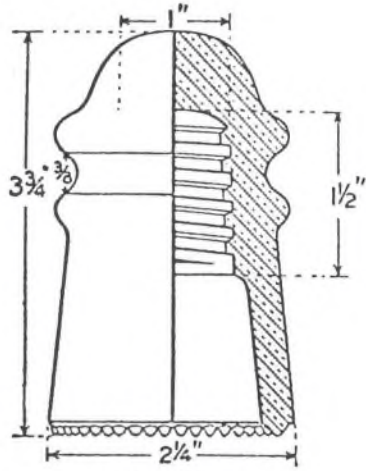

No. 9 Pony

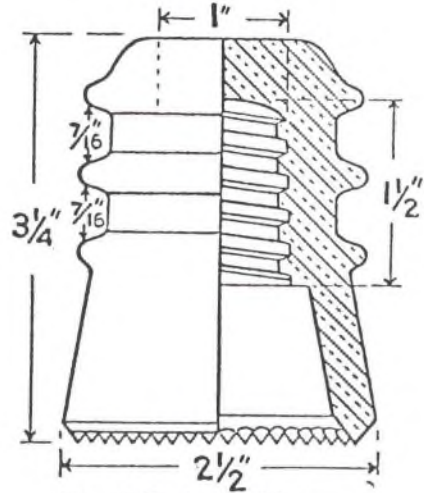

No. 10 Exchange Line

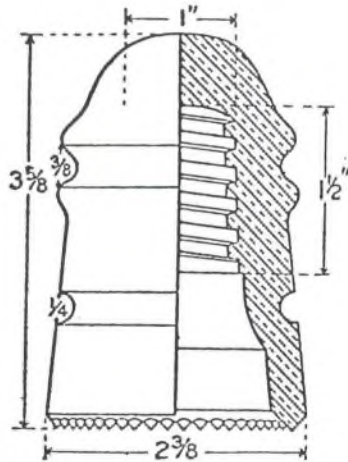

No. 12 Double Groove Pony

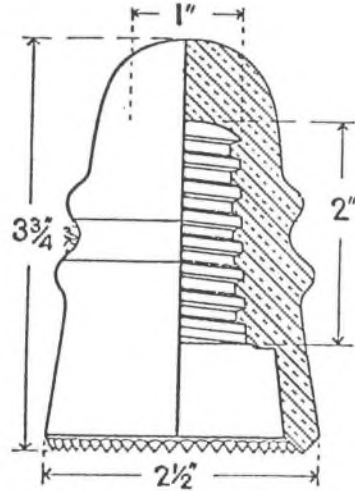

No. 13 National Pony

Mfr. No.	Description	Diameter Groove	Weight Each	Weight Per 1000 Packed	Standard Package Quantity
9	Pony.....	3/8 in.	9 ozs.	695 lbs.	400
10	Exchange Line.....	7/16 in.	10 ozs.	765 lbs.	350
12	Double Groove Pony.....	3/8 in.	10 1/2 ozs.	790 lbs.	400
13	National Pony.....	3/8 in.	11 ozs.	820 lbs.	300

Page 17

Page from a Hemingray catalog.  
 Bulletin No. 1  
 15 May 1921  
 (Courtesy of Mike Sovereign and Glenn Drummond)



GLASS INSULATORS

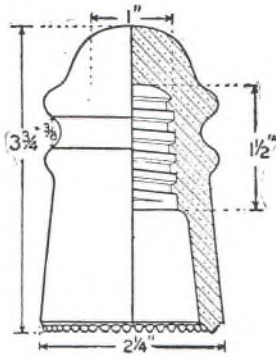

No. 9

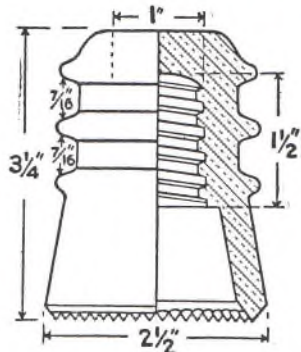

No. 10

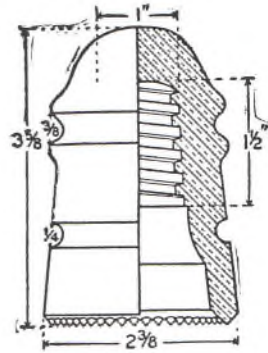

No. 12

GLASS INSULATORS

List No.	Description	Std. Pkg. Quantity	Wt. per 1000 Packed	W. E. List Price, Each
9	Pony	400	695 lbs.	\$0.19
10	Ex. Line	350	765 lbs.	.19
12	D.C. Pony	400	790 lbs.	.19

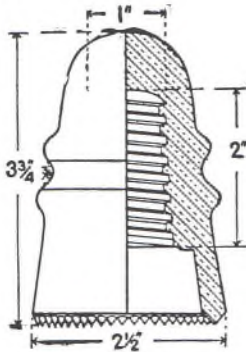

No. 13

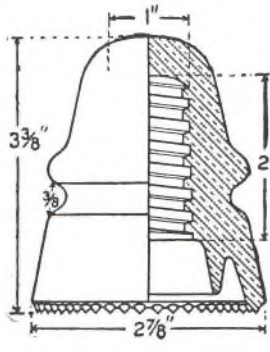

No. 14

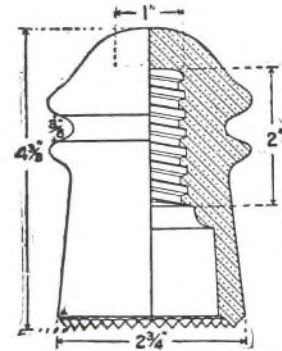

No. 15

List No.	Description	Std. Pkg. Quantity	Wt. per 1000 Packed	W. E. List Price, Each
13	N. Pony	300	820 lbs.	\$0.20
14	D.G.D.P. Pony	300	870 lbs.	.22
15	Western Union	200	1450 lbs.	.28

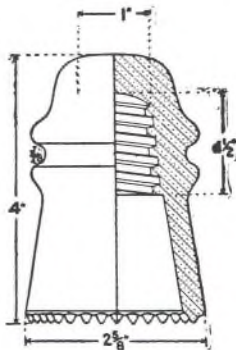

No. 16

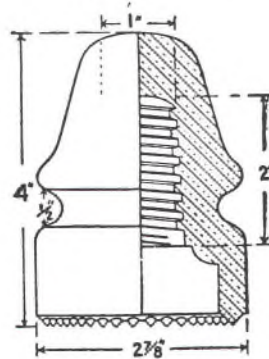

No. 18

List No.	Description	Std. Pkg. Quantity	Wt. per 1000 Packed	W. E. List Price, Each
16	Long Distance	300	1000 lbs.	\$0.23
18	Deep Groove	250	1200 lbs.	.28

Delivery F. O. B. Muncie, Ind. For warehouse deliveries write nearest house.

This page and the following 2 pages are from  
the Western Electric catalog.

1922

(Courtesy of Elton Gish)

Western Electric  
GLASS INSULATORS

Mail Orders Filled  
at Prevailing Prices

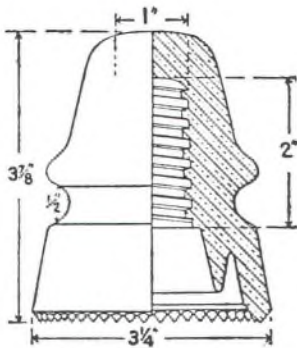

No. 19

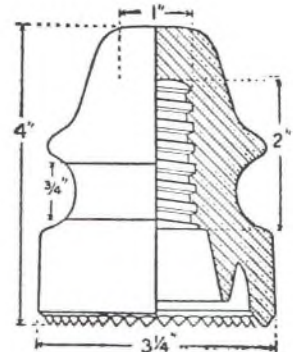

No. 20

List No.	Description	Diam. Groove	Weight Each	Wt. per 1000 Packed	Std. Pkg. Quantity	W.E. List Price Each
*19	Deep Groove, Double Petticoat.....	1/2 in.	19 ozs.	1350 lbs.	200	\$0.29
20	Street Railway or Extra Deep Groove, Double Petticoat.....	3/4 in.	20 ozs.	1375 lbs.	200	.29

\* Also made in Amber, Blue, and Crystal Colors.

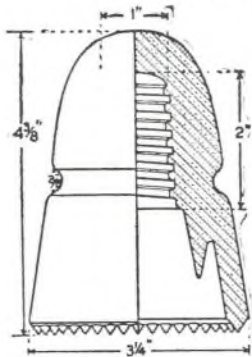

No. 21

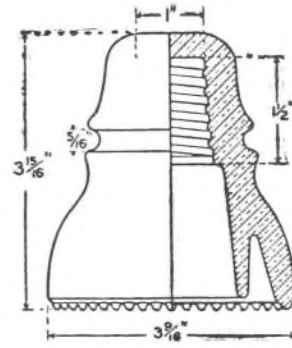

No. 40

21	Standard W. U. Double Petticoat.....	3/8 in.	22 ozs.	1550 lbs.	200	\$0.32
40	Double Petticoat, new W. U. Standard..	1/16 in.	22 ozs.	1550 lbs.	200	.32

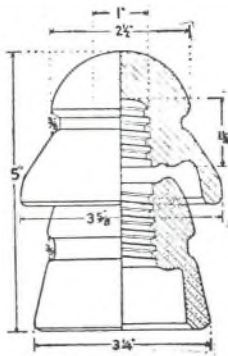

No. 50

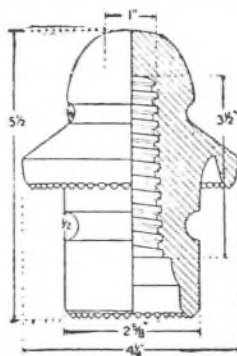

No. 51  
(Old No. 1)

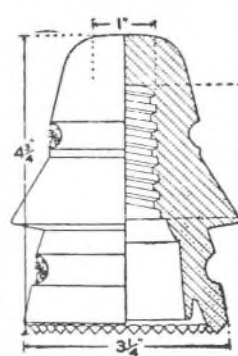

No. 52  
(Old No. 2)

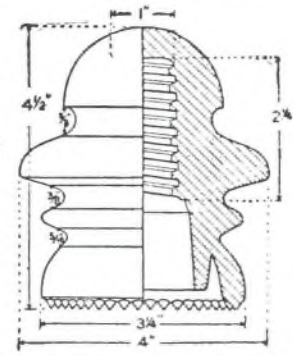

No. 53  
(Old Locke No. 14)

50	Two-piece Transposition.....	3/8 in.	25 ozs.	1950 lbs.	125	\$0.60
51	Perfect Transposition.....	3/8 in.	34 ozs.	2500 lbs.	100	.60
52	Transposition.....	3/8 in.	28 ozs.	2100 lbs.	125	.44
53	Transposition.....	3/8 in.	30 ozs.	2250 lbs.	100	\$0.49

Delivery F. O. B. Muncie, Ind. For warehouse deliveries write nearest house.  
Weights given are approximate.



GLASS INSULATORS

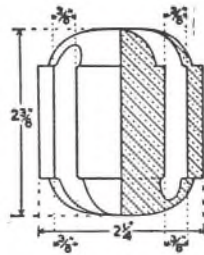

No. 90

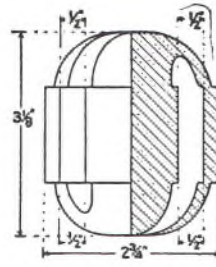

No. 91

SPAN WIRE INSULATORS

List No.	Description	Crushing Strength	Diam. Groove	Weight Each	Wt. per 1000 Packed	Std. Pkg. Quantity	W. E. List Price Each
90	Span wire (Old No 10).....	4912 lbs.	3/8 in.	17 o.s.	720 lbs.	500	\$0.64
91	Span wire (Old No 15).....	5910 lbs.	1/2 in.	11 1/2 ozs.	1260 lbs.	250	.96

GLASS KNOBS AND MINE INSULATOR

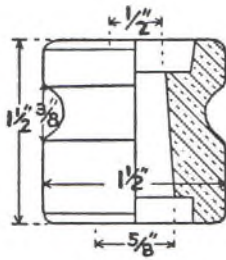

No. 100

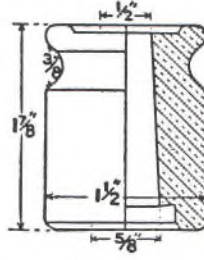

No. 101

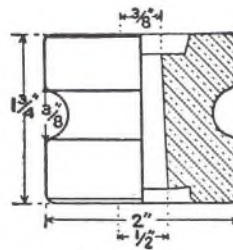

No. 102

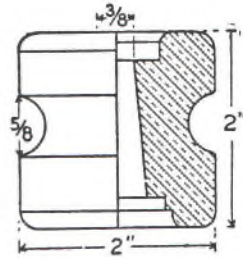

No. 103

List No.	Description	Diam. Groove	Weight Each	Wt. per 1000 Packed	Std. Pkg. Quantity	W. E. List Price Each
100	Knob (Old No. 1).....	3/8 in.	3 ozs.	200 lbs.	500	\$0.17
101	Knob (Old No. 1 1/2).....	3/8 in.	3 1/2 ozs.	230 lbs.	500	.19
102	Knob (Old No. 2).....	3/8 in.	6 1/2 ozs.	440 lbs.	500	.21
103	Knob (Old No. 3).....	5/8 in.	7 ozs.	460 lbs.	500	.21

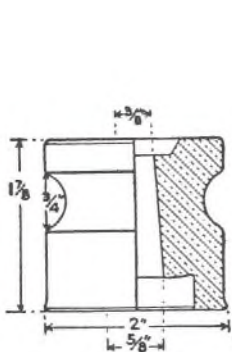

No. 107

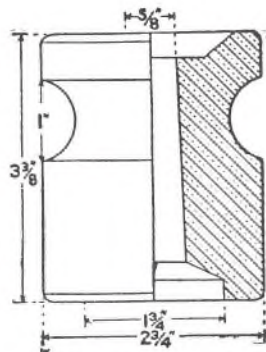

No. 108

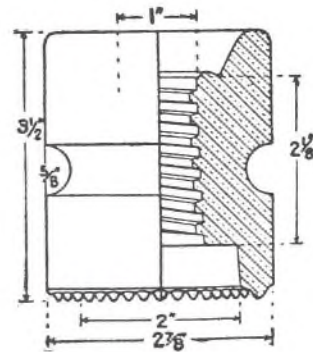

No. 95

107	Knob (Old No. 7).....	3/4 in.	7 ozs.	460 lbs.	500	\$0.21
108	Knob (Old No. 8).....	1 in.	21 1/2 ozs.	1500 lbs.	200	.67
95	Mine insulator (Old No. 1).....	5/8 in.	20 ozs.	1475 lbs.	200	.58

Delivery F. O. B. Muncie, Ind. For warehouse deliveries write nearest house.

**JOSLYN MANUFACTURING & SUPPLY COMPANY**

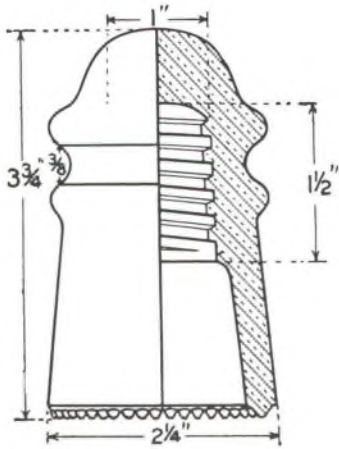

No. H9 Pony

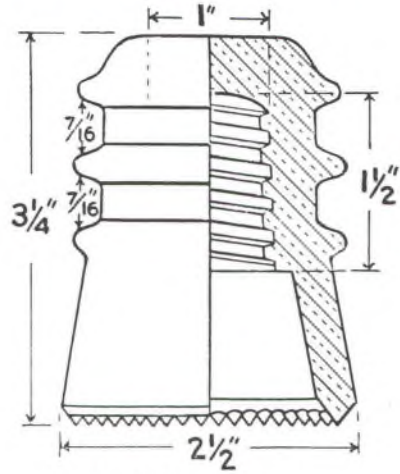

No. H10 Exchange Line

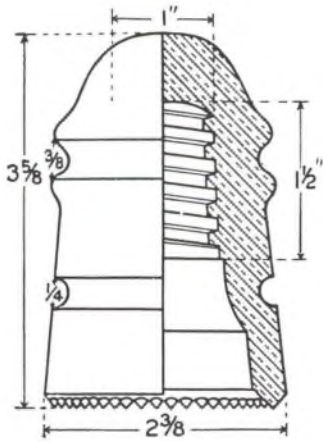

No. H12 Double Groove Pony

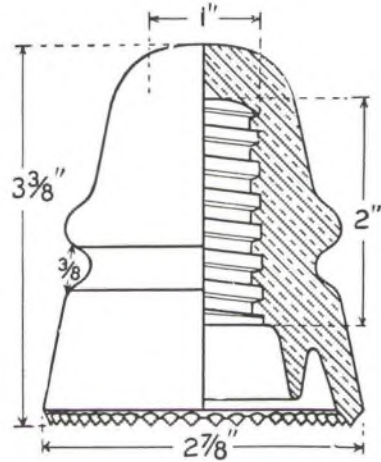

No. H14

Stock No.	Description	Diameter Groove, In.	Weight Per 1000 Packed, Lbs.	Standard Package
H 9	Pony.....	3/8	648	250
H10	Exchange Line.....	7/16	704	250
H12	Double Groove Pony.....	3/8	752	250
H14	Deep Groove, Double Petticoat Pony.....	3/8	820	200

This page and the following 7 pages are from  
 the Joslyn Manufacturing & Supply Co. catalog.  
 1934  
 (Courtesy of Elton Gish)



# JOSLYN MANUFACTURING & SUPPLY COMPANY

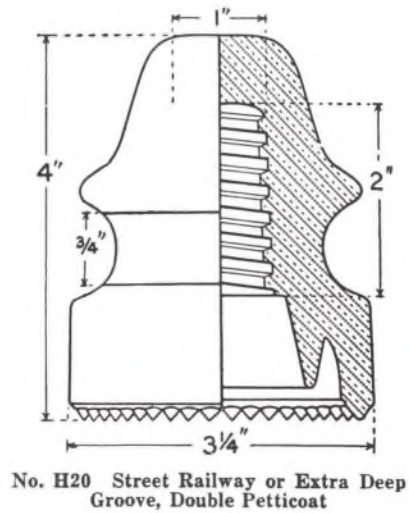
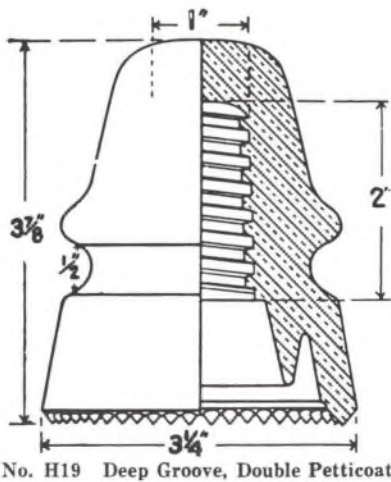
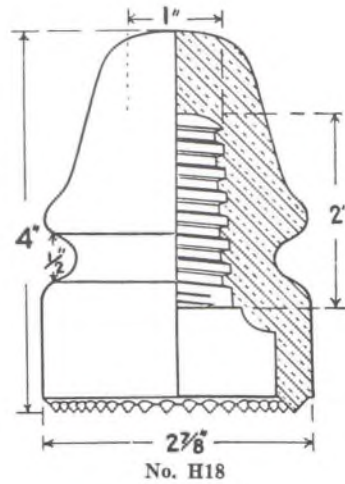
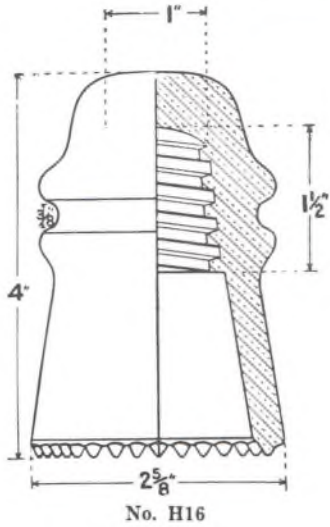

Stock No.	Description	Leakage Distance, In.	Wet Arcing Distance, In.	Wt. Per 1000 Packed, Lbs.	Std. Package Quantity
H16	Long Distance.....	...	-	1057	175
H18	Deep Groove.....	...	-	1246	175
H19	Deep Groove, Double Petticoat.....	4 1/8	1	1241	150
H20	Street Ry. or Ex. Deep Grv. Double Petticoat.....	4 3/8	1	1241	150

# JOSLYN MANUFACTURING & SUPPLY COMPANY

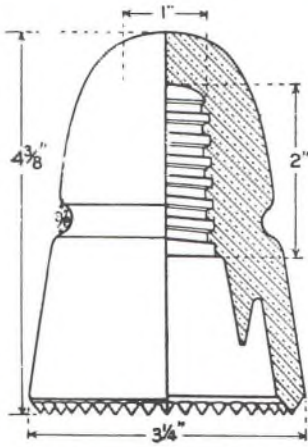

No. H21 Western Union,  
Double Petticoat

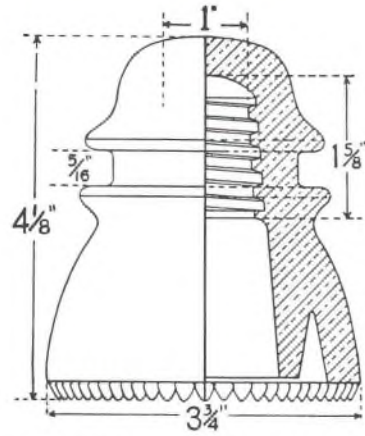

No. H42 Double Petticoat, 24 Oz.

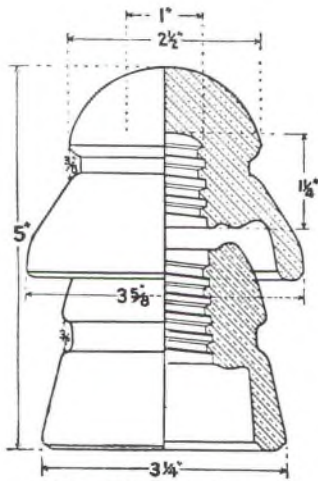

No. H50 Two-Piece  
Transposition

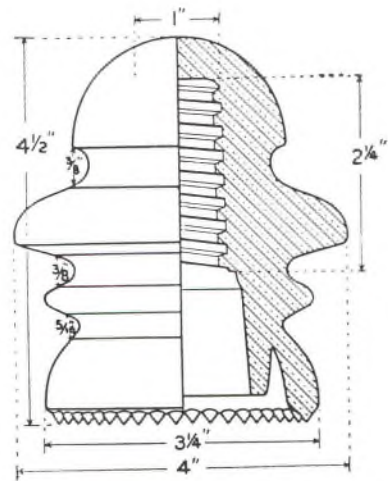

No. H53 Transposition

Stock No.	Description	Diameter Groove, In.	Weight Per 1000 Packed, Lbs.	Standard Pkg. Quantity
H21	Western Union (Old Style).....	3/8	1410	100
H42	Double Petticoat, 24 Oz.....	5/16	1690	100
H50	Two-Piece Transposition.....	3/8	1880	75
H53	Transposition.....	3/8	2200	50



# JOSLYN MANUFACTURING & SUPPLY COMPANY

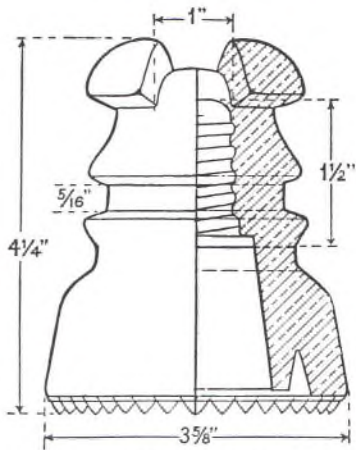

No. H43 Top Groove Western Union

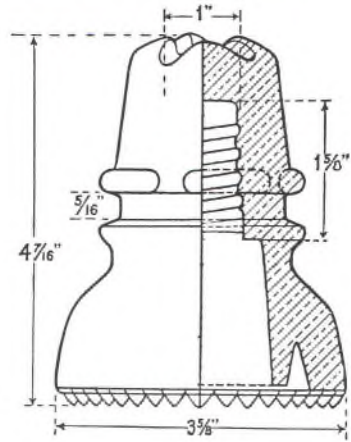

No. H44 Top Groove, Telephone

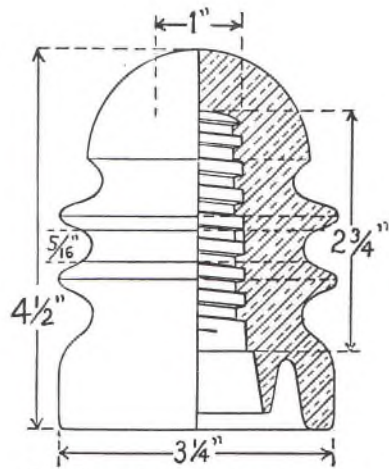

No. H55 One-Piece Transposition

Stock No.	DIA. GROOVE	Packed Wght. per M Pcs.	Standard Package
H43	5/16	1990	100
H44	5/16	1720	75
H55	5/16	2080	50

# JOSLYN MANUFACTURING & SUPPLY COMPANY

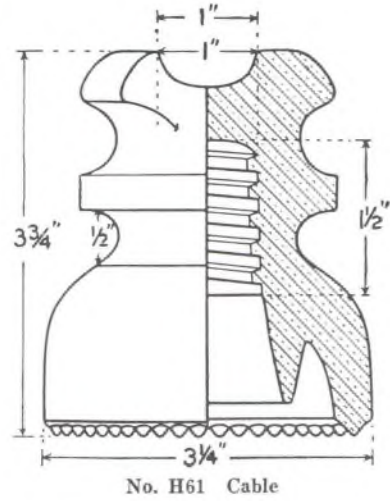
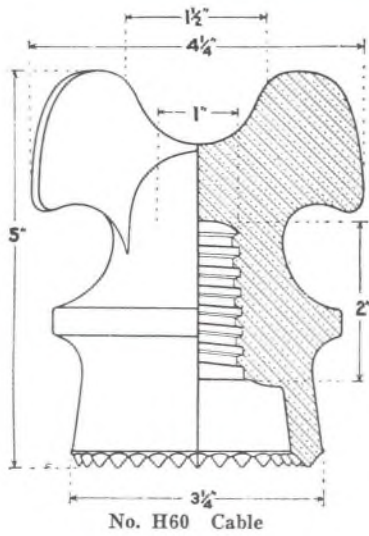

Stock No.	Description	Diameter Groove, In.	Weight Per 1000 Packed, Lbs.	Standard Pkg. Quantity
H60	Cable.....	1 1/2	2300	50
H60A	Cable—same design as No. 60.....	2	2240	50
H61	Cable.....	1	1261	150

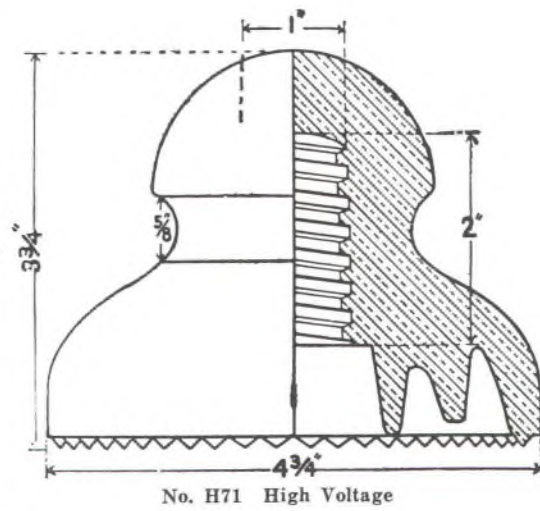
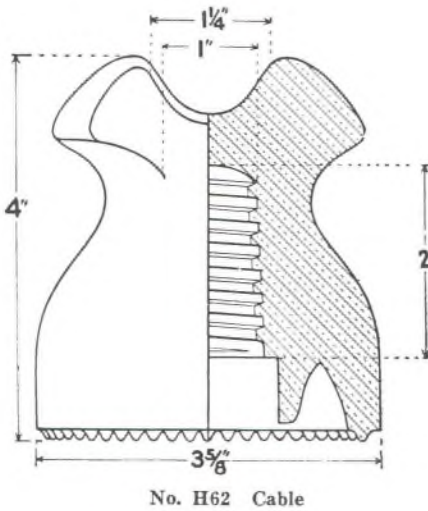

Stock No.	Description	Voltages			Leakage Distance In.	Wet Arcing Distance In.	Weight Per 1000 Pkd. Lbs.	Standard Package Quantity
		Line	Dry Test	Wet Test				
H62	Cable.....	6600	49600	29100	5 3/8	1 1/2	1720	100
H71	High Voltage ..	10000	48700	31700	7	1 3/4	2440	50



# JOSLYN MANUFACTURING & SUPPLY COMPANY

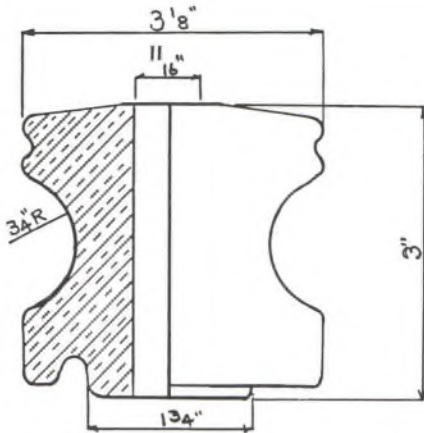

No. HD518 Secondary Rack Insulator

Height ..... 3 in.  
 Diameter ..... 3 1/8 in.  
 Hole ..... 1 1/8 in.  
 Groove ..... 1 1/2 in.  
 Weight per Piece..... 21 oz.  
 Packed in Boxes of..... 50  
 Weight per Box..... 66 lbs.  
 Weight per 1000 packed..... 1320 lbs.

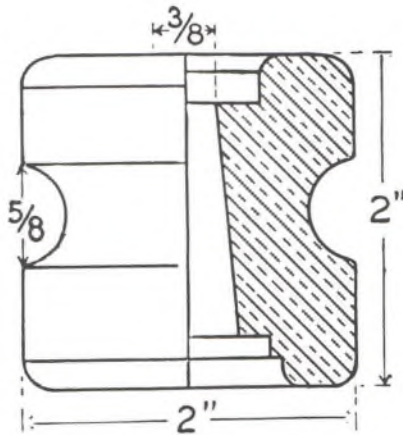

No. H103 Knob

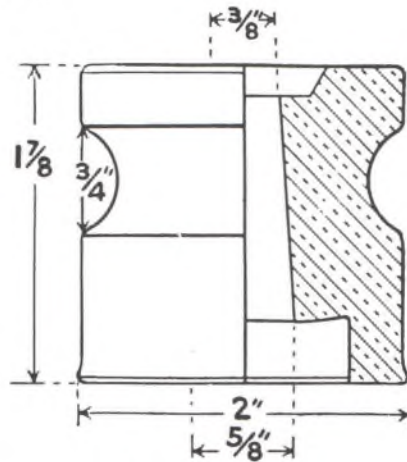

No. H107 Knob

Mfr. No.	Description	Diameter Groove, In.	Weight Per 1000 Packed, Lbs.	Standard Pkge. Quantity
<b>H103</b>	Knob .....	3/8	480	250
<b>H107</b>	Knob .....	3/4	456	250

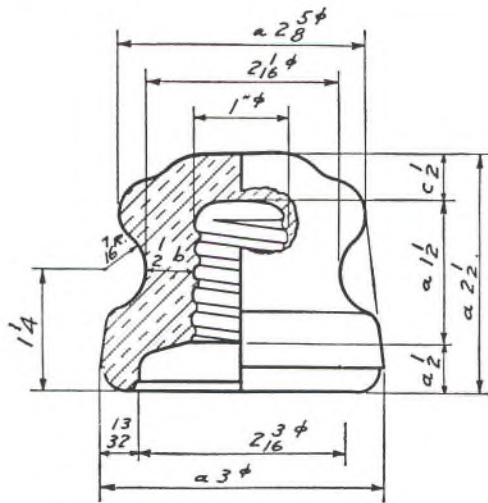

No. HD990 For Secondary Circuits and Low Voltage Lines

The glass insulators illustrated in this page are especially adapted for Distribution Lines. These insulators are Heat Shock Tested at the factory by a more severe change than ever could be experienced in any possible weather condition. This test obviates any possibility of breakage from weather conditions.

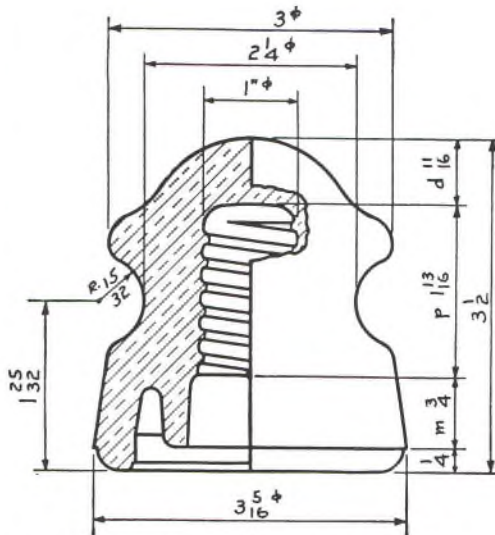

No. HD510 For 2300 V, 4600 and 4000 V Primary Circuits

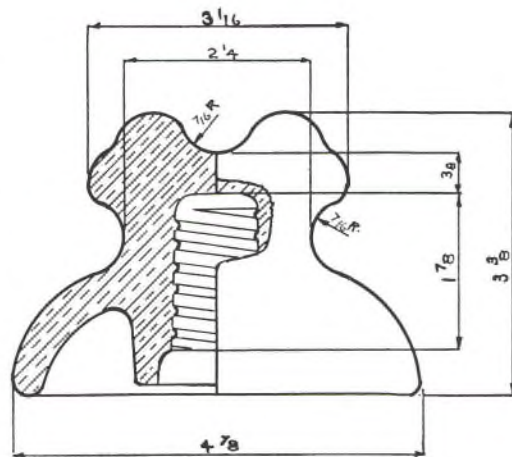

No. HD512 For 2300 V, 4600 and 4000 V Primary Circuits

Stock Number	Line Voltage	Dry Flashover	Wet Flashover	Dia. Groove In.	Packed Weight per M Pcs.	Standard Package
HD990	.....	35000V	10000V	3/4	940	50
HD510	6600	36900V	21400V	5/8	1280	50
HD512	6600	50300V	26300V	3/4	1580	50



# JOSLYN MANUFACTURING & SUPPLY COMPANY

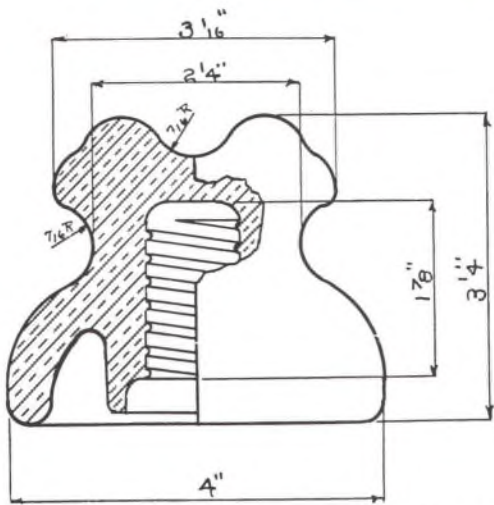

No. HD513 For Primary Power Distribution Circuits  
6900 to 8000 Volts

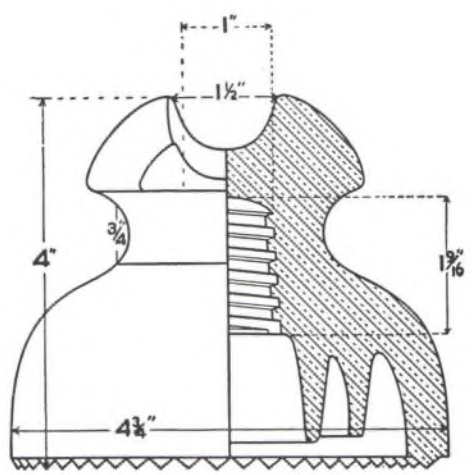

No. HD72 For Primary Power Distribution Circuits  
6900 to 10,000 Volts

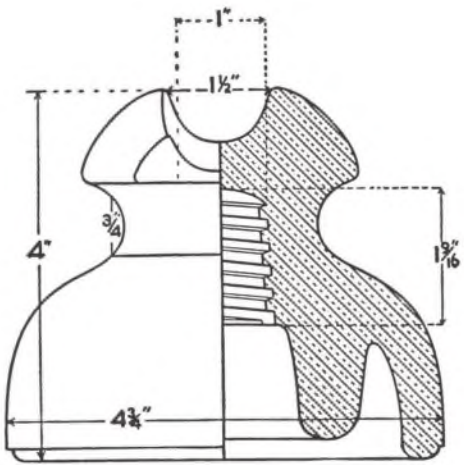

No. HD720

Stock No.	Line Voltage	Dry Flashover	Wet Flashover	Dia. Groove, In.	Packed Wght. per M Pcs.	Standard Package
<b>HD513</b>	11000V	53100V	32300V	7/8	1970	30
<b>HD72</b>	10000V	62800V	35200V	7/8	2740	50
<b>HD720</b>	13500V	62800V	35200V	7/8	2580	50



# LOWEX

Tr. & Mark.  
Reg. U.S. Pat. Off.

*(Low Expansion—Low Expense)*

## POWER DISTRIBUTION INSULATORS

by Owens-Illinois Glass Company

HEMINGRAY DIVISION

MUNCIE, INDIANA

This page and the following 7 pages are from  
a LOWEX advertising brochure.

1940

(Courtesy of Mr. N. R. Woodward)



# LOWEX

## DESCRIPTION AND QUALITIES RESEARCH AND DEVELOPMENT

LOWEX, the result of exhaustive research by the Hemingray Division of the Owens-Illinois Glass Company, is a material that has a consistency of composition that when made up into high voltage insulators produces a homogeneous product which will stand the dielectric and mechanical stresses to a degree not obtained by other similar materials. The principle qualities responsible for this behavior are as follows:

**LOW EXPANSION** insures high thermal endurance. This means that Lowex has particularly high resistance to shocks such as those an insulator is subject to by sustained flashover.

**DIELECTRIC BREAK-DOWN.** Lowex not only has a strong resistance to puncture but it is very consistent in its behavior in that the homogeneity of this material obviates the possibility of puncture.

**LOW DIELECTRIC CONSTANT** reduces the noise level in the case of radio interference and decreases the losses in insulators carrying high frequency.

**HIGH MECHANICAL STRENGTH.** The strength of Lowex has been determined by comparative tests of the finished insulators. These tests show a high and consistent value due mainly to the simple formula of the material and the ease with which this glass can be formed into shape. For this reason the completed insulator is free from the defects that so reduce the strength of other ceramic materials.

**HARD SURFACE.** The hard, resistant surface of Lowex means that it will resist the action of the elements, will not become rough nor have a tendency to hold dirt. In locations where dirt accumulates rapidly on insulators the necessity of cleaning will be reduced to a minimum.

**DESIGN.** The design of Lowex insulators is in accordance with the best electrical engineering practice. The design of the threaded pin cavity is such that maximum strength is attained on standard wood and lead thread pins. As the shape of the pin deviates from standard the maximum strength of the insulator necessarily is lowered.

### RESEARCH AND DEVELOPMENT

There are some specific qualities that a material must have to be suitable for electrical insulating purposes. Electrically, it must have high dielectric strength and low dielectric constant. Physically, it should have a low

thermal expansion, high mechanical strength, and a hard surface.

Throughout its 66 years in the insulator business, the Hemingray name has been constantly associated with research development and improvement of the materials, design and manufacture of insulators. As a result of this exhaustive work, materials were developed in 1937 which produced a greatly improved insulator but at considerably increased cost. Nonetheless, a great number of pieces were made and tested and excellent results were obtained.

In the spring of 1938, it was decided to try a mixture of materials which it was feared would not mechanically form a workable glass. A furnace was charged with this material and with slight alterations it was found to give excellent working conditions. A considerable quantity of the material was furnished for experimental use, and under test showed very good results. A small operation was then started with this glass for power insulators and at the solicitation of a large utility company 30 pound, 25KV transformer bushings were produced for test purposes. These pieces performed so well in their tests that the utility company engineers immediately came to the factory to observe the process of manufacture and to draw up specifications for Owens-Illinois Glass Co. to furnish this material.

A quantity of brown pin type insulators were made and submitted to a large operating group for test. This material worked out so favorably with them, that at the present time they are using it exclusively for their distribution insulators. Thus it was that in January, 1939, we had developed a material which, when all of the factors were taken into consideration, was superior to anything else on the market for insulating purposes.

All of our insulators are made up and periodically tested under the standard specifications of the AIEE and the ASTM and we are in a position to furnish an authentic history on all products leaving our factory.

Quality control is a very essential factor in producing a consistent product and periodical analysis of our product to determine whether it is up to the standard quality is a routine procedure in our plant.

We are now having extensive tests made at various testing laboratories as a further check and to give us additional authentic test reports on the various types of insulators we are now producing.

Other agencies doing research and testing on these insulators include: Purdue University, Lafayette, Indiana; Toledo Laboratory of Owens-Illinois Glass Company; Hemingray Laboratory, Muncie, Indiana.

# LOWEX

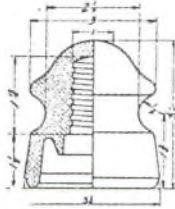

No. 510

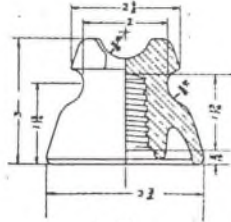

No. 511

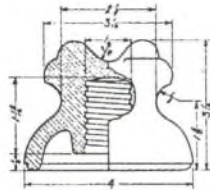

No. 512

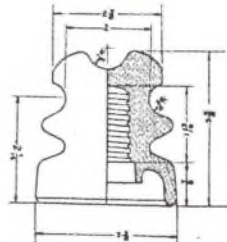

No. 660

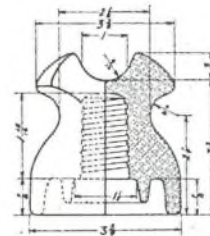

No. 62

INSULATOR NUMBER	510	511	512	660	62
Dry 60 Cycle Flashover	35	50	50	55	50
Wet 60 Cycle Flashover	20	25	25	35	30
Critical Impulse Flashover	75	85	85	85	85
Leakage Distance	4"	4 3/8"	4"	5 1/8"	5 1/2"
Dry Arcing Distance	2 3/8"	3 1/8"	3"	3 1/2"	3 1/2"
Wet Arcing Distance	1"	1 1/4"	1 1/4"	1"	1 1/8"
Approximate Mechanical Strength	4000	3000	3000	2500	3000
Minimum Pin Height	4"	4"	4"	4"	4"
Number Insulators per Carton	50	50	50	50	40
Weight per Carton	60 1/2	59	63	64	70
Weight per 100	121	118	126	128	175



# LOWEX

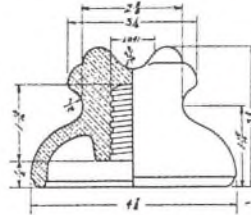

No. 513

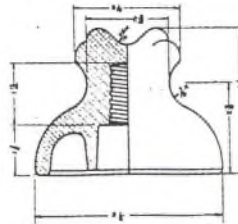

No. 514

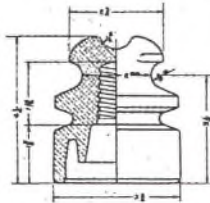

No. 670

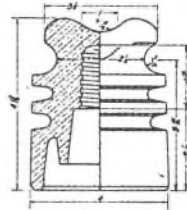

No. 680

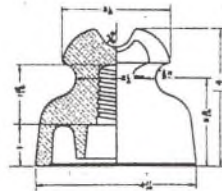

No. 720

INSULATOR NUMBER	513	514	670	680	720
Dry 60 Cycle Flashover	60	70	65	70	65
Wet 60 Cycle Flashover	35	40	40	45	35
Critical Impulse Flashover	95	120	100	120	95
Leakage Distance	5"	8"	7 1/2"	9 1/2"	7 1/2"
Dry Arcing Distance	4"	4 3/8"	4 1/2"	5"	4 1/2"
Wet Arcing Distance	1 3/4"	2"	1 1/8"	1 1/4"	1 3/4"
Approximate Mechanical Strength	2500	3000	2500	3000	3000
Minimum Pin Height	5"	5"	5"	5 1/2"	5"
Number Insulators per Carton	30	18	24	24	50
Weight per Carton	59 1/2	53 1/2	49	70	137
Weight per 100	198	297	208	297	274

# LOWEX

## RADIO INTERFERENCE INSULATORS

● Radio interference insulators are coated around the wire groove and in the pin hole with a permanent coating applied to the insulator when it is in a molten condition. This method of application fuses the coating so that it becomes a part of the glass and is not subjected to deterioration during the life of the insulator.

Its conducting qualities are such that there tends to be a reduction of the corona at the edge of the coating which materially assists in giving the insulator a very high radio interference value resulting in a permanent installation in which the low radio interference characteristics are maintained indefinitely.

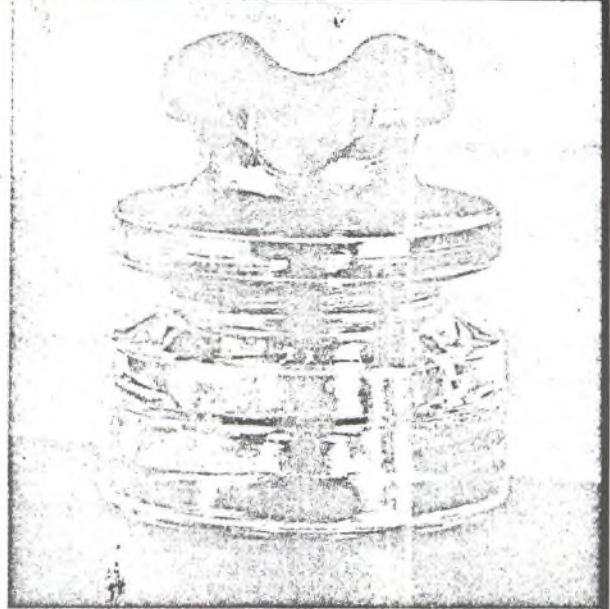

## SECONDARY RACK SPOOL INSULATORS

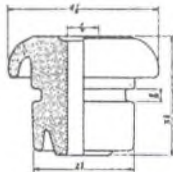

No. 109

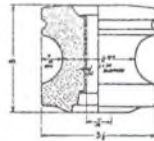

No. 518LB

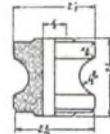

No. 519



● The 518LB spools are furnished with a 1/16" thick lead bushing. This lead bushing materially increases the mechanical strength of the spool and prevents injury of the inside surface from the roughness of the bolt on which the spool is assembled.

The homogeneous material from which the spool is made provides extremely long life without crazing or other surface defects, which would tend to reduce its mechanical strength.

TYPE OF INSULATORS	518LB	519	109
Dry Flashover	20,000	13,600	
Wet Flashover	10,000	7,000	
Diameter	3 1/8"	2 1/4"	4 1/8" Top 2 3/4" Bottom
Height	3"	2 1/4"	3 1/4"
Wire Groove Diameter	1 11/32"	1"	1 11/32"
Mechanical Strength	4000	3000	4000
Shipping Weight per M.	1450	559	1900
Pieces per Standard Package	50	75	40
Weight per Standard Package	72 1/2	42	76



# SPECIALTY ITEMS

● Many types of Lowex specialty items are produced by the Hemingray Division of Owens-Illinois Glass Company. This division is equipped to manufacture almost any type of pressed glass electrical accessories. For further information write Owens-Illinois Glass Company, Hemingray Division, Muncie, Indiana, enclosing if possible a sketch of the proposed specialty. Prices and complete information will be returned immediately.

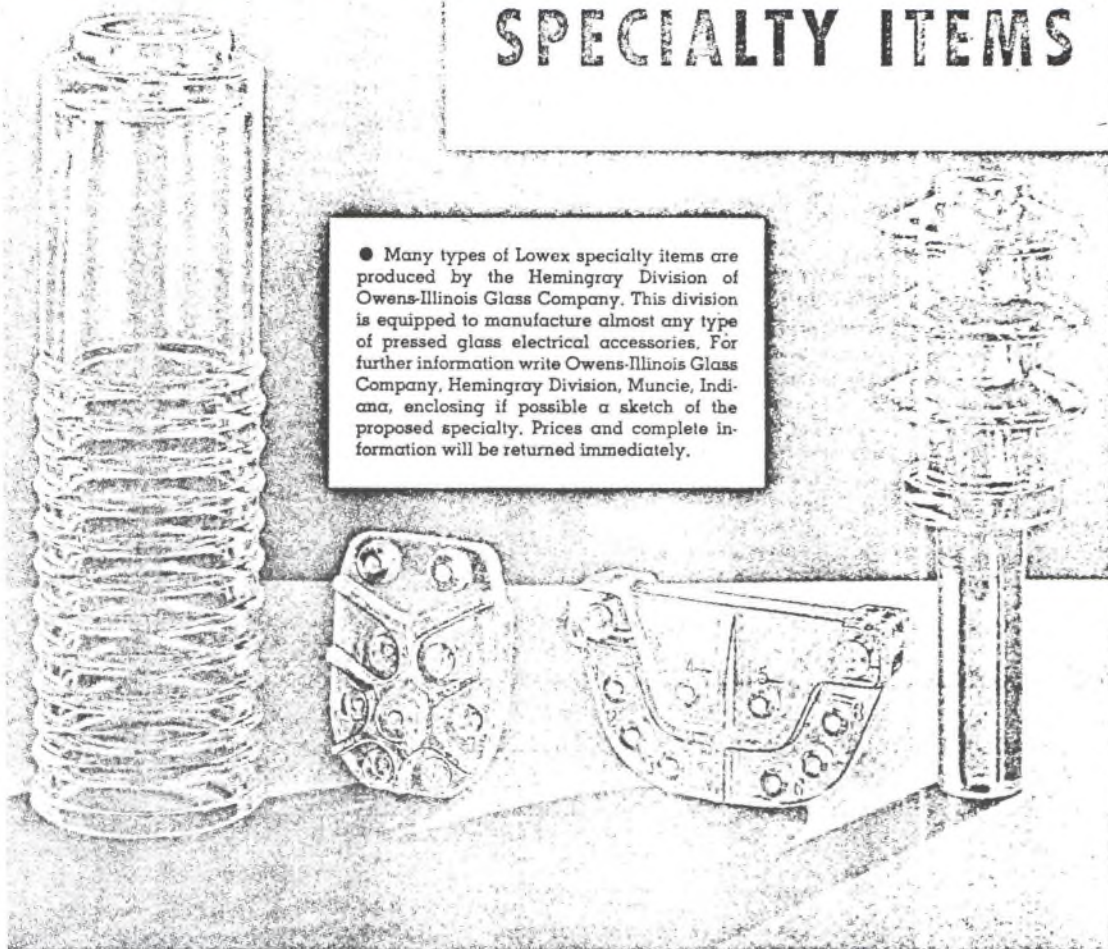

COMPARATIVE CATALOG NUMBERS—PRIMARY DISTRIBUTION INSULATORS													
LOWEX No.	Approximate Operating Voltage	Old Trade Voltage Rating	E E I Class	Knox	Lopp	Locke	O-S	Pinco	Porcelain Products	Thomas	Victor	Illinois	Westing-house
510	2300/4000Y	6600	1	237	591A	44	29207	62	6180	1111	4	237	104
511	4600	7500	2	247	6192	2	9404	223	6194	1205	2	247	136
512	4600	7500	2	253	6188	8881	12847	401	6188	1009	8	253	146
660	4600	7500	2			66	34847		6366	266	16	69	968472
62	4600	7500	2	256	6086	3749	9953	264	6145	1108	3	256	106
513	6600/11400Y	13500	3	261	6186	9995	12848	63	6195	1177	5	261	166
514	13200	17500	4	266	7385	10270	29732	1044	6197	1216	11	266	1012
670	6600/11400Y		3		77		34848		6377	277	17	135	968473
680	13200		4		88		34849		6388	288	18	175	968474
720	6600/11400	13500	3	261	6186	9995	29732	1044	6197	1216	11	266	166

# LINE CONSTRUCTION

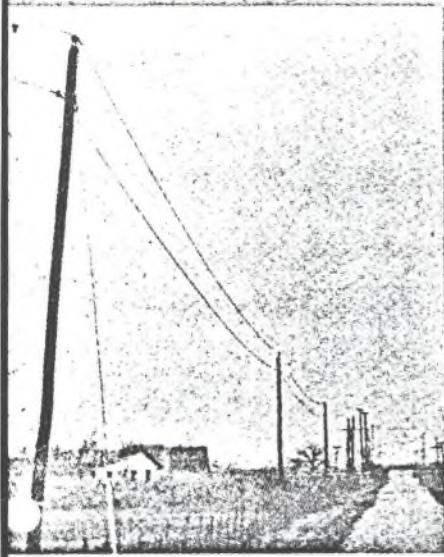

25 KV line on glass insulators in service since 1899. →

← 6.9 KV line on No. 660 insulators treated for radio interference.

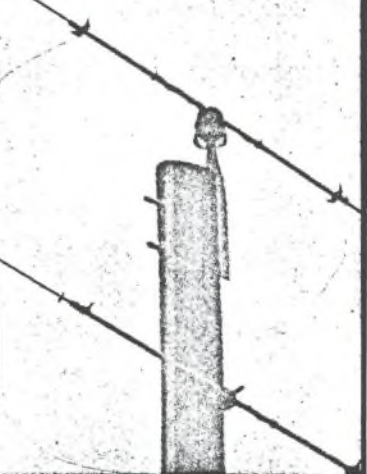
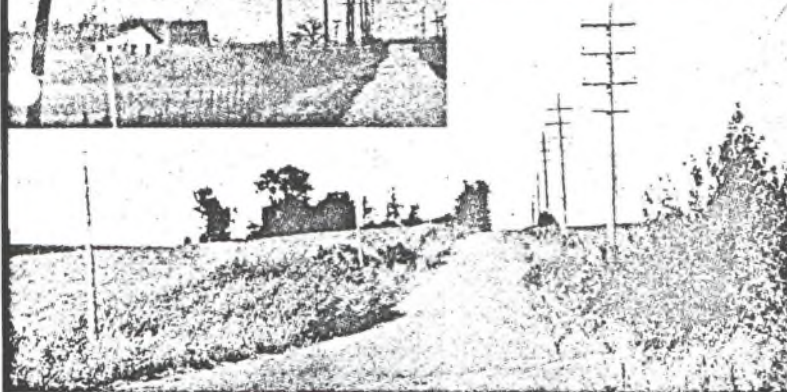
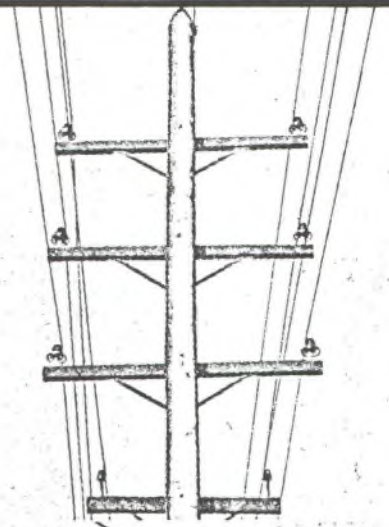

## ACCEPTANCE OF LOWEX INSULATORS

● These modern Lowex glass insulators are the result of a long specialized experience backed by extensive research and exhaustive testing. Their immediate acceptance by a number of leading public utilities offers further proof of their excellent performance. Lowex insulators are the practical common-sense insulators to buy for distribution line service. They are efficient — never age —

and cost less to buy and to own. Improved manufacturing methods, constant tests, and production inspection insure continuous quality and a thoroughly satisfactory product. If you aren't using the new Lowex insulators on your distribution lines, order today from your jobber or write for samples and prices.



# LOWEX

● It is interesting to note that the development of Lowex insulators comes from one of the oldest manufacturers of insulators in the industry . . . The Hemingray Glass Company was established in 1848, incorporated in 1870 and has manufactured insulators continuously since 1863 . . . It was acquired by the Owens-Illinois Glass Company in 1933 . . . Thus, sixty-six years of manufacturing fine products stands behind Lowex.

**OWENS-ILLINOIS GLASS COMPANY**

*"First in Glass"*

# OWENS-ILLINOIS

HEMINGRAY DIVISION — MUNCIE, INDIANA

## HEMINGRAY INSULATORS

*Favorably Known Since 1870*

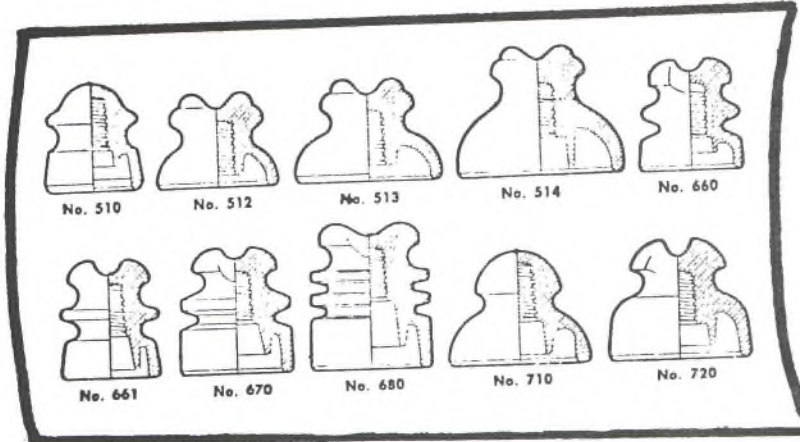

### HEMINGRAYS FOR PRIMARY POWER DISTRIBUTION

For voltages from 2,300 to 15,000 and manufactured in accordance with suggested specifications of the Edison Electric Institute.

### HEMINGRAYS FOR SECONDARY POWER DISTRIBUTION

With heights ranging from 2<sup>1</sup>/<sub>8</sub> to 5<sup>1</sup>/<sub>4</sub> inches and diameters ranging from 2<sup>1</sup>/<sub>8</sub> to 3<sup>1</sup>/<sub>4</sub> inches.

### HEMINGRAYS FOR TELEPHONE AND TELEGRAPH LINES

With heights ranging from 2<sup>3</sup>/<sub>16</sub> to 4<sup>9</sup>/<sub>32</sub> inches and diameters ranging from 2<sup>7</sup>/<sub>16</sub> to 3<sup>1</sup>/<sub>4</sub> inches.

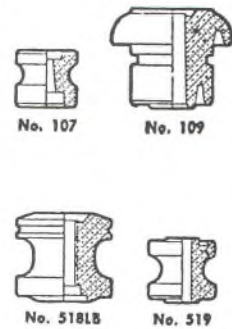
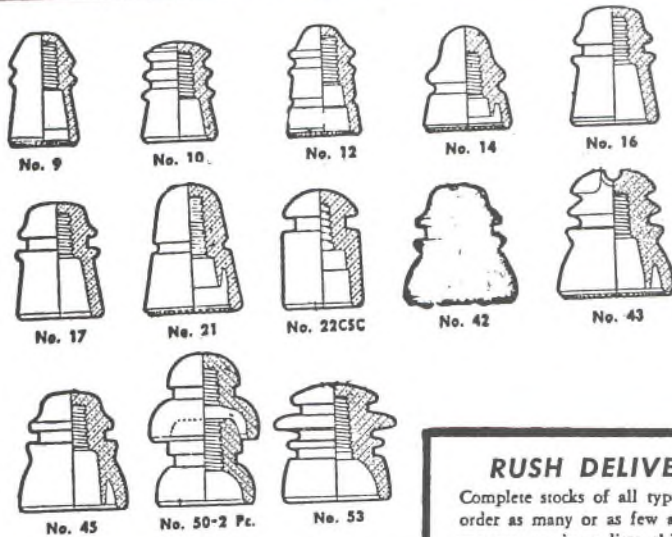
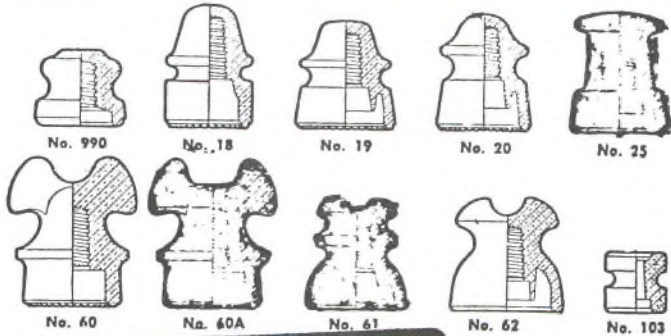

### RUSH DELIVERY IF YOU NEED IT!

Complete stocks of all types of Hemingrays are on hand. You can order as many or as few as you need. Just phone your jobber. He can arrange immediate shipment. Owens-Illinois, Hemingray Division, Muncie, Indiana.

Catalog page or brochure from Owens-Illinois.  
C. 1942-1944  
(Courtesy of Mike Sovereign and Glenn Drummond)

TRADE MARK  
STANDARD **HEMINGRAY** INSULATORS  
REGISTERED.



# THE "CATCH-ALL" ROOM



© 164





## A FEW NOTES ABOUT THE "CATCH-ALL" ROOM

Most of us have a room or a closet in our home where we place everything that we don't know where else to put. Well, that is what this section is. "The 'Catch-all' Room" holds speeches, histories, commentaries, a few illustration and photo explanations, patents, and anything else that would have disrupted the flow of the story had it been included where it belonged in the text. This way, the reader can take the time later on to look over these often lengthy documents.

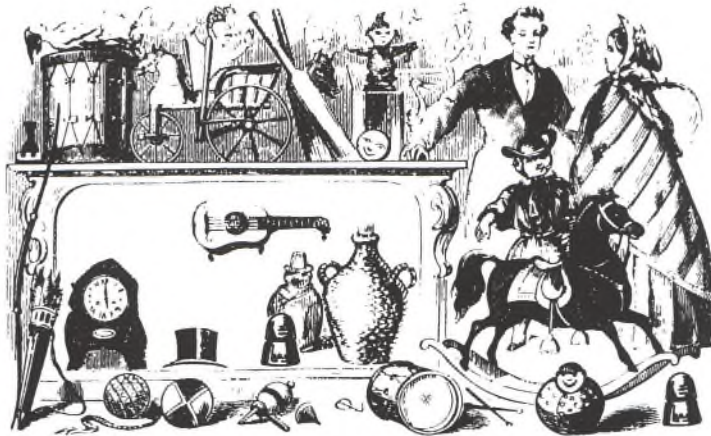

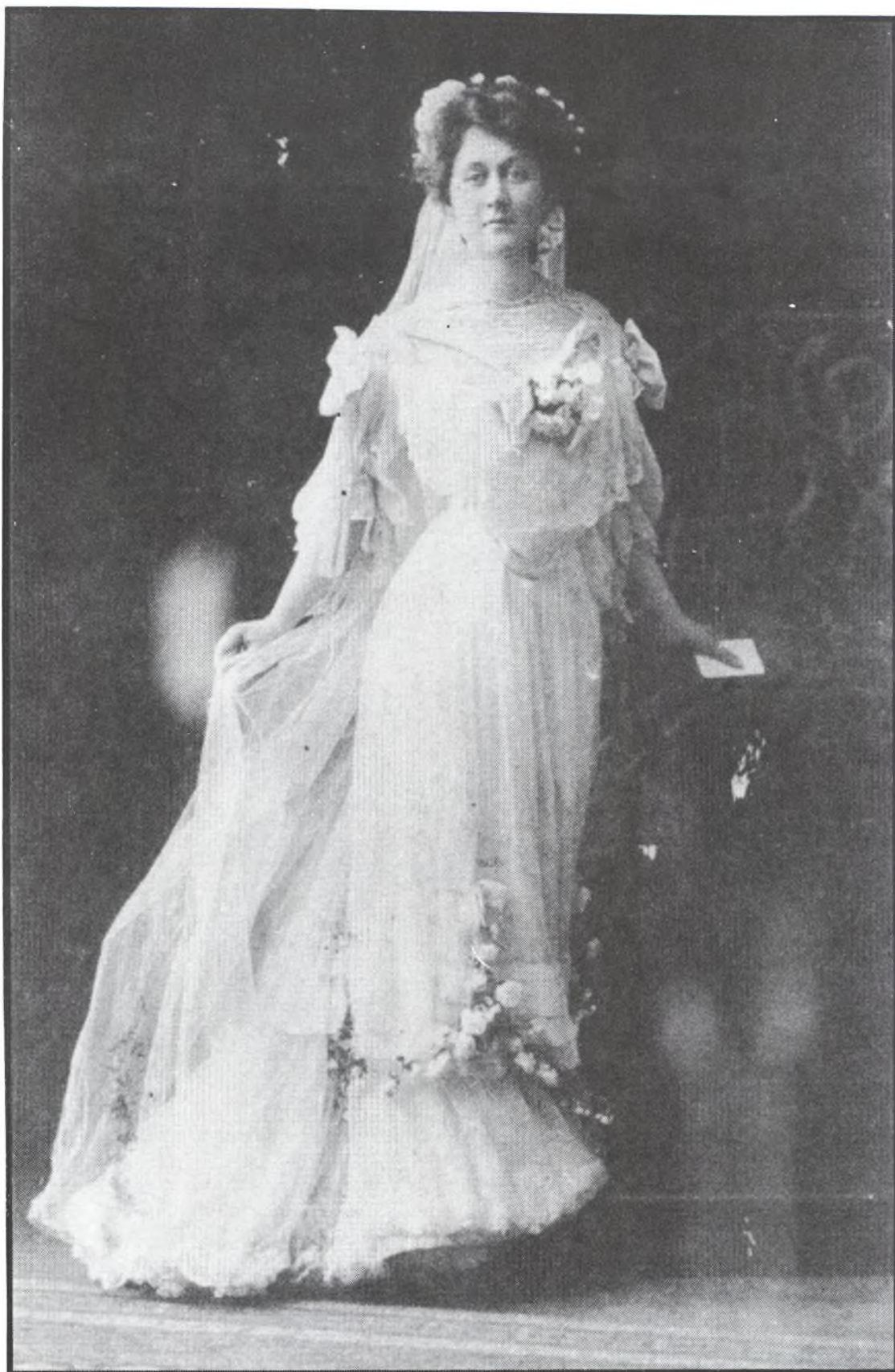

The Mystery Bride.  
Possibly (Mintie) Carroll Hemingray McAbee.  
Muncie, IN  
24 April 1907  
(Courtesy of Bill Morgan and Pat Mundy)



## THE MYSTERY BRIDE

We are not certain who this lovely bride is. The fact that the photo exists at all is a miracle of sorts. It was found in the attic of the Ralph Hemingray (and Philip McAbee) home at 824 E. Washington Street, Muncie. The current owners of the house, Bill Morgan and Pat Mundy, found it hidden behind a knee-wall, under two unused slate roof shingles. Who hid it, when was it hidden, and why? We will never know. It survived in its secret location for many years and through many house ownerships. Nothing is written on the photo, so we have no clues from that source as to who she is.

If she was a resident of the house, and a Hemingray, she can be only one of two people; Ralph Hemingray's second wife Eva Hollinger Hemingray, or Mintie Carroll Hemingray McAbee, wife of Philip McAbee, and daughter of Ralph Hemingray.

My personal feeling is that she is Ralph's daughter, Carroll. She definitely looks like him, but more like her uncle, Daniel. As proof of my theory, I offer the three photos below. You can make your own decision, but to me, there is a strong family resemblance.

In addition, Carroll and Philip were married in April 1907. I took copies of this photo to two different vintage clothing experts for their educated opinions. Independently of each other, they both came up with the late 1800s to early 1900s for the date. Two items were mentioned as explanations; the absence of a bustle, and the pouter pigeon blouse. Also the hair style was a clue.

I am so grateful to Bill Morgan and Pat Mundy for sharing this beautiful photo with me. It is certainly a highlight of my book. If anyone who reads this can identify this mystery bride, please write to me. Or, if another photo of Carroll is ever found, that could solve the mystery.



Ralph



Carroll?



Daniel

(See following page numbers for photo credits: Ralph, page 12;  
Carroll (?), page 384; Daniel, page 16)

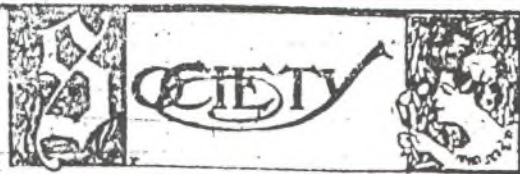

TELEPHONE TO THE SOCIETY EDITOR

When somebody visits you or you go away; when you entertain or are entertained, call two rings on 68, either phone, and tell the Society Editor about it.

HEMINGRAY--McABEE

Although the wedding of Miss Carol Hemingray and Mr. Philip McAbee this evening at 7:30 o'clock will be a quiet affair to which only relatives and out-of-town guests are invited, it will be one of the most beautiful in its appointments that has been celebrated in Muncie for many years. The Hemingray home on East Gilbert street where the service will be read by the Rev. W. H. Allen and where the reception will be held after the wedding, has been converted today by Carnes, the florist, into a veritable bower. The decorative effect throughout is pink and green. The walls of the entire house are draped in asparagus, while in the wall pockets of green plaids here and there are hung Eucharistic carnations and the chandeliers are massed with smilax. Where the bride and groom stand during the ceremony will be a bank of ferns.

The bride will carry a shower bouquet of orchids and lilies of the valley and her attendants will carry bouquets of immense pink roses. The three children who will attend the bridal pair will carry garlands of smilax and with ribbons will enclose the bridal party while the service is being read.

The floor of the house will be covered with canvas, making a pretty contrast to the green of the walls and the pockets. The porch has been enclosed by awnings. Electric lights will be scattered about the veranda. It is here that Hart's orchestra, of Indianapolis, which will furnish the music, will be placed.

The bridal gown which was made in Indianapolis, is of beautiful blue tulle trimmed in point lace with a berthia also of point lace. The prettiest garniture of the gown is the old point lace veil which is an heirloom that has been worn for many years by brides in the Hemingray family. This veil will be held in place by a wreath of ivy, carrying out in this way an old English custom.

Miss Hemingray will have as her maid-of-honor, her sister, Miss Lowell Hemingray, while Mrs. Mary McAbee, of Cleveland, O., a sister of the groom, will be the only bride-maid. The bride will present her bride-maid with a beautiful necklace whose pendant, a cluster of diamonds, is the gift of the groom.

The gift of the bride to the maid of honor is a gold bar pin, set with sapphires. The attendants will wear decollete gowns of pink point lace.

The groom's present to the bride will be a diamond and pearl necklace. The bride's present to the groom is an elegantly carved cigarette case with gold lining.

The best man will be William Martin, of Cleveland, O., and the groomsmen will be Albert Green, of Cleveland and Harry Wolf, of Muncie.

The gifts of the groom to his groomsmen are gold studs. To the grooms-women, who are Master Frank Cross, a cousin of the bride and Jack and Phillip Martin, are

gifts of the groom, he gives silver knives.

After the ceremony a reception for a few intimate friends and relatives will follow at 8:30 o'clock in the home where a wedding supper will be served. The bride's table will be exquisitely done in shades of pink. In a huge Tiffany glass vase in the center will be a shower of pink roses. In crystal candelabra and candlesticks will burn pink tapers. The caterer and attendants in charge of the supper are from Indianapolis.

The bride's going-away gown is a rust broadcloth, with hat to match. The bridal couple will depart this evening for Wisconsin on a wedding trip. They will be absent several weeks, after which they will be at home in the Birge apartment, Muncie.

Both Miss Hemingray and Mr. McAbee are socially prominent in Muncie and are well known also in several other cities where they have visited. Miss Hemingray is the daughter of Ralph G. Hemingray, the glass manufacturer, and Mr. McAbee is the son of Mrs. Newton McAbee, of Cleveland, Ohio. He is secretary of the Indiana Pipe company here.

The out-of-town guests are Mr. and Mrs. Bradford Shinkle, Dr. and Mrs. Frank Cross, Mr. and Mrs. Clifford Shinkle, Mr. and Mrs. S. J. Long, Mr. and Mrs. D. C. Hamilton, Miss Matthews and Mrs. Moore, all of whom are from Covington, Ky.; Miss Hamilton, of Cincinnati; Mrs. Lewis Matthews, of Springfield, Ohio; Mr. and Mrs. Rush Evans and daughter, Miss Ann Evans, of Baston, O.; Miss Marshall of Pittsburg; Mr. and Mrs. William Martin and Albert Green, all of Cleveland, O.; and Mr. and Mrs. J. H. Fisher and Horace Evans, all of Bedford, Cal.

(See typed version on next page)



The Muncie Press

24 April 1907  
Society

HEMINGRAY-McABEE

Although the wedding of Miss Carrol Hemingray and Mr. Philip McAbee this evening at 7:30 o'clock will be a quiet affair to which only relatives and out-of-town guests are invited, it will be one of the most beautiful in its appointments that has been celebrated in Muncie for many years. The Hemingray home on East Gilbert street where the service will be read by the Rev. W. H. Allen and where the reception will be held after the wedding, has been converted today by Carnes, the florist, into a veritable bower. The decorative effect throughout is pink and green. The walls of the entire house are draped in asparagus, while in the wall pockets of green placed here and there are hung Enchantress carnations, and the chandeliers are massed with smilax. Where the bride and groom stand during the ceremony will be a bank of ferns.

The bride will carry a shower bouquet of orchids and lillies of the valley and her attendants will carry bouquets of immense pink roses. The three children who will attend the bridal pair will carry garlands of smilax and with ribbons will enclose the bridal party while the service is being read.

The floor of the house will be covered with canvas, making a pretty contrast to the green of the walls and the pockets. The porch has been enclosed by awnings. Electric lights will be scattered about the veranda. It is here that Hart's orchestra, of Indianapolis, which will furnish the music, will be placed.

The bridal gown which was made in Indianapolis, is of beautiful white tulle trimmed in point lace with a berth also of point lace. The prettiest garniture of the gown is the old point lace veil which is an heirloom that has been worn for many years by brides in the Hemingray family. This veil will be held in place by a wreath of myrtle, carrying out in this way an old English custom.

Miss Hemingray will have as her maid-of-honor, her sister, Miss Lewellyn Hemingray, while Miss Mary McAbee, of Cleveland, O., a sister of the groom, will be the only bridesmaid. The bride will present her bridesmaid with a beautiful necklace, whose pendant, a cluster (illegible).

The gift of the bride to the maid-of-honor is a gold bar pin, set with sapphires. The attendants will wear decollette gowns of pink point d'esprit.

The groom's present to the bride is a princess ring, beautifully set with diamonds and pearls and the bride's present to the groom is an elegantly carved cigarette case with gold lining.

The best man will be William Martin, of Cleveland, O., and the groomsmen will be Albert Green, of Cleveland and Harry Wolf of Muncie.

The gifts of the groom to his groomsmen are gold studs. To the garland-bearers, who are Masters Frank Cross, a cousin of the bride and Jack and Phillip Martin, nephews of the groom, he gives silver knives.

After the ceremony a reception for a few intimate friends and relatives will follow at 8:30 o'clock in the home where a wedding supper will be served. The bride's table will be exquisitely done in shades of pink. In a huge Tiffany glass vase in the center will be a shower of pink roses. In crystal candelabra and candlesticks will burn pink tapers. The caterer and attendants in charge of the supper are from Indianapolis.

The bride's going-away gown is rust broadcloth, with hat to match. The bridal couple will depart this evening for Wisconsin on a wedding trip. They will be absent several weeks, after which they will be at home in the Ringold apartments, Muncie.

Both Miss Hemingray and Mr. McAbee are socially prominent in Muncie and are well known also in several other cities where they have visited. Miss Hemingray is the daughter of Ralph G. Hemingray, the glass manufacturer, and Mr. McAbee is the son of Mrs. Newton McAbee, of Cleveland, Ohio. He is secretary of the Indiana Pipe company here.

The out-of-town guests are Mr. and Mrs. Bradford Shinkle, Dr. and Mrs. Frank Cross, Mr. and Mrs. Clifford Shinkle, Mr. and Mrs. S. K. Long, Mr. and Mrs. D. C. Hemingray, Miss Matthews and Mrs. Morcom, all of whom are from Covington, Ky; Miss Hamilton of Cincinnati; Mrs. Lewis Matthews, of Springfield, Ohio; Mr. and Mrs. Rush Evans and daughter, Miss Ann Evans, of Dayton, O.; Miss Marshall of Pittsburgh; Mr. and Mrs. William Martin and Albert Green, all of Cleveland, O., and Mr. and Mrs. J. H. Fisher and Horace Evans, all of Redlands, Cal.

(A note of interest...following this wedding announcement was another for OLCOTT-BROOKS, whose ceremony took place the night before. In the bridal party was Miss Clara Gill, Miss Lewellyn Hemingray, Miss Carrol Hemingray, and Phillip McAbee. At the wedding was Daniel Hemingray, Mr. and Mrs. Bradford Shinkle, and Mr. and Mrs. Rush Evans and daughter.)

Note: This home was located at 411 E. Gilbert Street in Muncie. According to Bill Morgan, who was kind enough to check for me, the location where this house once stood is now a small park.



## SOCIAL AND PERSONAL VIEWS

### WEDDING CEREMONY

Pink and white, carried out in a profusion of roses and carnations, formed the color scheme at the home of Mr. R. G. Hemingray, on East Gilbert street, last evening, when at 12 o'clock the wedding of his daughter, Miss Carol Hemingray, and Philip McAbee was celebrated by the Rev. William H. Allen, pastor of the Jackson street Christian church.

The service was read in the living room, where the open stairway, screened with maid-hair and banked with palms and ferns, formed the background for the bridal party. The floors were covered with white and effectively arranged about the different rooms were green wall pockets filled with pink and white carnations and roses. The walls and doorways were adorned with ropes of maid-hair ferns, while the chandeliers were festooned with southern amilax. Hart's orchestra, of Indianapolis, gave a concert of love music as the wedding guests assembled, from the porch, which had been enclosed by awnings and illuminated by incandescents. The wedding was a beautifully arranged affair, though marked by elegant simplicity in all its appointments, with only the families of the bridal party and the out-of-town guests in attendance.

Mr. Hemingray gave his daughter away and the bridal gown was of white tulle with berries of point lace. Her point lace veil, which is an heirloom and has been worn for many years by brides in the Hemingray family, was held in place by a wreath of myrtle, and she carried a shower bouquet of valley lilies and white orchids. Miss Hemingray had as her maid of honor, her sister, Miss Catherine Hemingray, and Miss Mary McAbee, of Cleveland, sister of the groom, was the only bridesmaid. Both were attired in pink point d'esprit, with empire girdles, and each carried an armful of pink roses. The maids wore the gifts of the bride, a gold hair pin with sunken sapphires to her sister and a fourteen necklace of pearls to Miss McAbee. The bridal party was completed by William Martin, of Cleveland, who served as best man, and the groomsmen, Albert Green, of Cleveland, and Harry Wolf, of this city. Three little boys, Philip and Jack Martin, of Cleveland, nephews of the groom, and Frank Cross, of Cincinnati, a cousin of the bride, served as ring bearers. The groom's gift to the bride was a princess ring set with pearls and diamonds; to the men of the party, gold shirt buttons, and to the ribbon bearers, silver knives. The bride's gift to the groom was an etched cigarette case, gold lined with ribbon monogram.

An informal reception for the intimate friends followed the ceremony and a buffet supper was served in the dining room during the evening.

Mr. and Mrs. McAbee left last evening on their honeymoon, which will be spent in Wisconsin, and on their return, about the middle of May, they will be "at home" in the Ringold apartments.

The guests at the wedding included Mr. and Mrs. Bradford Shinkle, Mr. and Mrs. Samuel Long, Mrs. Morcom and Miss Matthews, of Covington, Ky.; Dr. and Mrs. Frank Cross, Mr. and Mrs. Clifford Shinkle and Miss Hamilton, of Cincinnati, all of whom came to this city in a private car; Mr. and Mrs. J. H. Fisher, Mrs. Horace Evans and Miss Eleanor Evans, of Redlands, Cal.; Mr. and Mrs. William Martin, Miss Virginia Martin and Albert Green, of Cleveland; Mr. and Mrs. Ruth Evans and Miss Anna Evans, of Dayton; Miss Marshall, of Hillsburg; Mr. Matthews, of Springfield; Mr. and Mrs. Guy C. Pierce, of Chicago; Mrs. P. Atwood Hinds, of Mansfield, O.; Mrs. Lynn Stone, of Indianapolis.

The Muncie Morning Star

25 Apr 1907

(Courtesy of Pat Mundy)

(See typed version on next page)

The Muncie Morning Star

25 April 1907

Social and Personal News

Evening ceremony

Pink and white, carried out in a profusion of roses and carnations, formed the color scheme at the home of Mr. R. G. Hemingray, on East Gilbert street last evening, when at 7:30 o'clock the marriage of his daughter, Miss Carrol Hemingray, and Philip McAbee was solemnized by the Rev. William H. Allen, pastor of the Jackson street Christian church.

The service was read in the living room where the open stairway, screened with maidenhair and banked with palms and ferns formed the background for the bridal party. The floors were covered with white and effectively arranged about the different rooms were green wall pockets filled with pink and white carnations and roses. The walls and doorways were adorned with ropes of maidenhair ferns, while the chandeliers were festooned with southern smilax. Hart's orchestra of Indianapolis gave a concert of love music as the wedding guests assembled from the porch, which had been enclosed by awnings and illuminated by incandescent lights. The wedding was a beautifully arranged affair, though marked by elegant simplicity in all its appointments, with only the families of the bridal party and the out-of-town guests in attendance.

Mr. Hemingray gave his daughter away and the bridal gown was of white tulle with bertha of point lace. Her point lace veil, which is an heirloom and has been worn for many years by brides in the Hemingray family, was held in place by a wreath of myrtle, and she carried a shower bouquet of valley lillies and white orchids. Miss Hemingray had as her maid of honor, her sister, Miss Llewellyn Hemingray, and Miss Mary McAbee, of Cleveland, sister of the groom, was the only bridesmaid. Both were attired in pink point d'esprit with empire girdles and each carried an armful of pink roses. The maids wore the gifts of the bride, a gold bar pin with sunken sapphires to her sister and a festoon necklace of pearls to Miss McAbee. The bridal party was completed by William Martin of Cleveland, who served as best man and the groomsmen, Albert Green, of Cleveland, and Harry Wolf of this city. Three little boys, Philip and Jack Martin of Cleveland, nephews of the groom, and Frank Cross of Cincinnati, a cousin of the bride, served as ribbon bearers. The groom's gift to the bride was a princess ring set with pearls and diamonds; to the men of the party, gold shirt buttons, and to the ribbon bearers, silver knives. The bride's gift to the groom was an etched cigarette case, gold lined with ribbon monogram.

An informal reception for the intimate friends followed the ceremony and a buffet supper was served in the dining room during the evening.

Mr. and Mrs. McAbee left last evening on their honeymoon, which will be spent in Wisconsin, and on their return about the middle of May, they will be "at home" in the Ringold apartments.

The guests at the wedding included Mr. and Mrs. Bradford Shinkle, Mr. and Mrs. Samuel Long, Mrs. Morcom and Miss Matthews of Covington, Ky.; Dr. and Mrs. Frank Cross, Mr. and Mrs. Clifford Shinkle and Miss Hamilton, of Cincinnati, all of whom came to this city in a private car; Mr. and Mrs. J. H. Fisher, Mrs. Horace Evans and Miss Eleanor Evans of Redlands, Cal.; Mr. and Mrs. William Martin, Miss Virginia Martin and Albert Green of Cleveland; Mr. and Mrs. Rush Evans and Miss Anna Evans of Dayton; Miss Marshall of Pittsburgh; Mr. Matthews of Springfield; Mr. and Mrs. Guy C. Pierce of Chicago; Mrs. P. Atwood Hinds of Mansfield O; Mrs. Lyna Stone of Indianapolis.



The Hemingray Glass Company of Muncie...is recognized as the largest manufacturer of glass insulators in the world. For thirty-five years the Hemingray plant on Macedonia avenue [sic] has been regarded as one of the most stable industrial institutions in Muncie. Coming in here...following the opening of the natural gas field hereabout in the late '80s, the Hemingray plant has ever since been a large employer of labor...while the worldwide distribution of its products has done much to extend the name and fame of "Magic Muncie"... In the summer of 1892...the plant was destroyed by fire...The plant was rebuilt better than before and was going strong when the adverse effects of the Wilson tariff bill in 1894 began to be felt not only by this company but by the glass industry generally throughout the country...In the summer of 1893 Muncie suffered an epidemic of smallpox which resulted in a general quarantine against the city and the practical shut-down of all industries in the town...Banking troubles in the town were being ironed out at the same time...which was trying to all local industries...The Hemingray plant weathered all these storms...and...was in a strong position to meet the market which opened out...and its progress since then has been practically uninterrupted...Its chief products when it became established in Muncie were lamps, lamp globes, table ware, and hollow glassware generally...but with the... expansion of the telephone and telegraph industry about 1900 it began to give its chief attention to the manufacture of glass insulators and these in time became its sole product... The plant employs at maximum production about five hundred persons and its products are known wherever electric wire construction is known. The present officers of the company are Philip W. McAbee, president; A. Clifford Shinkle, of Cincinnati, vice president; W. P. Zimmerman, secretary; Charles S. Berger, treasurer; and C. H. Smith, assistant treasurer.

Excerpts from the History of Delaware County, Indiana, Vol. II,  
by Frank D. Haimbaugh,  
1924

(Courtesy of Ruth Crawford, the Muncie Public Library,  
and Rosella Cartwright)

## History of Muncie Owens-Illinois

The Hemingray Glass business was founded in Cincinnati in 1848 by Mr. Robert Hemingray, who continued to be active in the business until his death. Other partners and relatives were active in the management of the company throughout the years. In [1861] the manufacturing plant was moved from Hammond Street in Cincinnati across the Ohio River to Covington, Kentucky. At first the company made lamps and lamp chimneys and some novelty and container ware. With the use of electricity becoming wide spread, Glass insulators became a large part of its production. Floods and fires plagued the operation in Covington, so in 1887-88, the operators of the business purchased land and opened a new plant on Macedonia Ave. in Muncie. Muncie was chosen because it was the center of an apparently inexhaustible supply of natural gas.

Telephone and telegraph lines were being built at a fantastic rate throughout the country and the world. Now most of the production facilities of the company were given over to making and marketing glass insulators. Through the years various patents for the process of this item were granted to the company. Insulators remained the mainstay of the company until the late 1920s, when bottle production was started.

In 1933, the Hemingray interests were merged with those of the Owens-Illinois. Both bottles and insulators were produced although a severe depression caused the plant to suspend operations on more than one occasion.

Then in 1934, a new product was developed, this being the glass building block. Soon this item became a standard architectural building article, and many millions were produced and sold. During World War II, glass land mines were produced and sold to the armed services. After this period, the use of cables and other electrical advances made the production of insulators of less demand. In 1964-65 production of television face panels and funnels was begun at the Muncie plant. On March 1, 1966, the manufacture of glass block and insulators was stopped, and the facilities of the plant given over entirely to television parts production. At the present, the manufacture and processing of 25 inch color television face panels is the sole activity of the Muncie installation.

Although many changes in name, such as American Structural Products, Owens-Illinois, Kimble, and others have taken place, the plant itself is still located within the grounds of the original Hemingray purchase.

A short history of the company. It was either a speech, a press release, or a history compiled at someone's request.

C. 1968

(Courtesy of Glenn Drummond)



# LAWS OF KENTUCKY.

## CHAPTER 947.

AN ACT to incorporate the Hemingray Glass Company.

*Be it enacted by the General Assembly of the Commonwealth of Kentucky:*

§ 1. That Robert Hemingray, Richard Evans, James L. Foley, and such other persons as may become associated with them, be, and are hereby, created a body-politic and corporate, by the name and style of the "Hemingray Glass Company," with perpetual succession; and by that name may contract and be contracted with, sue and be sued; purchase, hold, sell and convey, such real and personal estate as shall be deemed necessary for the company in the transaction of its business.

§ 2. That the capital stock of said company shall be two hundred and fifty thousand dollars, divided into shares of one hundred dollars each, payable as the board of directors may determine. The capital may be increased to five hundred thousand dollars. Regular certificates of stock shall be issued, and be transferable on the books of the company only in person or by attorney duly authorized.

§ 3. The business of said company shall be under the care and management of a board of not less than three nor more than seven directors, as the by-laws may prescribe. The three persons named in the first section shall serve as directors until the first Saturday of January next, and until their successors shall be chosen; and then and thereafter the stockholders shall, annually, on the first Saturday in January, elect a board of directors, who shall serve one year, and until their successors shall be elected.

§ 4. At all elections of officers stockholders shall be allowed one vote for each share of paid up stock, and may vote in person or by proxy, but by ballot.

§ 5. The directors shall elect one of their own body president, and one vice president; shall also have a secretary and treasurer. The president, vice president, and directors must be stockholders. The same person may act as secretary and treasurer.

§ 6. The board of directors may adopt such rules, by-laws, and regulations for the control of the officers, agents, employees, and affairs of the company, and amend the same at pleasure; have and use a seal, and change it when deemed proper; appoint all officers and agents, and prescribe how and by whom employees shall be engaged; fix all salaries, and direct the wages of employees.

§ 7. The business of said company shall be the manufacture, in Covington, of glass in all its branches, and such articles connected with said business, or which is usual or may be made or manufactured in such establishments; and in dealing in glass, glassware, trimmings, and the articles of the trade or merchandise connected or usual therewith; and in the stock or raw materials in such other places, either in or out of this State, as they may desire; and may mine and transport any of the material out of which glass is usually manufactured; and do all acts and business competent for corporations to perform engaged in such business.

§ 8. The board shall keep a record of their proceedings, and copies therefrom, signed by the president or vice president, and attested by the secretary, under the seal of the company, shall be evidence in all courts and places.

§ 9. This act shall take effect from its passage.

Approved March 21, 1870.

---

Act of Incorporation.

Laws of Kentucky

1870

(Courtesy of Glenn Drummond)



## DRIP POINTS

I said in the "Forward" that I wasn't going to go into too many details in my book on patents the Hemingrays held on various items, but I'd like to make one exception with drip points. I have always loved drip points, so it is strange that my favorite insulator, although a Hemingray product (the H. G. CO. PETTICOAT beehive), does not have them. Even though they were designed to be practical, I've always considered them to be eye-pleasing, the final perfect touch. In fact, there's nothing more beautiful to me insulatorwise than looking up through the bottom of a CD 151 H. G. CO. NATCO in that rich, dark peacock blue, and observing that double row of drips, especially when they are all in mint condition.

As mentioned earlier, the drip point patent was issued 2 May 1893 to Ralph G. Hemingray and James C. Gill (see patent following this commentary). The data below is taken from The Glass Insulator in America-1988 Report, by Mr. N. R. Woodward, and is reprinted with permission. On page 13 he states:

*[This patent] concerned drip points, which were placed on the outside skirt or occasionally on an inner skirt as well, for the alleged purpose of giving better drainage during rainstorms. There is doubt as to the importance of this addition; and technical writers of the time expressed the belief that drip points, as well as other refinements of that order, were of little real value. Nevertheless the drip points were added to most Hemingray insulators thereafter for a period of approximately 40 years. Not until the 1930s did the drip points begin to disappear from the Hemingray line: and even to the last, some styles were made with them. The modern drip points are perfect hemispherical beads arranged in close formation around the base of the skirt, and are much stronger and less apt to break off than were the earlier ones. Some of these were long and sharp-pointed, and so easily broken that it is difficult indeed to locate an insulator with all of them intact.*

*After the 1893 patent expired, several other manufacturers added drip points to their insulators, some only to a very limited extent. But the appearance of the drip points on the Hemingray insulators was so universal for a long period of time that they must be considered as typically a Hemingray feature: and regardless of their importance from a technical standpoint, they do indeed present a unique and artistic finish.*

I wrote to Mr. Woodward in 1993 regarding how the drip point molds were made, and asking whether or not they were easily broken when the insulator was removed from the mold. He told me that they were made with a drill bit set in a jig to cut to a specific depth into the cast iron base rim. The shape of the points depended on the configuration of the bit that made the holes for them. As for removing them from the mold, when the time came to remove that portion of the mold, it was lifted straight up and away, causing no damage to the drips. (No doubt many were ruined shortly afterward, when

the insulators were put on the racks to cool down, and in packing. Many drips that survived the factory abuse no doubt lost their points when handled by linemen, or when shot at by insulator "sportsmen"!)

Interestingly, the term "drip points" is not used in the patent specs. They are called "lugs or teats". The closest the inventors get to "drip points" is to say that the insulator is "provided with a series of teats...to attract and gather at their points the drops of water running down the outer surface of the insulator...". Close, but not quite! Just when the term "drip points" was first used isn't known exactly. The 1903 Hemingray catalog states that "Points or teats are added...".

Mr. Woodward states that as early as 1904 he has reference to them as "drip points" in technical writing, not related to a specific manufacturer. But at that time the Hemingray patent would still be in effect. The 1912 Brookfield catalog refers to "drip points"; and the 1921 Hemingray catalog calls them "drip points or teats".

On the 100th anniversary of the drip point patent, Carol McDougald devoted much of the May 1993 issue of Crown Jewels of the Wire to that event in insulator history. Those of you who would like to know more about the drip points might want to read that issue, especially the fine article by Mr. N. R. Woodward which begins on page 7.





INCOMPLETE LIST OF REGISTERED TRADEMARKS AND PATENTS  
GRANTED TO HEMINGRAY AND OWENS-ILLINOIS AND/OR THEIR ASSIGNORS

L=Letters, D=Design, R=Reissue, T=Trademark

List compiled from information received from  
Glenn Drummond (1), Mr. N. R. Woodward (2), Fred Padgett (3), and Bob Stahr (4)

30,063L	18 Sep 1860	Glass jar mold	Robt. Hemingray	1
38,820L	9 Jun 1863	Fruit jar cap	R. Gray/R. Hemingray	1
48,399L	27 Jun 1865	Closing fruit jars	Robt. Hemingray	4
3,436D	30 Mar 1869	Lamp chimney	Robt. Hemingray	1
122,015L	19 Dec 1871	Molding teleg. insulators	Robt. Hemingray	1,2
160,016L	23 Feb 1875	Paper perforating machine	Robt. Hemingray	1
8,942D	1 Feb 1876	Bird dishes	Julius Proeger	4
196,092L	16 Oct 1877	Cleaning glass from ends of blow-pipes	Ralph Hemingray	1
10,678D	14 May 1878	Lampshade	Robt. Hemingray	1
8,600R	25 Feb 1879	Oil can	Wm. H. Bartels	1
212,850L	4 Mar 1879	Machine for flaring/crimp- ing lamp chimneys	Robt. Hemingray	1
242,825L	14 Jun 1881	Glass press for insulators	Robt. Hemingray	1,2
290,771L	25 Dec 1883	Glass batch mixer	Ralph Hemingray	1
342,602L	25 May 1886	Fastener for jar tops	Robt. Hemingray	1
17,148D	1 Mar 1887	Knights of Labor matchsafe	James C. Gill	4
27,001L*	20 Jun 1887	Fastener for jar tops	Robt. Hemingray	4
406,041L	2 Jul 1889	Ins. for electric wires	James C. Gill	1,2
496,652L	2 May 1893	Ins. for telegraph wires (drip points)	Ralph Hemingray/ James C. Gill	1,2
588,795L	24 Aug 1897	Glass press	Ralph Hemingray	1,2
614,303L	15 Nov 1898	Glass press	Ralph Hemingray	1,2
30,637D	25 Apr 1899	Design for insulator	V. G. Converse	2
686,609L	12 Nov 1901	Ins. support for elec. wires	Ralph Hemingray	1,2
39,727T	3 Feb 1903	GLOBE trademark	H. G. Company	4
866,787L	24 Sep 1907	Producer gas furnace	Ralph Hemingray/ J. O. Jensen	4
909,595L	12 Jan 1909	Screw press to form ins.	Ralph Hemingray/ C. Hawk	2
78,096T	31 May 1910	HEMINGRAY trademark	H. G. Company	2
131,661R	23 Dec 1913	Reissue of 909,595L	Ralph Hemingray/ C. Hawk	4
1,088,278L	24 Feb 1914	Rain guard for insulators	Minot K. Holmes	2
1,133,244L	23 Mar 1915	Glass working machine	Minot K. Holmes	2
1,193,787L	8 Aug 1916	Glass working machine	Minot K. Holmes	2,4
1,193,788L	8 Aug 1916	Glass furnace	Minot K. Holmes	2,3
1,501,602L	15 Jul 1924	Leer feeder	Minot K. Holmes	4
1,642,658L	13 Sep 1927	Glass working machine	Minot K. Holmes	2,4
1,678,942L	31 Jul 1928	Mechanical movement (press)	Minot K. Holmes	2
78,096T	31 May 1930	HEMINGRAY trademark renewal	H. G. Company	2
82,326D	21 Oct 1930	Bottle design	Minot K. Holmes	4
312,912T	3 Apr 1931	HB trademark	H. G. Company	2
84,313D	2 Jun 1931	Bottle design	Willard P. Zimmerman	4
85,082D	15 Sep 1931	Water bottle	Ernest E. Bilby	2
86,659D	5 Apr 1932	Water bottle	Ernest E. Bilby	2
370,320T	22 Aug 1939	LOWEX trademark	Owens-Illinois	2
78,096T	31 May 1950	HEMINGRAY trademark renewal	Am. Struc. Prod. Co.	2

\* Canadian patent.

Note: There are many patents that Hemingray obtained license to manufacture, and these are not listed here. Example: Oakman patents.

# UNITED STATES PATENT OFFICE.

RALPH G. HEMINGRAY, OF COVINGTON, KENTUCKY, AND JAMES C. GILL,  
OF MUNCIE, INDIANA.

## INSULATOR FOR TELEGRAPH-WIRES.

SPECIFICATION forming part of Letters Patent No. 496,652, dated May 2, 1893.

Application filed January 3, 1893. Serial No. 467,057. (No model.)

*To all whom it may concern;*

Be it known that we, RALPH G. HEMINGRAY, of Covington, county of Kenton, State of Kentucky, and JAMES C. GILL, of Muncie, county of Delaware, State of Indiana, citizens of the United States, have invented certain new and useful Improvements in Insulators for Telegraph-Wires and the Like, of which the following is a full, clear, and exact description, reference being had to the accompanying drawings, forming part of this specification.

Our improvements relate to insulators in which means are devised to obtain as perfect insulation as possible, and to prevent the water which collects on the insulator during rains, from effecting the insulation, by coating the surface of the insulator and thus forming connection between the wire and the insulator support.

In the drawings:—Figure 1 is a side elevation of our improved insulator. Fig. 2, is a central vertical section of the same.

A, is the body of the insulator made of glass, porcelain or other suitable insulating material.

B, is the usual groove for the tie-wire, by which the main wire is secured to the insulator. The insulator is molded with a screw threaded recess C in the usual way, by means of which the insulator is secured to its support. The insulator shown is further provided with what is known as a "double petticoat," which consists of the inner shield D and the outer shield E, with the recess a, between the two shields or "petticoats." This double shield or double petticoat arrangement, has been long in use, to present a broad weather protected surface between the lower outer edge of the insulator and the support, the idea being to obtain such a broad surface that water running down the outside of the insu-

lator, will not be able to find its way to the supporting peg.

It is to obtain a more perfect insulation than has been obtained by this arrangement, that our invention is directed. To accomplish this result, we mold or secure at the lower edge of the flaring bell-mouth of the insulator, a series of lugs or teats *b, b*. These teats are arranged in series around the lower edge of the insulator and preferably so close together, as to attract and receive on their rounded points, all drops of water that may run down the sides of the insulator. With this construction the teats *b* attract and draw to their points, where they drop off one at a time, all drops of water which would otherwise gradually extend themselves by capillary attraction over the inner surface of the insulator. We find in practice that a single row of these teats arranged on the lower edge of the insulator, is sufficient, but when desired, of course the inner shield D could be provided with a similar series of teats.

Of course we do not wish to be limited to the particular class of "double petticoat" insulators shown in the drawings, as our series of teats can be formed on the lower edge of any of the well known forms of insulators.

Having thus described our invention, what we claim, and desire to secure by Letters Patent, is—

An insulator, provided with a series of teats at the lower edge of the insulator shield, to attract and gather at their points the drops of water running down the outer surface of the insulator, substantially as described.

RALPH G. HEMINGRAY.  
JAMES C. GILL.

Witnesses:

J. W. BARTLETT,  
C. L. GRIFFITH.

Drip point patent.

(Courtesy of Mr. N. R. Woodward and Bill and Jill Meier)



(No Model.)

R. G. HEMINGRAY & J. C. GILL.  
INSULATOR FOR TELEGRAPH WIRES.

No. 496,652.

Patented May 2, 1893.

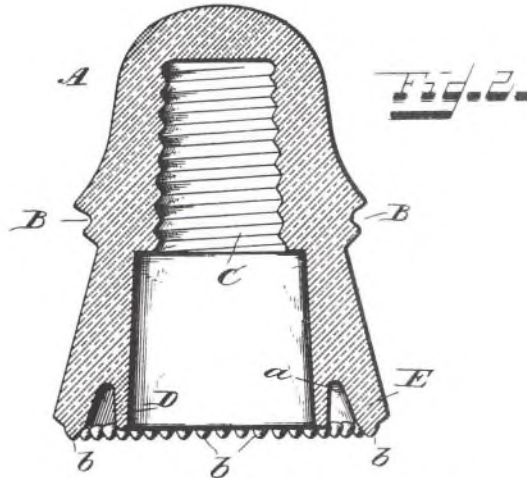
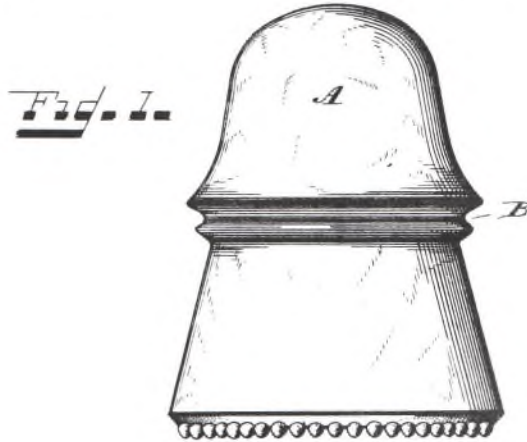

Witnesses:  
*J. Thomson Cross*  
*George Aidman*

Inventors:  
*Ralph G. Hemingray*  
*James C. Gill*  
by *Steu Vallan*  
Attorneys.

# UNITED STATES PATENT OFFICE.

ROBERT HEMINGRAY, OF COVINGTON, KENTUCKY.

## IMPROVEMENT IN MOLDING TELEGRAPH-INSULATORS.

Specification forming part of Letters Patent No. 122,015, dated December 19, 1871.

### To all whom it may concern:

Be it known that I, ROBERT HEMINGRAY, of Covington, Kenton county, Kentucky, have invented a new and useful Process in Molding Telegraph-Insulators, of which the following is a specification:

The customary glass insulator for telegraphic purposes consists of an inverted cup of cylindrical or conoidal form grooved exteriorly for the telegraph-wire, and having an interior cavity of two unequal diameters, the deeper and narrower portion being screw-threaded, as shown in the accompanying drawing. This partially screw-threaded cavity was formerly made at one operation by sinking into the lump of molten glass within the mold a former or mandrel of corresponding form, which was afterward screwed out from the mold; but this mode was subject to serious difficulties, owing to the liability of the mandrel to become heated and stick to the intensely-heated lump of glass.

To obviate this difficulty, I devised and made application for a patent for a plan whereby the entire cavity was created by a simple cylindrical plunger, and the thread subsequently formed on the narrower portion by a screw-threaded mandrel, which, having accomplished its purpose, was unscrewed from the glass; but this plan, although better than the first named, was found in practice to be subject to the opposite defect, the glass becoming too much chilled before the second mandrel could be inserted to produce a deep smooth and otherwise perfect thread. I now accomplish the purpose with complete success by a mode of operation intermediate in character and result, yet distinctly different in means from the above. The said mode of operation consists in, first, by means of suitable mold and plunger, forming a blank with external groove and the larger unthreaded portion of the cavity, and while the body of glass at bottom of the said partial cavity is yet hot sinking into it a properly screw-threaded mandrel having a collar to preserve the proper form of the non-threaded and wider portion of the cavity, which collar is, preferably, in the form of a cylindrical sleeve, that, resting by its weight upon the portion of glass which surrounds the mandrel proper, yields to the ascent of said glass as it is displaced by the mandrel and imparts the proper finish.

In the accompanying drawing, Figure 1 is a

perspective view of the preferred form of my improved plunger or mandrel and its appurtenances. Fig. 2 is an axial section of the same. Figs. 3 and 4 represent, by axial sections, the successive stages in the manufacture of the instrument on my plan. Fig. 5 is an axial section, showing my plunger in position within the mold. Fig. 6 is a longitudinal section of the finished insulator.

A A' may represent the two parts of a suitable mold for forming the exterior of the insulator. a a' are orifices in the top of the mold to hold the pins B B' of annular guide-head or plate C, which rests upon the top of the mold. Rising from the plate C is a spider, D, whose orifice d receives and guides the stem E of my screw-threaded mandrel or plunger F. This stem has a shoulder, f, and a handle, G, which co-operate with a spiral spring, H, to hold the mandrel to its proper normal position when not in use. I is a sliding collar or sleeve, whose upper central orifice engages around the mandrel-stem, and whose lower portion surrounds the threaded portion of the mandrel. This sleeve, as the molten glass rises in the mold by the displacement of the descending plunger, by preventing the irregular ascent of the said glass imparts the proper form to the shoulder which marks the boundary between the threaded and unthreaded portions of the cavity. In addition to the use mentioned above, the spiral spring H, by counteracting the weight of the mandrel, facilitates its extraction from the completed insulator, which act is effected by simply unscrewing the mandrel therefrom. The spiral spring also operates to keep the plate C in position on the top of the mold when in rest.

The expression "cylindrical" will be understood by practical men to admit such slight draft or taper as will permit ready extraction from the mold of the parts thus designated.

While describing the preferred form of my invention, I reserve the right to vary the same—for example, an inferior modification of my invention might have the collar fixed permanently at the proper height upon the mandrel, but such unyielding collar would be objectionable because, if too much glass were taken into the mold it would be impossible to insert the plunger to its proper depth, and if too little glass were introduced the proper finish to the shoulder would not be given.

I claim herein as new and of my invention—

122,015

2

1. The mode or process of forming the cavity in telegraphic insulators by first forming the unthreaded wider portion of the cavity by a threadless plunger, and, while the glass is yet hot, forming the threaded deeper portion by means of a screw threaded plunger or mandrel, substantially as set forth.

2. The described combination, with the mandrel F, of the collar or sleeve I, whether yielding or otherwise.

3. In the described combination with the mandrel F, the spring H, for the purpose designated. In testimony of which invention I hereunto set my hand.

R. HEMINGRAY.

Witnesses:

GEO. H. KNIGHT,  
JAMES H. LAYMAN.

(68)

Patent for molding glass telegraph insulators.

19 Dec 1871

(Courtesy of Mr. N. R. Woodward and Bill and Jill Meier)



R. HEMINGRAY,

Moulding Glass Telegraph Insulators.

No. 122,015.

Patented Dec. 19, 1871.

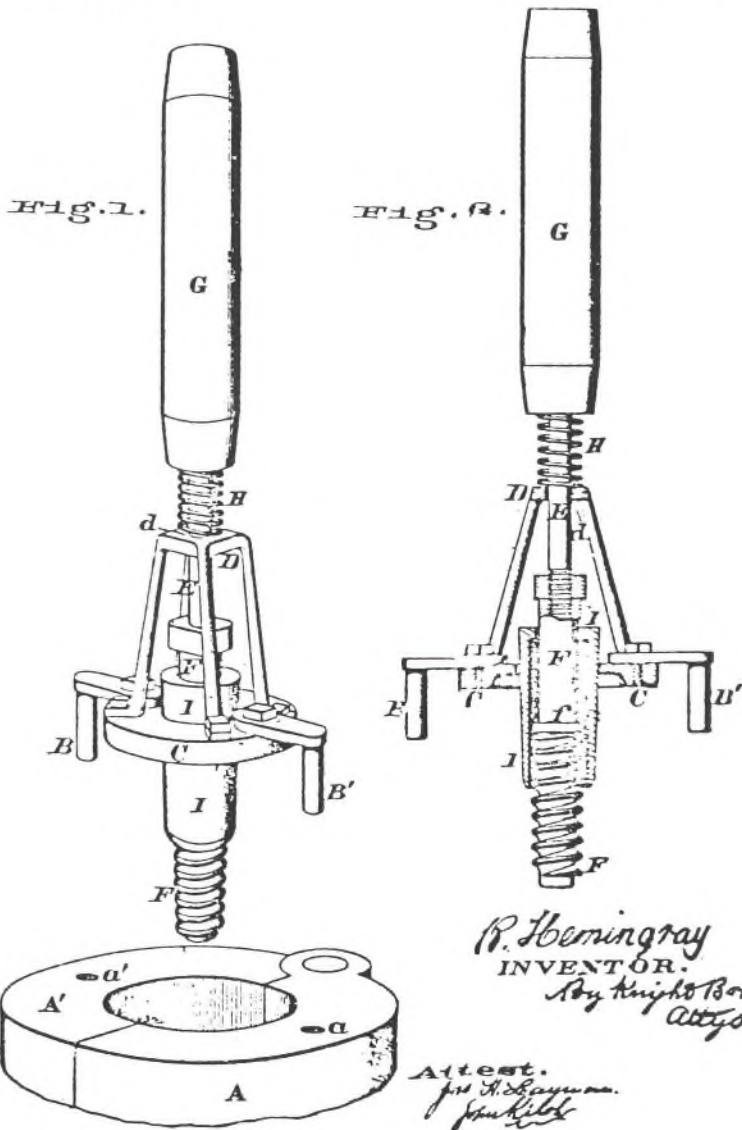

*R. Hemingray*  
 INVENTOR.  
*Ray Knight Boss*  
 Atty.

Attest.  
*Jos. H. Bayman*  
*Jos. H. Bayman*

R. HEMINGRAY.

Moulding Glass Telegraph Insulators.

No. 122,015.

Patented Dec. 19, 1871.

Fig. 3.

Fig. 4.

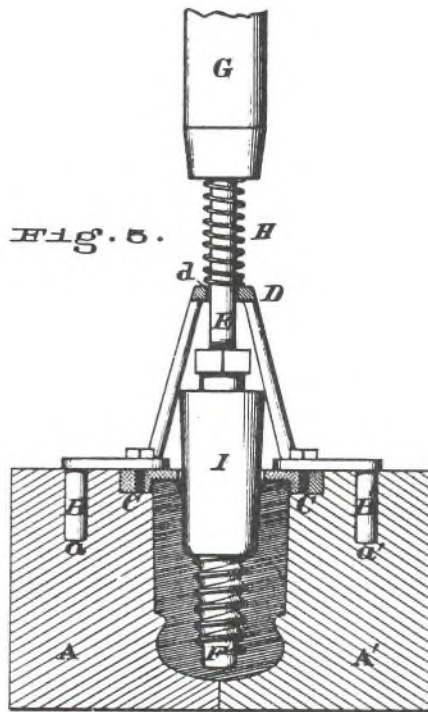
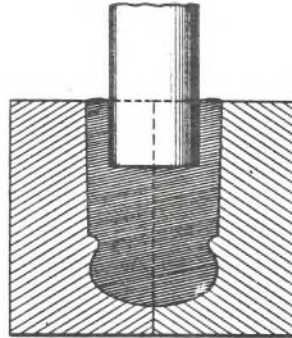
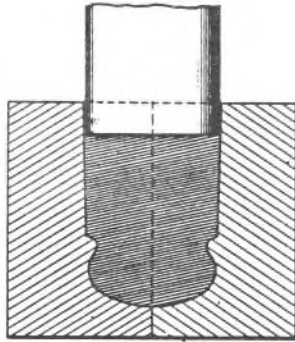
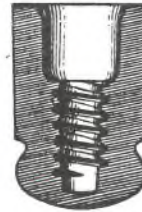

Fig. 6.



*R. Hemingray*  
 INVENTOR.  
*By Hughes Bros*  
 Attys

Attest.  
 *Jas H. Gayman.*  
 *John Kilb*



# UNITED STATES PATENT OFFICE.

SAMUEL OAKMAN, OF MELROSE, MASSACHUSETTS, ASSIGNOR TO THE  
AMERICAN INSULATOR COMPANY, OF NEW YORK.

## TELEGRAPH-INSULATOR.

SPECIFICATION forming part of Letters Patent No. 288,360, dated November 13, 1882.

Application filed July 30, 1880. (No model.)

*To all whom it may concern:*

Be it known that I, SAMUEL OAKMAN, of Melrose, in the county of Middlesex and State of Massachusetts, have invented certain new and useful Improvements in Telegraph-Insulators, of which the following is a specification.

My invention relates to that class of glass insulators which are supported upon screw-pegs, and has for its object to so construct the interior of the insulator that it shall have a broad interior band of weather-protected surface for insulation between the exterior of the insulator and the supporting-peg; also, in providing the interior of the insulator with an annular recess for the reception of paraffine or some similar moisture-repellent. These objects I attain by the mechanism illustrated in the accompanying drawings, in which—

Figure 1 is an elevation of one of my insulators, and Fig. 2 is a cross-vertical section of the same.

In the drawings, A B C represent the body of the insulator. This insulator has a screw-thread, D, formed on its interior, as shown in Fig. 2, of the ordinary style and dimensions of the standard insulators now in general use. I also form on the interior surface an annular recess, C', which serves to receive a coating or body of paraffine or other moisture-repellent. Immediately below the recess C' I form the annular shield E and the upwardly-projecting recess H.

By the above-described construction I attain, in connection with the internal screw, D, an interior insulating-surface, 1 2 3 4 5 6, Fig. 2, a part of which—viz., the part 2 3—is especially adapted to receive and retain paraffine. Another part—viz., the part 3 4—is doubly protected from the weather; and a third part, 4 5 6, adds to the interior insulating-surface.

The arrangement of the interior of a screw insulator, as above described, gives a great advantage over the ones now in use. By it I am enabled to obtain in a single moderate-sized insulator all of the advantages of the different styles heretofore in use.

Having thus described my invention, what I desire to secure by Letters Patent is—

1. A glass insulator having formed within its interior a screw-thread, D, recess C', shield E, and recess H, all substantially as described, and for the purpose set forth.

2. A glass insulator, having formed within its interior a screw-thread, D, shield E, and recess H, in combination with the screw-peg P, all substantially as described, and for the purpose set forth.

SAMUEL OAKMAN.

Witnesses:

FRANK G. PARKER,  
WILLIAM EDSON.

Patent for petticoat insulator.

13 Nov 1883

(Courtesy of Mr. N. R. Woodward)

(No Model.)

S. OAKMAN.

TELEGRAPH INSULATOR.

No. 288,360.

Patented Nov. 13, 1883.



Fig. 1.

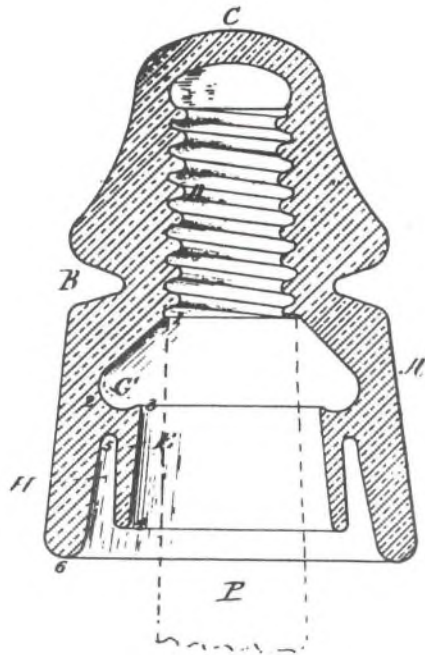

Fig. 2.

WITNESSES

*Frank G. Parker*  
*William Eason*

INVENTOR

*Samuel Oakman*



# UNITED STATES PATENT OFFICE.

SAMUEL OAKMAN, OF MELROSE, MASSACHUSETTS.

## DESIGN FOR AN INSULATOR.

SPECIFICATION forming part of Design No. 14,674, dated February 12, 1884.

Application filed November 2, 1883. Term of patent 7 years.

*To all whom it may concern:*

Be it known that I, SAMUEL OAKMAN, a citizen of the United States, residing at Melrose, in the county of Middlesex and State of Massachusetts, have invented and produced a new and original Design for Insulators, of which the following is a specification.

The drawing represents a perspective view of my design in elevation.

Heretofore insulators have been made which presented, when viewed in elevation, an irregular and complicated form not pleasing to the eye.

My design consists in having the insulator

shaped so as to be a regular paraboloid, or so near to this form as to strike the eye as such. This regular paraboloidal surface is interrupted by a single equatorial groove, as shown in the drawing.

I claim—

The design for an insulator herein shown and described, the body having the shape or configurations of the paraboloid traversed by an equatorial groove.

SAMUEL OAKMAN.

Witnesses:

HELEN M. FEEGAN,  
WILLIAM EDSON.

Patent for beehive design insulator.  
12 Feb 1884  
(Courtesy of Mr. N. R. Woodward and Elton Gish)



DESIGN.  
S. OAKMAN.  
INSULATOR.

No. 14,674.

Patented Feb. 12, 1884.



*Witnessed*  
*John H. Sugan*  
*William Edsord*

*Inventor*  
*Samuel Oakman*



TRADE-MARK.  
HEMINGRAY GLASS CO.  
ELECTRIC APPARATUS AND SUPPLIES.  
APPLICATION FILED FEB. 8, 1910.

78,096.

Registered May 31, 1910.

**REPUBLISHED**

Under Sec. 12 (c) 1946 Act 1-13-48

*Owens Illinois Glass Co.,  
Toledo, Ohio.*

AFFIDAVIT SEC. 8  
ACCEPTED

AFFIDAVIT SEC. 15  
RECEIVED 3-10-53

**HEMINGRAY**

PROPRIETOR  
*Hemingray Glass Co.*

By *Chas. A. Davis*  
Attorney

HEMINGRAY trademark registrations.  
Various dates  
(Courtesy of Mr. N. R. Woodward)

**THIRD RENEWAL**

*Quincy Illinois  
Inc.  
Toledo Ohio*

*La. Cl. 9, 17*

78,006. ELECTRIC APPARATUS AND SUPPLIES. Registered May 31, 1910. HEMINGRAY GLASS CO., Muncie, Ind., and Covington, Ky. Renewed May 31, 1930, to Hemingray Glass Company, Muncie, Ind., a Corporation of Kentucky.

78,006. HEMINGRAY. Registered May 31, 1910. Hemingray Glass Co., Muncie, Ind., and Covington, Ky. Re-renewed May 31, 1930, to American Structural Products Company, Toledo, Ohio, a corporation of Ohio. ELECTRIC, TELEGRAPH, TELEPHONE, CABLE,

STREET RAILWAY, AND FLOOR INSULATORS, AND BREAK-KNOBS OF GLASS. Class 21.

**UNITED STATES PATENT OFFICE,**

HEMINGRAY GLASS CO., OF MUNCIE, INDIANA, AND COVINGTON, KENTUCKY.

TRADE-MARK FOR ELECTRIC APPARATUS AND SUPPLIES.

78,006.

Statement and Declaration. Registered May 31, 1910.

Application filed February 8, 1910. Serial No. 47,650.

**STATEMENT.**

*To all whom it may concern:*

Be it known that HEMINGRAY GLASS CO., a corporation duly organized under the laws of the State of Kentucky, and located and doing business at Muncie, county of Delaware, State of Indiana, and at No. 2 Madison avenue, in the city of Covington, county of Kenton, and State of Kentucky, has adopted and used the trade-mark shown in the accompanying drawing, for electric, telegraph, telephone, cable, street-railway, and floor insulators, and break-knobs of glass, in Class No. 21, Electrical apparatus, machines, and supplies.

The trade-mark has been continuously used in the business of said corporation since 1870

The trade-mark is affixed to the goods by incorporating the same in molds and casting it directly upon the goods, and is illustrated upon labels or masters bearing representations of the articles.

HEMINGRAY GLASS CO.,  
By DANIEL C. HEMINGRAY,  
*Secretary.*

**DECLARATION.**

State of Kentucky, county of Kenton ss:

DANIEL C. HEMINGRAY, being duly sworn deposes and says that he is secretary of the corporation, the applicant named in the foregoing statement; that he believes the foregoing statement is true; that he believes said corporation is the owner of the trade mark sought to be registered; that no other person, firm, corporation or association, to the best of his knowledge and belief, has the right to use said trade mark in the United States, either in the identical form or in any such near resemblance thereto as might be calculated to deceive; that said trade mark is used by said corporation in commerce among the several States of the

United States; that the description and drawing presented truly represent the trade mark sought to be registered; that the fac-similes show the mark as actually used upon the goods; and that the mark has been in actual use as a trade mark of the applicant for ten years next preceding the passage of the act of February 20, 1905, and that to the best of his knowledge and belief, such use has been exclusive.

DANIEL C. HEMINGRAY.

Subscribed and sworn to before, a notary public, this 2nd day of February, 1910.

[L. S.] FRANK R. EVANS.



Registered Aug. 22, 1939

Trade-Mark 370,320

CANCELLED  
SECTION 8

REPUBLISHED

Under Sec. 12 (c) 1945 Act 2-24/48

## UNITED STATES PATENT OFFICE

Owens-Illinois Glass Company, Toledo, Ohio

Act of February 20, 1905

Application April 17, 1939, Serial No. 418,359

# LOWEX

### STATEMENT

*To the Commissioner of Patents:*

Owens-Illinois Glass Company, a corporation duly organized under the laws of the State of Ohio and having its principal place of business in the Ohio Building, Toledo, Ohio, has adopted and used the trade-mark shown in the accompanying drawing, for ELECTRICAL INSULATORS, in Class 21, Electrical apparatus, machines, and supplies, and presents herewith five specimens showing the trade-mark as actually used by applicant upon the goods, and requests that the same be registered in the United States Patent Office in accordance with the act of February 20, 1905.

The trade-mark was first used on or about March 14, 1939, and has been continuously used and applied to said goods in applicant's business since said date.

The trade-mark is applied to the goods by cutting the mark in the molds in which the articles are molded and also by printing the mark on the containers in which the goods are packed and shipped.

Said Owens-Illinois Glass Company hereby appoints Rule & Hoge (registry No. 14,124), P. O. Box 1035, Toledo, Ohio (a firm composed of John F. Rule and J. Ralph Hoge), its attorneys, to prosecute this application for registration, with full power of substitution and revocation, to make alterations and amendments therein, to receive the certificate and to transact all business in the Patent Office connected therewith.

OWENS-ILLINOIS GLASS COMPANY,  
By JOHN H. McNERNEY,  
*Secretary and Assistant Treasurer.*

LOWEX trademark registrations.  
Various dates  
(Courtesy of Mr. N. R. Woodward)

## FURNACE NOTES

Following our tour of the Muncie factory by Ruth Crawford in 1981, we were shown into the first floor of the office building which has "HEMINGRAY GLASS COMPANY" written at the top. Along with the large map we were given, there were 18 furnace photos scattered on the floor. Ruth said that I could take them, but they didn't look very interesting to me and I didn't want them. But Ruth picked them all up and insisted that I take them. I have almost thrown them out several times over the years because I really didn't know what they were as far as their value to Hemingray history. My natural pack rat instincts are what saved them for posterity.

Each photo measures approximately 4" by 5" except for number 7, which is 8" by 10". The photos are interior shots of both "A" and "B" furnaces taken at various times as repairs were made. On the back of number 7 is written, "Shadow Wall Setting. 'B' Furnace, Rebuild '1949', Herman Holm Specifications". (Not to be confused with Minot K. Holmes, Herman Holm was listed in a 1945 Muncie city directory as a supervisor at O-I.) The other photos contain dates put on by Ruth Crawford. The letters and numbers on some of the photos are on the furnace walls themselves, not on the photo.

Even as I began this book, I still didn't realize how valuable these photos were. Then, after reading Fred Padgett's Dreams of Glass, The Story of William McLaughlin and His Glass Company, I contacted him to find out more about furnaces. He was kind enough to send a drawing along with the Minot K. Holmes furnace patent, and a detailed eight-page letter explaining my furnace photos and the glassmaking process with the old-style tank furnace. So the photos, combined with Fred's explanation, really gives the reader an excellent idea of what the furnaces looked like on the inside, how they worked, and how the glass was melted, refined, and readied for the molds.

I thank Fred very much, along with Don McLaughlin, son of glass-maker William McLaughlin, who also examined the photos and gave insight into what they meant. Concerning the patent and photos Fred wrote, "I decided...to locate the patent that pertains to the furnace whose picture you have. I...feel that this information puts you light years ahead of anything that I've seen in print about glass furnace design, and trust me when I say that the combination of those extremely valuable photos you received and the patent that relates directly to the photos is a combination we'll never see again in all of the history, written and yet to be written, of the making of glass objects in a mass production atmosphere."

Shortly after I completed this section of the furnace data, Bob Stahr was able to visit Muncie, and he took photos of the exterior of both "A" and "B" furnaces. He generously allowed me to use several of these beautiful photos for my book. When I saw the photos, they were exactly as I remembered it when I was there, complete with metal stairs and catwalk.



A few weeks later Bob was able to return and photograph the interior of "B" furnace! Again, he graciously allowed me to use several of these photos in my book. It is interesting to see how very much his photos resemble the ones given to me by Ruth Crawford.

Bob was able to measure the interior of "B" furnace, which came to approximately 19' by 42', the ceiling at the highest point reaching 9½' tall, down to 6'8" at the lowest point. The refining chamber has a 4' high wall at its lowest point and has a 12'8" radius (it is semi-circular).

These historical photos are truly priceless. Although these furnaces were rebuilt yearly, it was at these locations that the glass was melted that produced almost every Hemingray product from the late 1880s until they sold out in 1933, and Owens-Illinois continued to use them until they closed down in 1972. If you have a Hemingray insulator, chances are very good that it came from these furnace locations.

To some readers it might seem as though I am going into way too much detail about the furnaces. But Hemingray was a glassmaking business. I am assuming that anyone interested enough in Hemingray to read this book might also want to know, not just that they made glassware, but also how it was made. As you can see, to most people the furnaces are not a pretty sight; they are musty, rusty, and crusty! But to me, this section is a highlight of my book. These photos will be even more valuable as time goes by, for in all probability, these wonderful old furnaces and buildings will be soon torn down.

As you continue in this section, you will first see the 18 furnace photos, numbered for easy reference (as are all of the furnace photos). Following these is Fred's letter, his drawing, then the Minot K. Holmes patent sent by Fred. After this, you will find Bob's exterior and interior furnace photos. You might want to compare the following explanation from Fred's wonderfully detailed letter with all of these photos as you go along.

Words alone don't seem adequate, but I thank Bob Stahr most sincerely for sharing his furnace photos with me. They truly add the finishing touch to my furnace section.

All furnace photos are of "B" furnace unless otherwise marked.  
(Photos courtesy of Ruth Crawford)

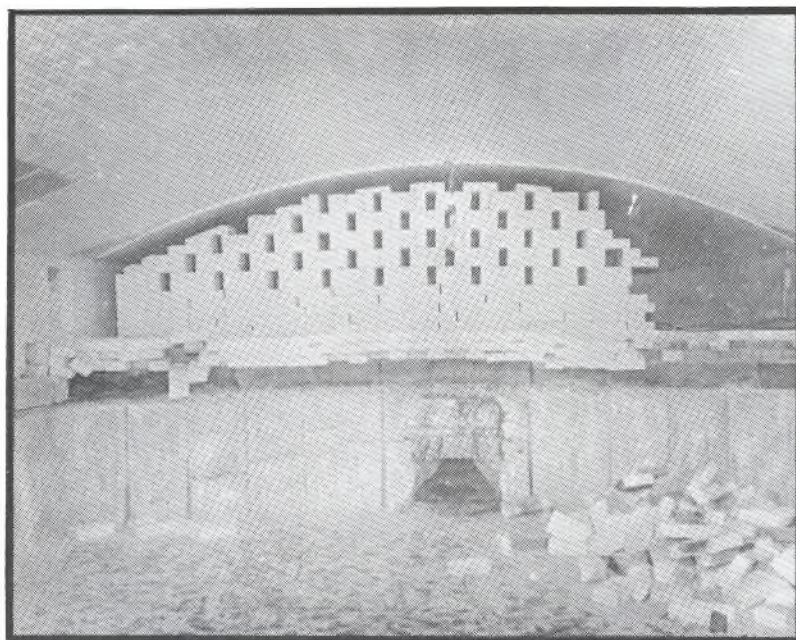

1. South end  
C. 1940

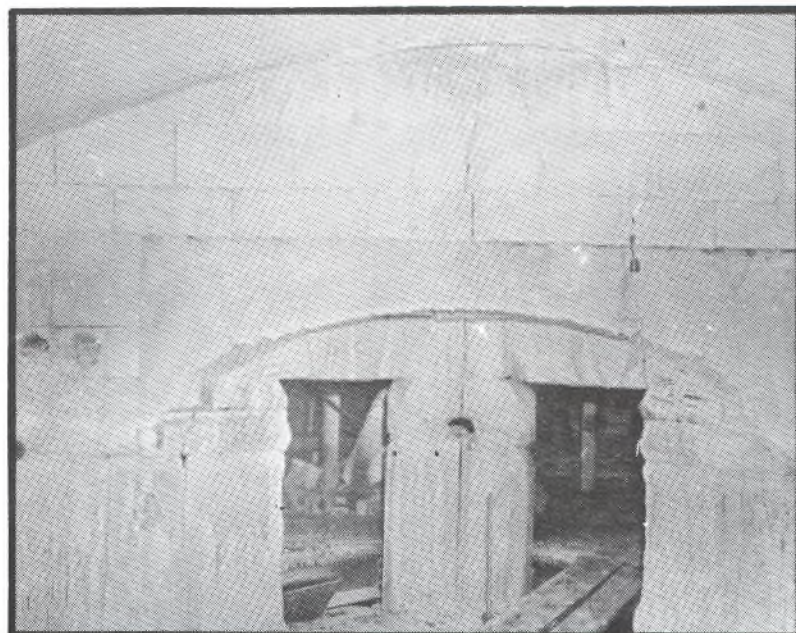

2. Possibly "A" furnace  
Date unknown





3. Close-up of south end  
C. 1940



4. West side looking south  
C. 1949

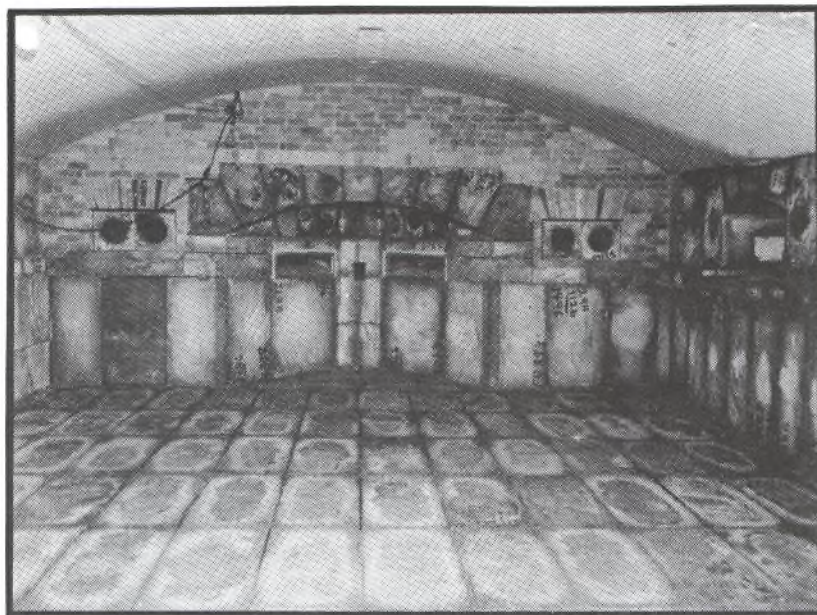

5. North end  
C. 1930

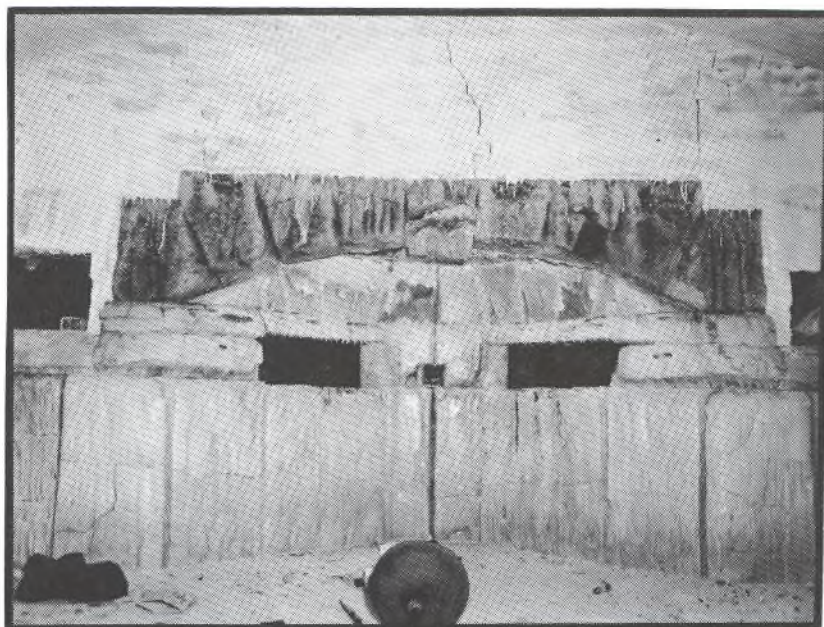

6. Possibly "A" furnace  
Date unknown



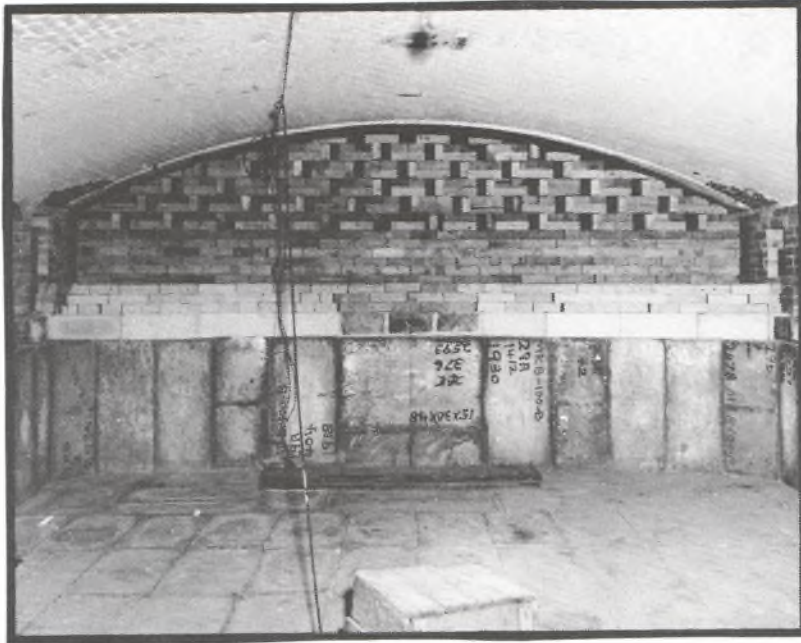

7. South end  
C. 1930

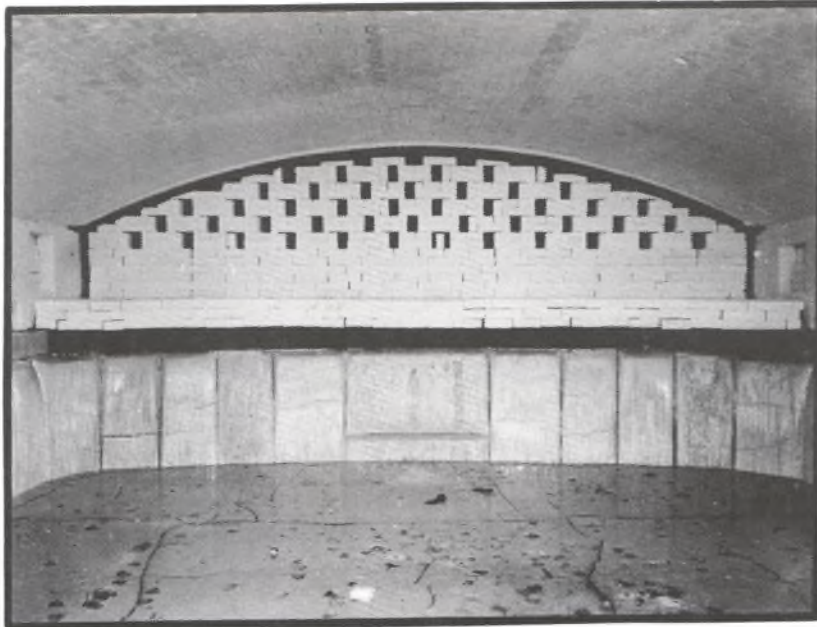

8. South end  
C. 1949

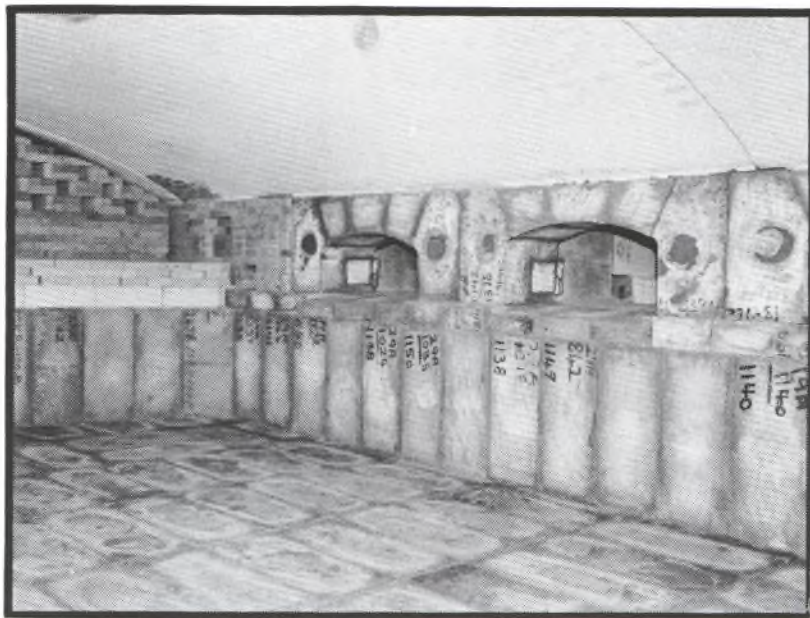

9. West side looking south  
C. 1930



10. Possibly "A" furnace, Ports 2 and 1  
Date unknown



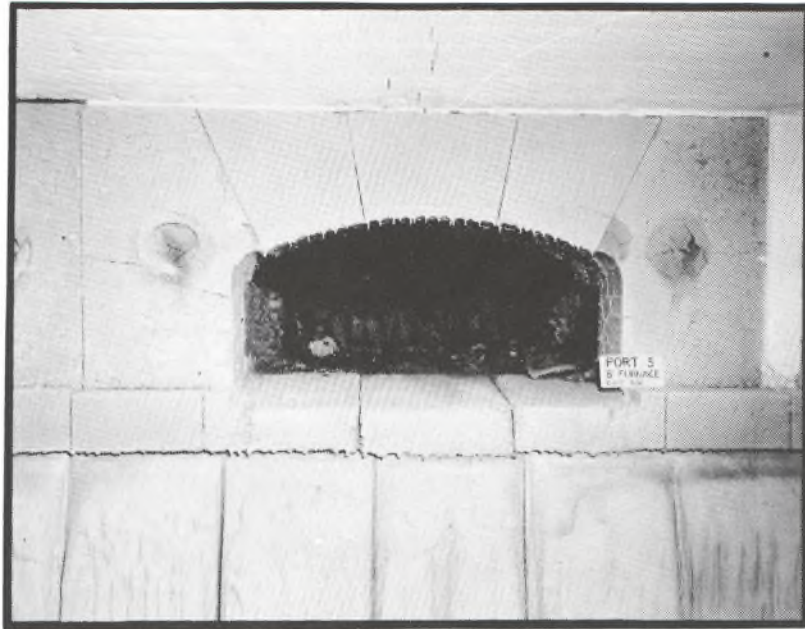

11. East side, Port 5  
C. 1940

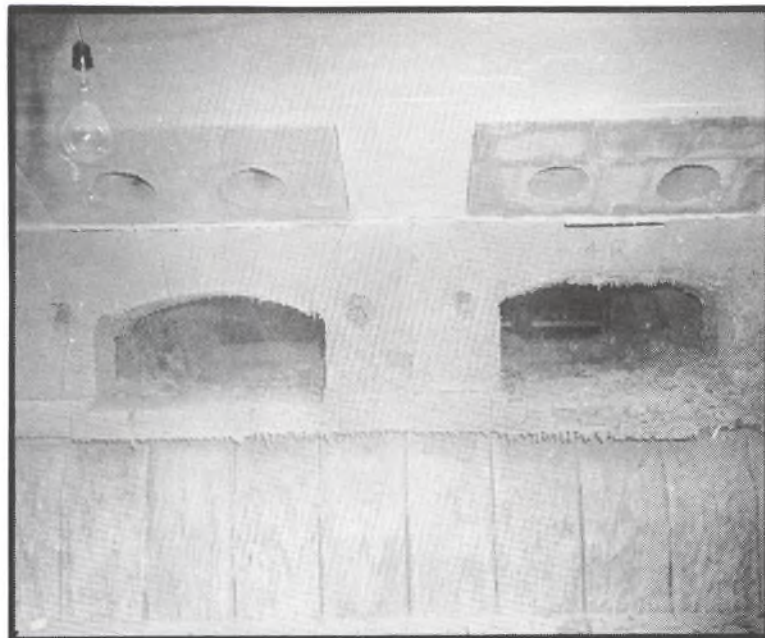

12. Possibly "A" furnace, Ports 5 and 4  
Date unknown

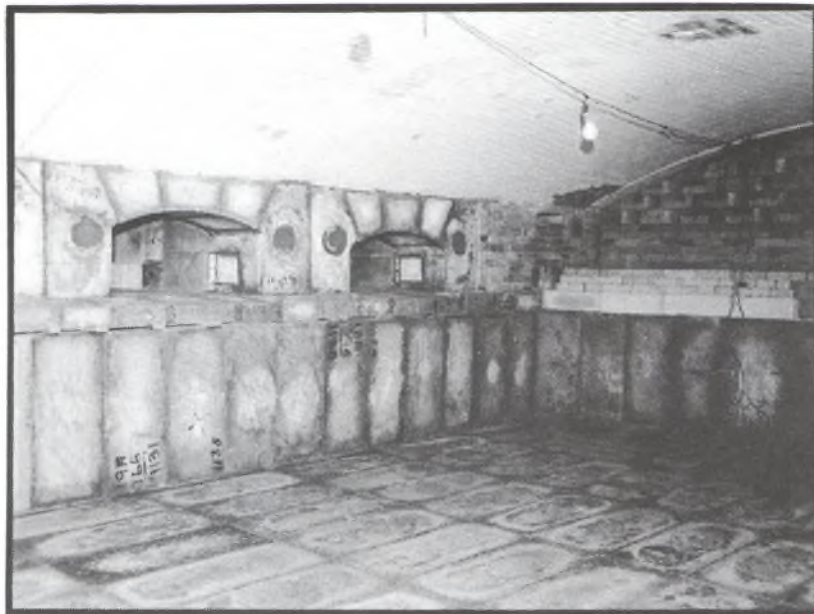

13. East side looking south, Ports 4 and 5  
C. 1930



14. East side, Port 1  
C. 1940



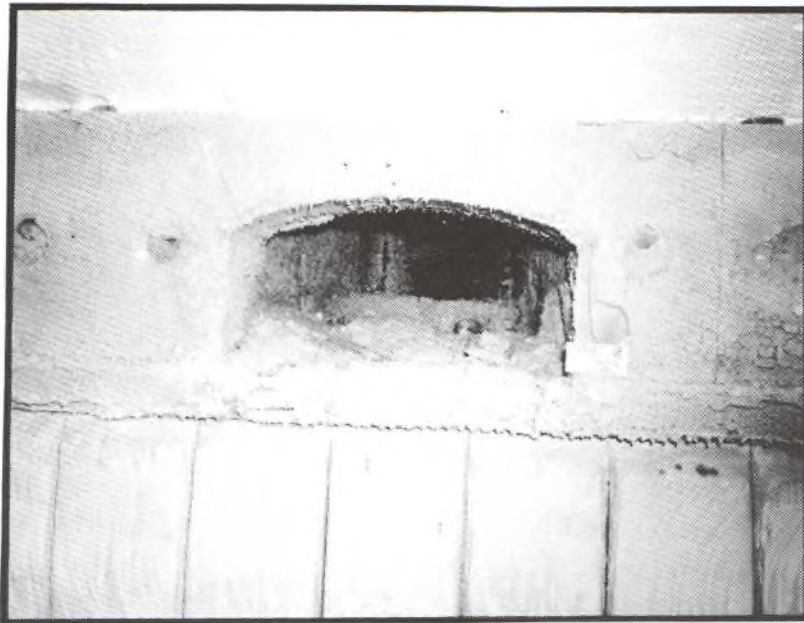

15. East side, Port 2  
C. 1940

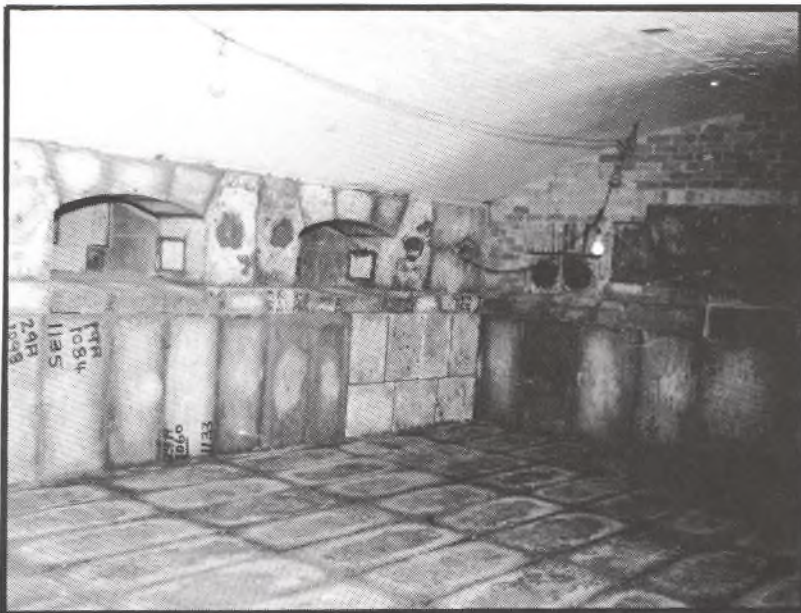

16. West side looking north  
C. 1930





Minot Holmes' patent reveals a great deal about the furnace photographs. Figure 1 of the patent drawings is a side view. Item 11 in this drawing is the area where the batch ingredients would be fed into the melting chamber. Figure 2 of the patent drawings is an excellent top view of these areas. Photographs #5 and #6 clearly picture the area where the ingredients would enter the melting chamber through the two rectangular openings in the center of the wall. Photo #5 shows a furnace in excellent condition, perhaps just rebuilt, while photo #6 shows a furnace in need of being rebuilt. The large furnace blocks that form the lower walls can clearly be seen to be covered with hardened glass in photo #6. Note in both photos #5 and #6 how the area that houses the rectangular holes is not flush with the wall, but is somewhat recessed. This is shown in both Figure 1 and Figure 2 patent drawings.

The two sets of two holes in photo #5 are burner ports in which part of the heat source was housed. If you look closely at photo #6, the rectangular blocks that housed the two burners each are missing, as are the two chutes through which the batch ingredients were introduced into the melting chamber.

The patent drawing Figure 1 also shows a side view cutaway of the roof or "arch" as it was called. Note the three archlike openings which appear over the melting chamber above the glass level. These correspond to the "ports" shown in photographs #4, #9, #16, #17, and #18. Don McLaughlin says that these openings had nothing to do with letting glass flow to the feeders, but were part of a reciprocating recirculating system that insured the even distribution of heat in all parts of the furnace thus maintaining consistent temperature throughout the process. Don identified the round holes on either side of these arched ports as being part of the complex system of burners in the furnace. The residue in photo #14 which is identified as "Port 1 East Side", probably is a gaseous carbon buildup rather than glass. Photos #13, #16, #17, and #18 show a furnace in good condition after a rebuild, while photos #10, #11, #12, #14, and #15 picture a furnace that has been heavily used and needs to be rebuilt. These could be different furnaces or the same furnace photographed at different times.

Patent drawing Figure 1 shows Item #14, which is the wall between the melting chamber or first chamber which oldtimers often referred to as a "pot", and the refining chamber which is shown in Figure 1 as Item #15. As the

ingredients in the batch fluxed or flowed together in the melting chamber it would begin to flow through an opening in the bottom of Item #14 (the wall) and eventually would fill the refining chamber shown as Item #15 in drawing Figure 1. By mixing glass in this manner bubbles and impurities settle out in the refining chamber allowing pure clean glass to rise to the top of the refining chamber where it is ready to be used. Item #14 in drawing Figure 1 can be seen as the wall with the hole in the middle at floor level in photos #1 and #3. These photos graphically illustrate the construction of the dividing wall between the melting and the refining chambers. Look at patent drawing Figure 2 and a better representation of the Item #14 is shown looking at it from above. What is missing in Minot Holmes' drawings is the checker brick or staggered brick structure that sits on top of the wall indentified as Item #14, which photo #1 shows clearly. Don McLaughlin commented that this checker brick wall would allow heat to pass through the openings and at the same time would absorb and hold heat in the bricks themselves, thus helping to maintain a constant temperature in both the melting and refining tanks.

This leaves one puzzle to be solved and that is where do photos #7 and #8 fit in with the Minot Holmes patent. Photos #7 and #8 correspond to the wall at the very end of the furnace in the refining chamber where the molten glass leaves the furnace and begins its journey to the feeders and molds. There is a checker brick wall here also because behind that checker brick are the tapered channels Holmes invented to allow glass to exit the furnace at the optimum working temperature. These can be seen as Items #18 in patent drawing Figure 2. Again, the checker brick wall would allow heat to pass through the openings and at the same time would absorb and hold heat working toward keeping the constant temperature at the tapered delivery channels that was being maintained in both the melting and refining chambers.

Looking closely at the arrangement of the checker brick in photos #7 and #8 it can be determined that these photos are of the final wall of the same furnace where the molten glass would be delivered from the furnace to the feeders.

There are major differences between the way the walls in photo #7 and photo #8 are constructed. Looking closely at #7, there is a row of large light-colored bricks resting on top of the tall bricks that form the lower portion of the wall. In the middle of this row are three dark bricks side by side. On top of this row are three rows of small light-colored bricks and in the middle of these three rows is a section of darker small bricks right above the three larger dark bricks. Would the three dark bricks at one



time have been an opening where glass flowed from the refining chamber either into the "dog house" and then on to the feeders and molds, or directly to the feeders and molds? If so, photo #7 is of a rebuilt furnace and perhaps those dark bricks were put there to temporarily support the checker brick structure above while preparations were being made to convert the delivery end to Minot Holmes' design. On the back side of photo #7 are written the dates 1904-1918. The date Minot Holmes' patent was granted is August 8, 1916. The timing would be right for this change to be made.

Photo #8 clearly shows hardened glass on the tall bricks that form the lower portion of the wall. There also is a thickness of approximately ten inches of hardened glass on the furnace floor, indicating that the furnace probably is going to be rebuilt. By comparing the lines in the center of the wall slightly above floor level, the depth of the hardened glass on the floor can be seen. The row of large light-colored bricks shown atop the tall blocks that form the lower wall in photo #7 have been removed completely in photo #8. The molten glass would rise to the top of the large blocks in the refining chamber and flow out of the furnace through the gap to the tapered channels which are behind the checker brick wall. Patent drawings Figure 1, 2, and 3, show different perspectives of this arrangement. From the tapered channels streams of molten glass would flow out of the outlet, be cut into pieces the proper size and be conveyed to the feeders and fed into the molds.

There does not appear in the photos or the Holmes patent any provision to allow glass left in the furnace to flow out of the furnace if this would be advantageous so that the furnace could be refurbished. Some early furnace designs included a valve or valves that could be opened to allow unwanted molten glass to flow from the furnace into a pit where it would harden and be reused after the furnace would be rebuilt. This process was often dangerous and caused fires that closed glass factories which were never to reopen. Because the large "tank" furnaces were run around the clock for ten to eleven months of the year, the brick would be in such bad shape that it would have to be replaced anyway, so hardened glass would be chipped out of the furnace with little worry about damaging any of the bricks.

Because Minot Holmes' patent really only dealt with delivery of molten glass from the outlet of the furnace, that is mostly what the furnace patent detail is about.

WHY MINOT K. HOLMES DESIGNED HIS FEEDER SYSTEM AND HAD IT PATENTED

A Top View of the Old-Style Tank Furnace

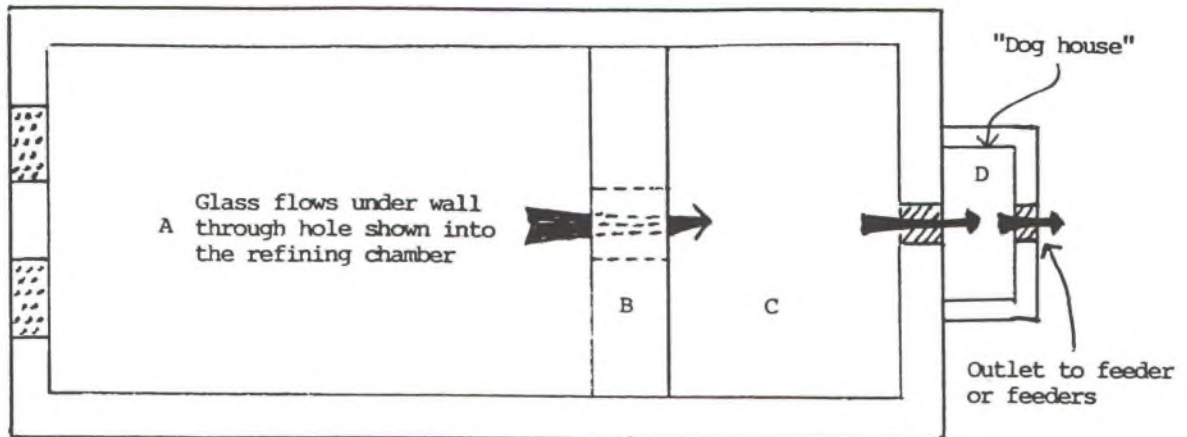

A. Melting tank where ingredients were added through openings in extreme left wall (shown like this: ) and melted by heat from several burners strategically placed.

B. Wall dividing melting tank and refining chamber--note hole shown as dotted line where molten glass flows from one chamber to the other.

C. Refining chamber where impurities and "blisters" (which are bubbles) settle out of the molten glass. The molten glass rises and flows out over the outlet, to the "dog house" (D), where it then is distributed to the conveyor and taken in cut, sized portions to the feeder and molds.

The problem with "tank"-style furnaces at this time was that glass was delivered in one continuous stream from the furnace "dog house" outlet, where it would be successively cut into proper-sized portions which would be conveyed to the feeders and fed to the molds where the desired glass objects would be made.

There were too many areas in the transition from refining chamber through the "dog house" where variations in glass temperature would occur and stagnant portions of glass would form, which were difficult and expensive to heat to a point where they would again flow smoothly through the furnace. The heat from the melting tank and refining chamber rarely was enough to heat the "dog house", so other heaters had to be added there at great expense.

Refer to Figure 2 of Mr. Holmes' patent. The top view shows the melting chamber, refining chamber, and tapered channels to the delivery openings, where the molten glass would flow out and be cut into slugs, and then be conveyed to the feeder and the molds.



By eliminating the "dog house", Mr. Holmes' system would allow one or more continuous streams of glass to flow from the furnace at the lowest possible temperature consistent with maintaining molten glass at its optimum working condition, thus solving the problem of stagnant pockets of unworkable glass forming and the expense of reheating them.

A key to Holmes' design is moving the tapered delivery channels back closer to the melting and refining chamber thus taking advantage of the tremendous even heat available in these areas to help heat the tapered channels.

For small special orders of color or special formulas they used day tanks and made enough for a day's use, often producing all of the batch by hand-blowing or hand-gather.

# UNITED STATES PATENT OFFICE.

MINOT K. HOLMES, OF MUNCIE, INDIANA, ASSIGNOR TO HEMINGRAY GLASS COMPANY,  
OF MUNCIE, INDIANA, A CORPORATION OF KENTUCKY.

## GLASS-FURNACE.

1,193,788.

Specification of Letters Patent.

Patented Aug. 8, 1916.

Application filed June 8, 1914. Serial No. 843,658.

### To all whom it may concern:

Be it known that I, MINOT K. HOLMES, a citizen of the United States, residing at Muncie, in the county of Delaware and State of Indiana, have invented a new and useful Glass-Furnace, of which the following is a specification.

It has heretofore been common to deliver from a glass melting furnace a continuous stream of glass and difficulty has been experienced in delivering the glass to the outlet opening of the furnace in a uniform condition such that successively cut off portions of the stream might be manipulated in the formation of commercial articles of glass-ware. In such prior furnaces it has been customary to form, at the delivery end of the furnace, a comparatively small extension which has been commonly called a "dog house". This extension has been in the form of a comparatively small chamber, the floor of which was elevated considerably above the floor of the main body of the refining end of the furnace and, while considerably wider than the delivered stream, was nevertheless quite narrow as compared with the furnace and of such form that the hot gases from the furnace could not well penetrate into the extension, and it has been necessary heretofore to supplementally heat the interior of the extension, and the glass therein, by means of gas or oil flames projected into the chamber through the wall thereof. While such a practice has been fairly satisfactory, difficulties have been experienced both because of the variations in the temperatures of the glass in different parts of the extension and also because of the deposit of carbon particles upon the surface of the glass resulting from incomplete combustion of the fuel. Variation in temperatures due to the fact that the chamber walls were comparatively distant from the outlet opening and, as the major flow took place along lines converging from the refining chamber toward the outlet opening, there would be stagnant portions of the glass in the chamber which could only be heated with great difficulty and much expenditure of fuel.

The object of my present invention is to produce a furnace especially designed for the delivery of one or more continuous streams of glass in the best possible condition for molding into articles and to main-

tain the stream or streams at the lowest possible temperatures consistent with proper working of glass after it is discharged from the furnace.

The accompanying drawings illustrate my invention.

Figure 1 is a longitudinal vertical section on line 1-1 of Fig. 2; Fig. 2 a plan on line 2-2 of Fig. 1; and Fig. 3 a transverse section on line 3-3 of Fig. 1.

In the drawings, 10 indicates the bed of a glass furnace, 11 the feed or receiving end, 12 the receiving end wall, 13 the arch, and 14 the refining bridge, all of usual form. At the delivery end of the refining chamber 15, however, I provide an elevated floor 16 which, however, is below the normal level of glass in the furnace by several inches. This floor 16 is extended from the main body of the furnace by a sufficient amount to accommodate machines which are to be served from the furnace and at its forward end is erected the delivery end wall 17, the arch 13 being carried clear to this wall. As many delivery openings may be provided as desired within the capacity of the furnace and in Fig. 2 I have indicated three of such delivery openings, that number being about the capacity of the furnace shown and upon the floor 16 I erect several platforms 16', 16', the tops of which rise slightly above the normal level of glass and the adjacent edges of which are slightly inclined and separated so as to form between their substantially vertical adjacent edges slightly tapered channels 18 which connect with openings 19 formed through the delivery end wall 17, the openings 19 having a vertical extent several times greater than the height of the platforms 16'.

Over the outer end of each opening 19 I place a flow block 20 which is conveniently semi-cylindrical and provided upon its inner vertical face with a semi-cylindrical channel 21 which registers with and completes the outer end of the opening 19 and is not very much larger than the delivery opening 22 which is formed in its lower wall. In its upper end the block 20 is provided with an opening 23 through which may be introduced a burner so that flame may be applied directly to the glass within the flow block after the delivery opening has been allowed to freeze up. Through the vertical wall of the block 20 is formed an inspection opening

Furnace patent.  
(Courtesy of Fred Padgett)



24 in which is normally placed a stopper or plug 25. Block 20 may be pointed into or to wall 17 in any desired manner and in practice it is advisable to also equip the lower end of this flow block with a metal valve 26 by means of which the effective opening of the delivery opening 22 may be varied.

The platforms 16' are so arranged as to cause the delivery of molten glass directly from the refining chamber through the channels 18 to the delivery openings 22 without the possibility of any material areas of stagnant glass close to the end walls of the furnace. The entire refining chamber lies so well in front of the delivery end of wall 17 and, as the arch 13 extends for a considerable distance beyond this refining chamber, the entire mass of glass in the refining chamber is of substantially uniform temperature and consistency and, as the arch 13 also extends over the entire length of the platforms 16', these platforms are also of the same temperature as the body of glass in the refining chamber and consequently each stream of glass in the channel 18 is flanked by walls which are of the same temperature as the glass and, therefore, produce no chilling effect upon the streams. As a consequence, the streams arrive at the outlet openings 22 in substantially the same condition and at the same temperature as the glass in the refining chamber and, while there is some chilling immediately adjacent the outlet opening yet nevertheless the hot gases, because of the height of the openings 19 in the delivery end wall, have free play upon the streams throughout their entire length and, as they are comparatively narrow, there is no difficulty in maintaining the desired uniformity in the inner stream throughout its entire length.

I claim as my invention:

1. A glass furnace comprising a main bed, a floor at the delivery end of the main bed elevated above the main bed and lying below

the normal level of glass, a delivery end wall erected at the delivery end of said elevated floor and having a delivery opening of material vertical extent therethrough, a flow block provided with a delivery chamber arranged to cover said opening, said flow block having a delivery opening formed through its bottom, and platforms erected upon said elevated floor with their upper faces above the normal glass level and laterally separated to form a channel registering with the opening in the delivery end of the wall.

2. A glass furnace comprising a main bed, a floor at the delivery end of the main bed elevated above the main bed and lying below the normal level of glass, a delivery end wall erected at the delivery end of said elevated floor and having a delivery opening of material vertical extent therethrough, a flow block provided with a delivery chamber arranged to cover said opening, said flow block having a delivery opening formed through its bottom, and platforms erected upon said elevated floor and laterally separated to form a channel registering with the opening in the delivery end of the wall.

3. A glass furnace comprising a main bed, a floor at the delivery end of the main bed elevated above the main bed and lying below the normal level of glass, a delivery end wall erected at the delivery end of said elevated floor and having a delivery opening of material vertical extent therethrough, and a flow block provided with a delivery chamber arranged to cover said opening, said flow block having a delivery opening formed through its bottom.

In witness whereof, I have hereunto set my hand at Muncie, Indiana, this third day of June, A. D. one thousand nine hundred and fourteen.

MINOT K. HOLMES.

Witnesses:

JAMES G. MENDENHALL,  
CHAS. E. HAWK.

Copies of this patent may be obtained for five cents each, by addressing the "Commissioner of Patents, Washington, D. C."

M. K. HOLMES.  
GLASS FURNACE.  
APPLICATION FILED JUNE 8, 1914.

1,193,788.

Patented Aug. 8, 1916.  
2 SHEETS—SHEET 1.

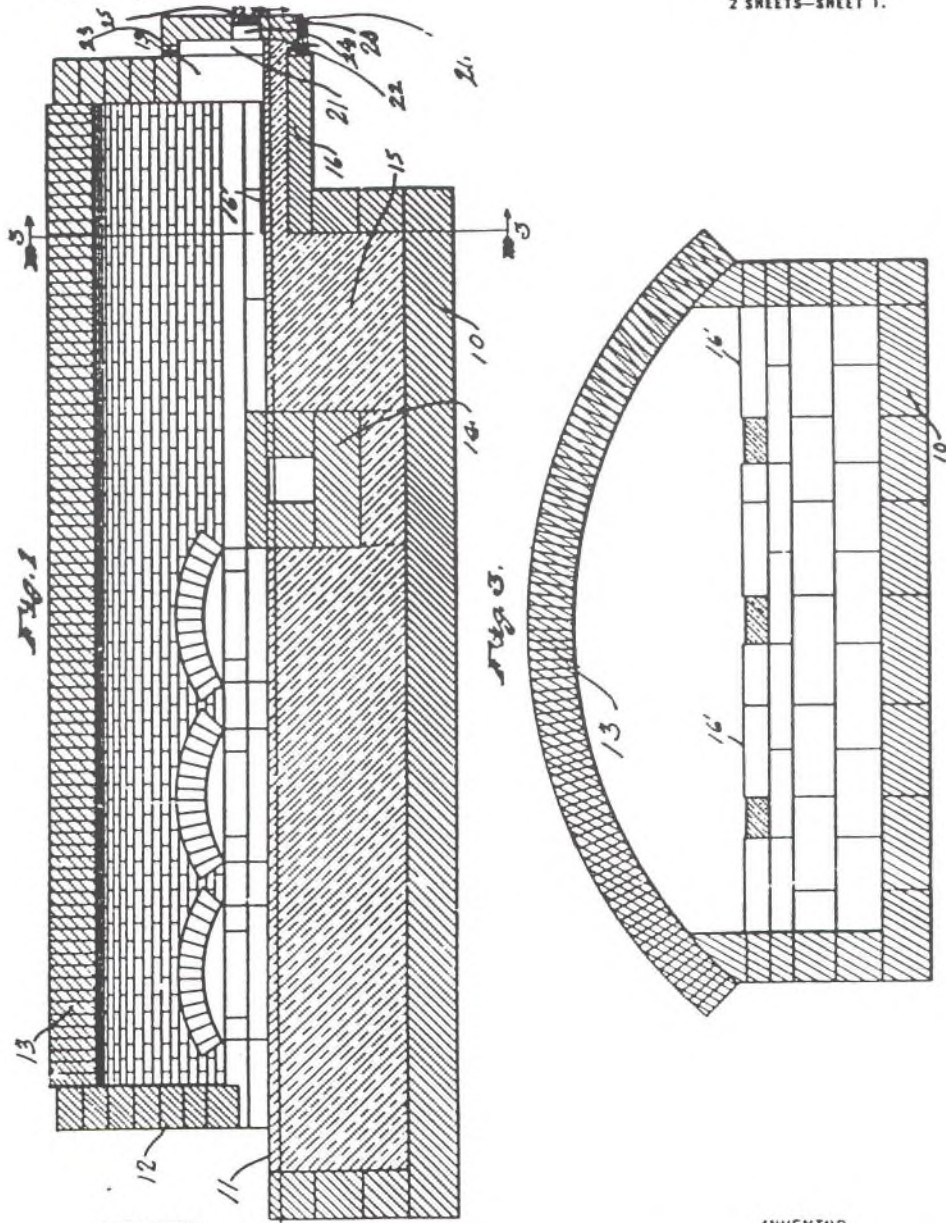

WITNESSES:

*Wm Baddock*  
*Josephine Gasper*

INVENTOR

*MIND K HOLMES.*

BY

*Hooder Schley*  
ATTORNEY



M. K. HOLMES.  
GLASS FURNACE.

APPLICATION FILED JUNE 8, 1914.

1,193,788.

Patented Aug. 8, 1916

2 SHEETS—SHEET 2.

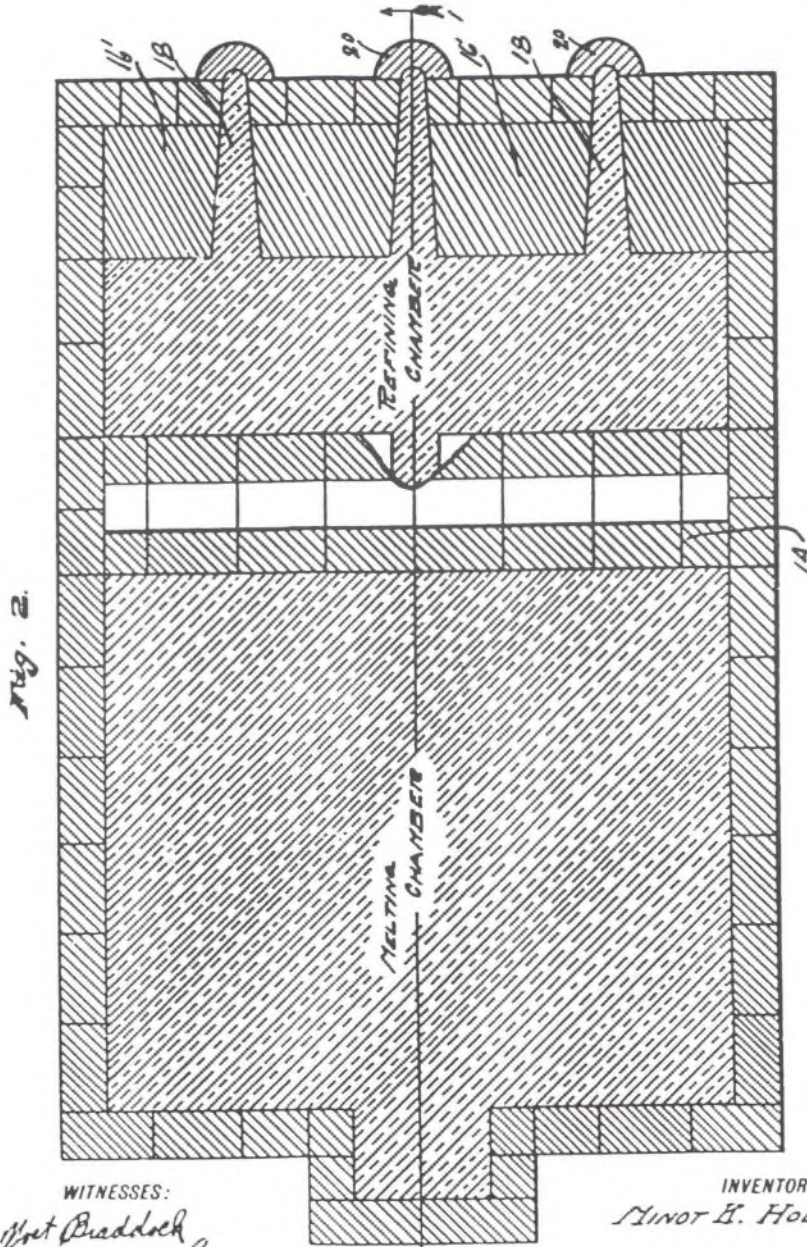

Fig. 2.

WITNESSES:

*Wm Braddock*  
*Josephine Gasper*

INVENTOR

*MINOT H. HOLMES*

BY

*Wood & Schley*  
ATTORNEY

Following are the furnace photos taken by Bob Stahr, and below are comments on some of the photos by Fred Padgett. The furnace photos are numbered consecutively to avoid confusion.

"Photos #19 and #20 look like the 'tapered channels' of Minot holmes' feeders. This would be the delivery area where the molten glass would leave the furnace on its way to the feeder, where it would be sized by weight and volume and fed to the molds.

"Photo #22 shows in the foreground what appears to be a part of the recirculator which moved the hot air and gasses through the melting tank, the refining chamber, and the delivery area. Note that the large pipe is heavily wrapped with asbestos insulation. Not only did this keep the heat out of the working area, but conversely it kept the heat in the recirculation system thus producing a cost savings for fuel.

"Photo #23 looks like another delivery area, only somewhat in disarray when compared to photos #19 and #20.

"Photo #24 looks like the outside of the outlet to another feeder as you have noted.

"Photos #32 and #33 are 'cleanout' doors at the bottom of the chimneys or stacks. The chimneys would build up with all kinds of ash and soot, and no doubt would have to be cleaned at the same time a furnace would go through its yearly rebuild. Stuff that fell to the bottom during the cleaning would be shoveled out of this door."



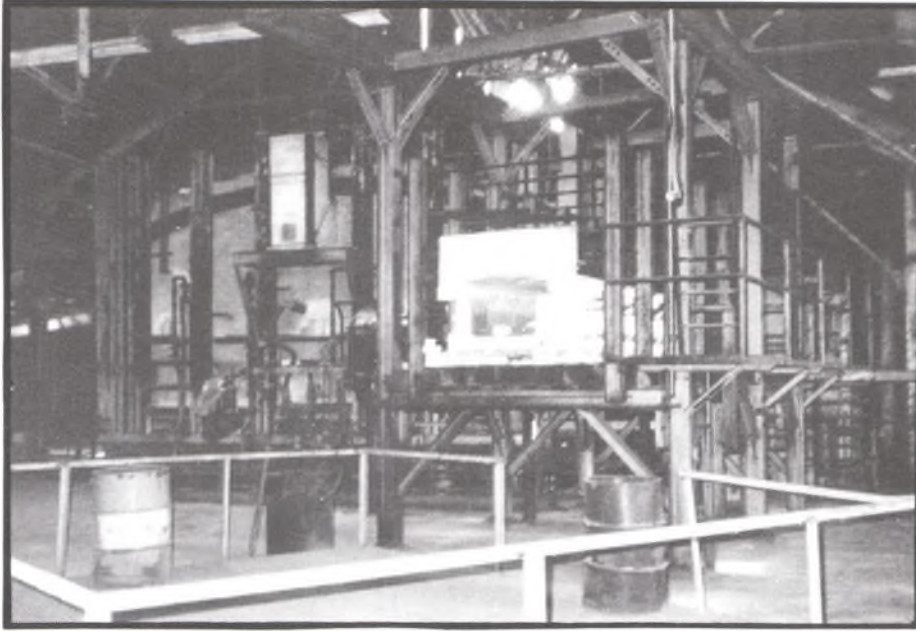

19. "A" furnace looking northwest. White area is close-up of feeder where glass came out to be formed by insulator (or other glass) presses. Furnace is brick structure at left.

Mar 1997

(Courtesy of Bob Stahr)

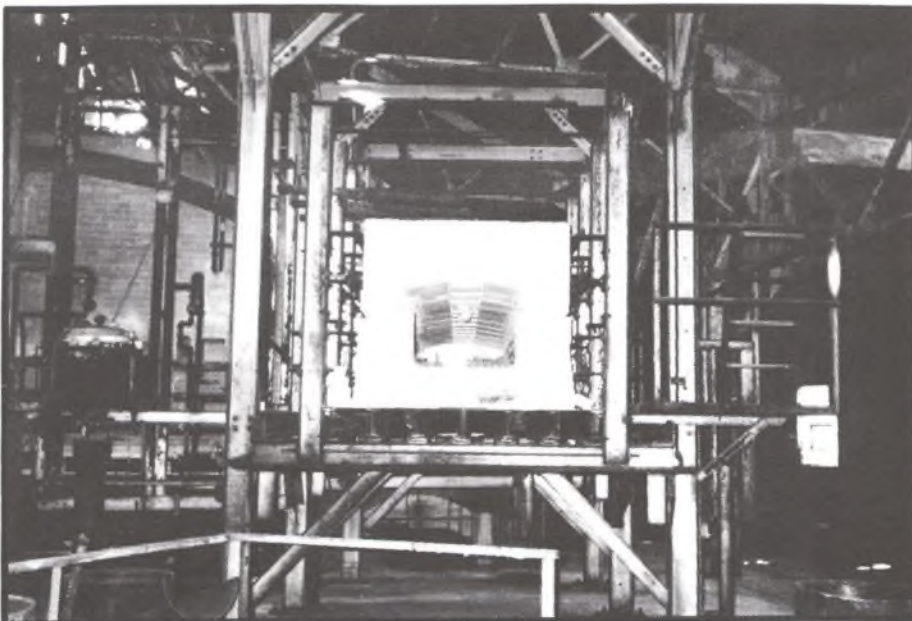

20. Close-up of feeder area. "A" furnace to left. Note metal stairs and catwalk to right.

Mar 1997

(Courtesy of Bob Stahr)

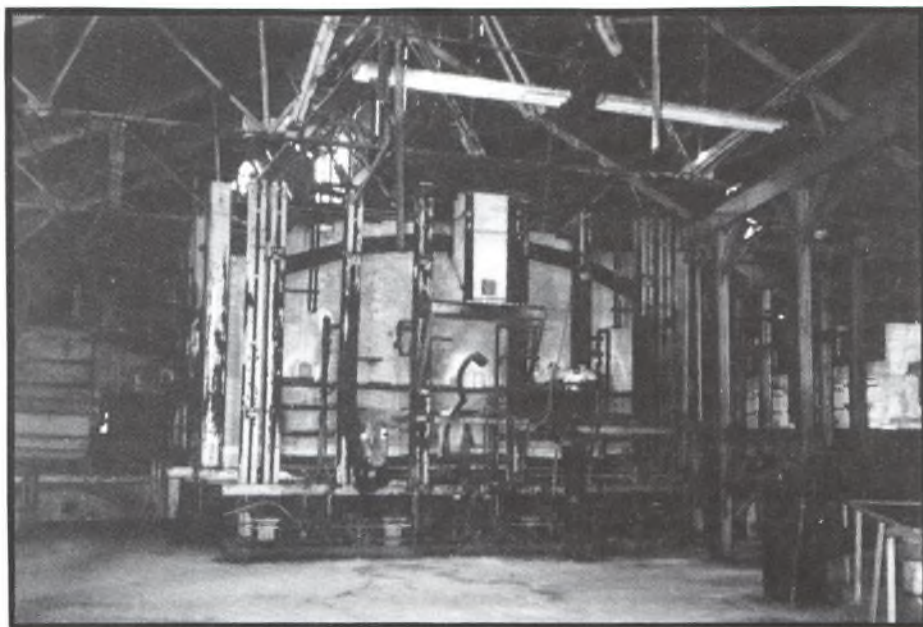

21. A beautiful shot of "A" furnace looking north.  
Mar 1997  
(Courtesy of Bob Stahr)

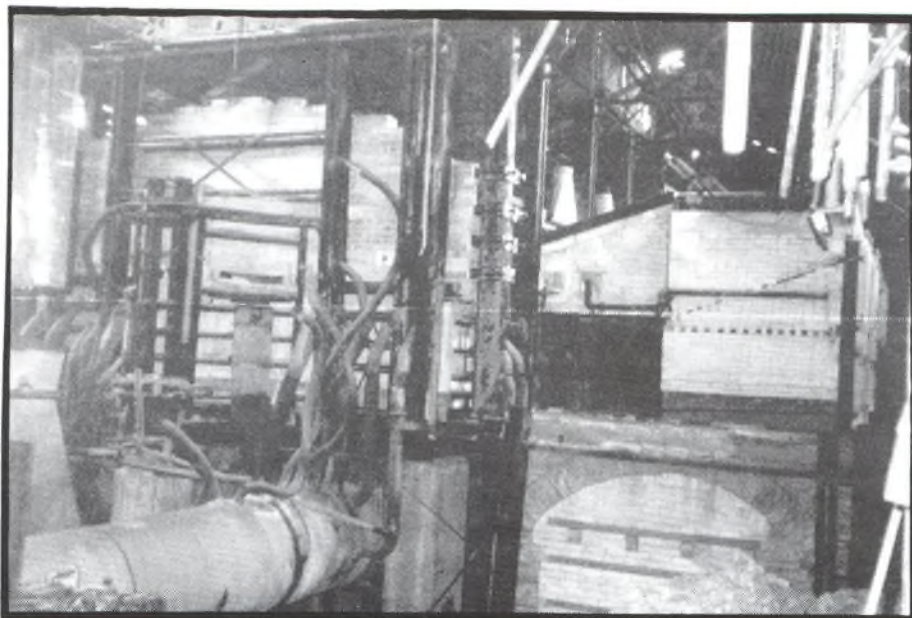

22. The back of "A" furnace looking southeast.  
Mar 1997  
(Courtesy of Bob Stahr)



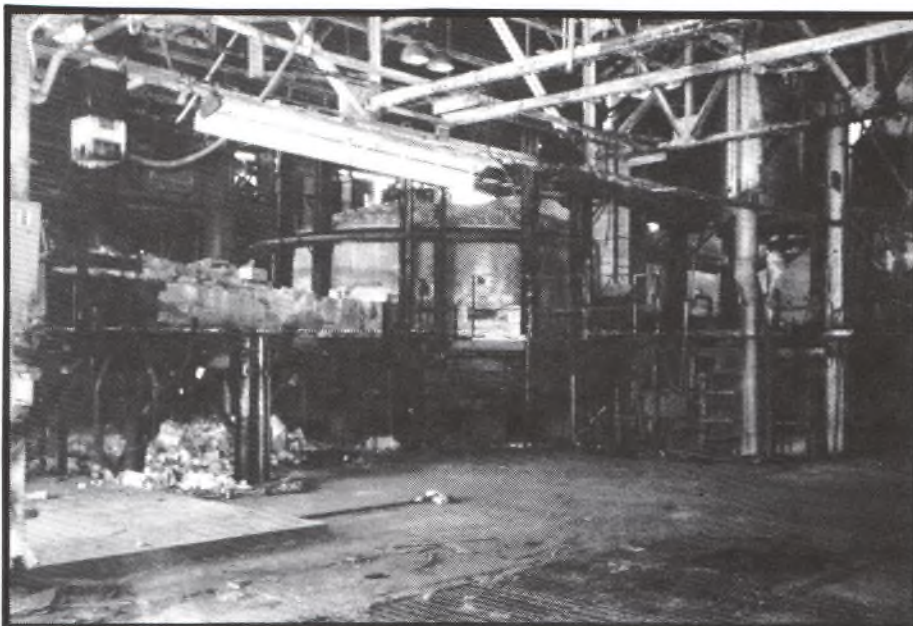

23. A gorgeous shot of "B" furnace looking northwest.  
Mar 1997  
(Courtesy of Bob Stahr)

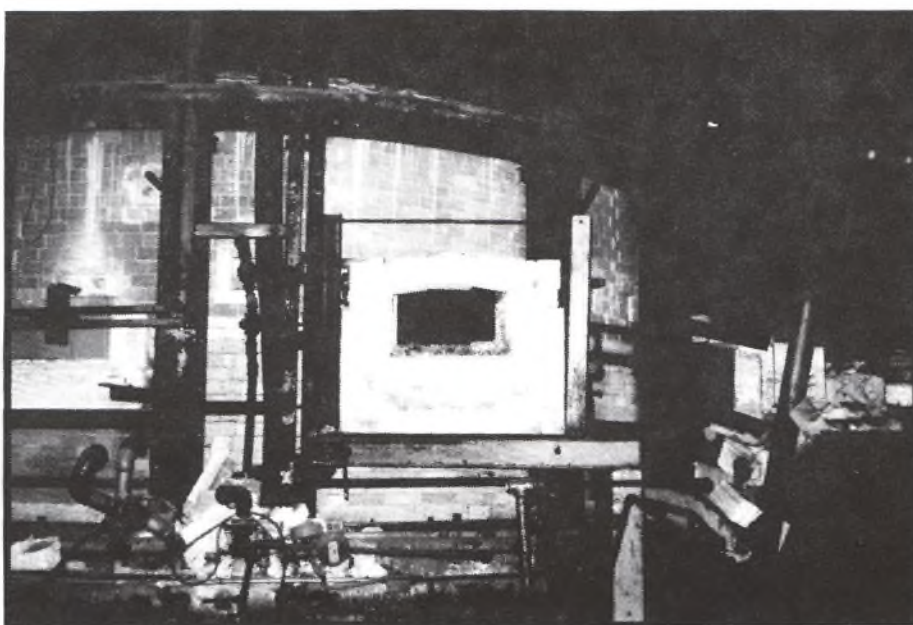

24. Close-up of "B" furnace showing feeder area looking east.  
Hardened glass can be seen at the bottom of opening.  
Mar 1997  
(Courtesy of Bob Stahr)

All interior photos in this section are of "B" furnace.

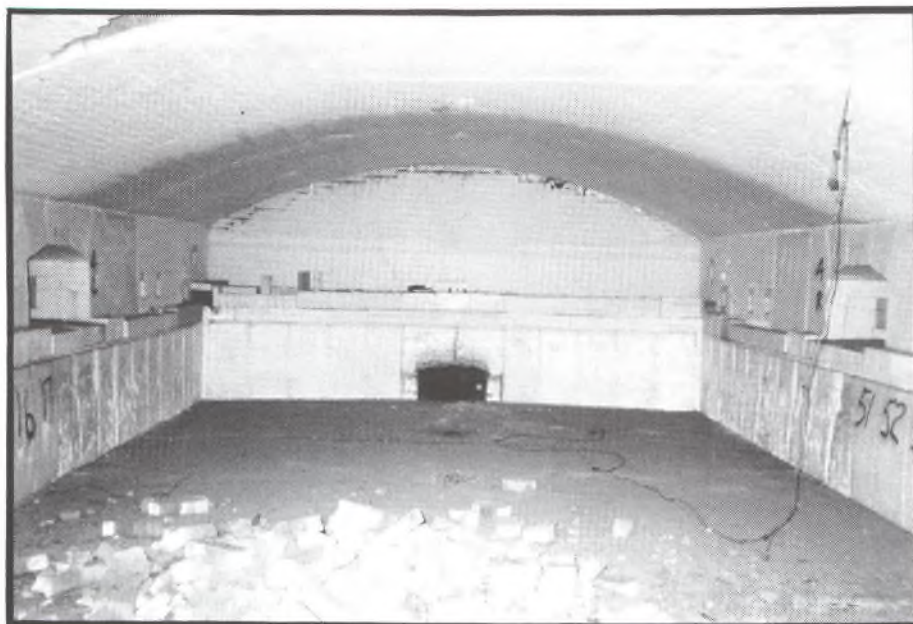

25. South end. (Compare to #1, #7, and #8)  
May 1997  
(Courtesy of Bob Stahr)

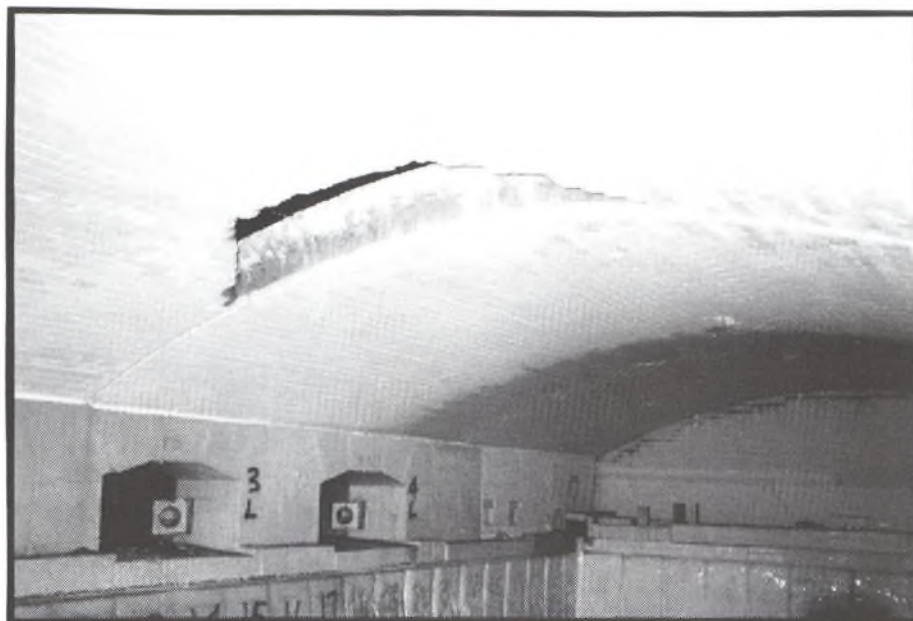

26. Looking south. Break in ceiling shows thickness  
of furnace roof.  
May 1997  
(Courtesy of Bob Stahr)





27. North end. (Compare to #5)  
May 1997  
(Courtesy of Bob Stahr)



28. West side looking north. (Compare to #16)  
May 1997  
(Courtesy of Bob Stahr)

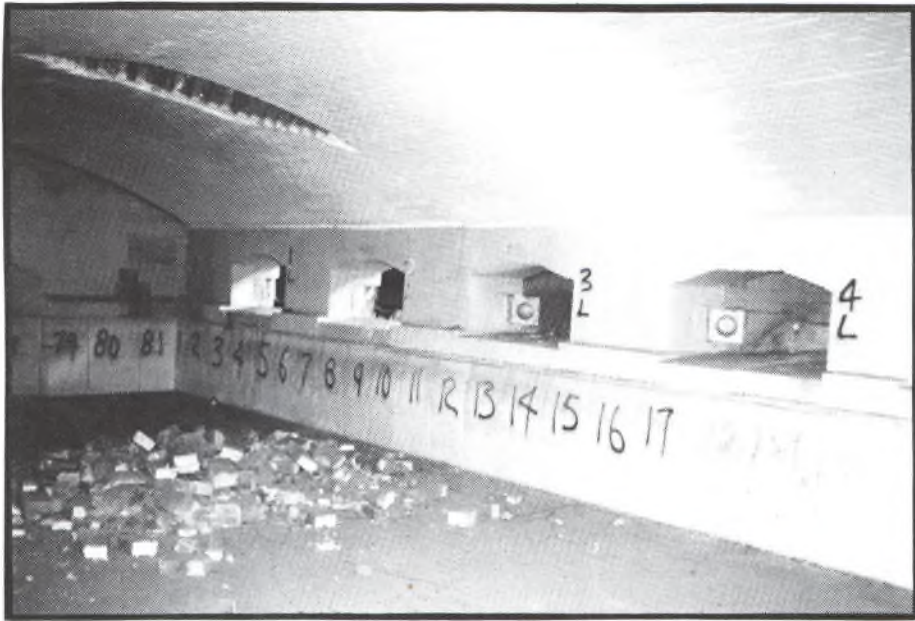

29. East side looking north. (Compare to #17)  
May 1997  
(Courtesy of Bob Stahr)



30. Semi-circular section (refining chamber). Lower left  
corner of photo shows where the glass went out into  
the feeders and to the molds.  
May 1997  
(Courtesy of Bob Stahr)



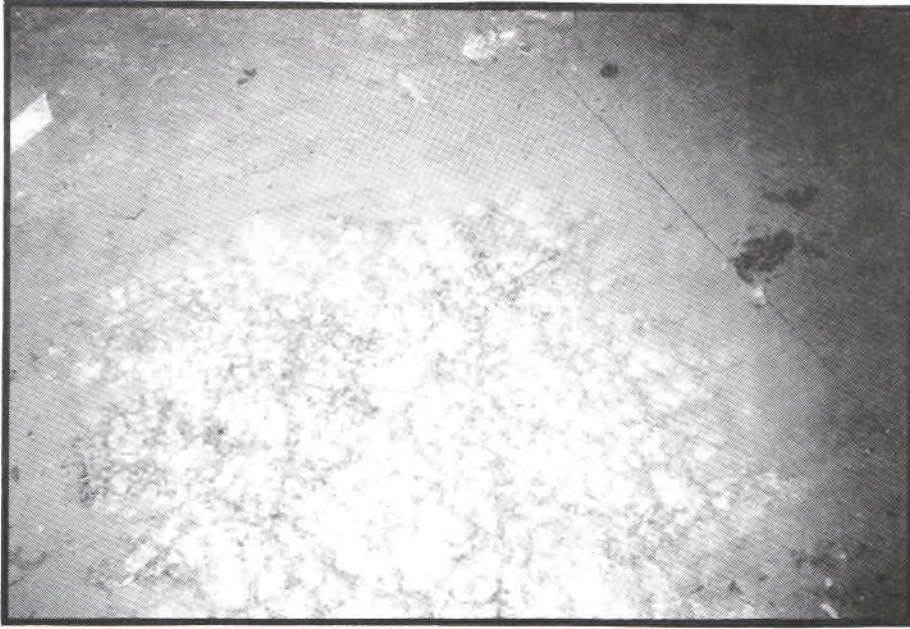

31. Furnace floor showing 3"-thick sheet of glass which cracked as a result of rapid cooling of the furnace. However, surface is "smooth as glass".

May 1997

(Courtesy of Bob Stahr)

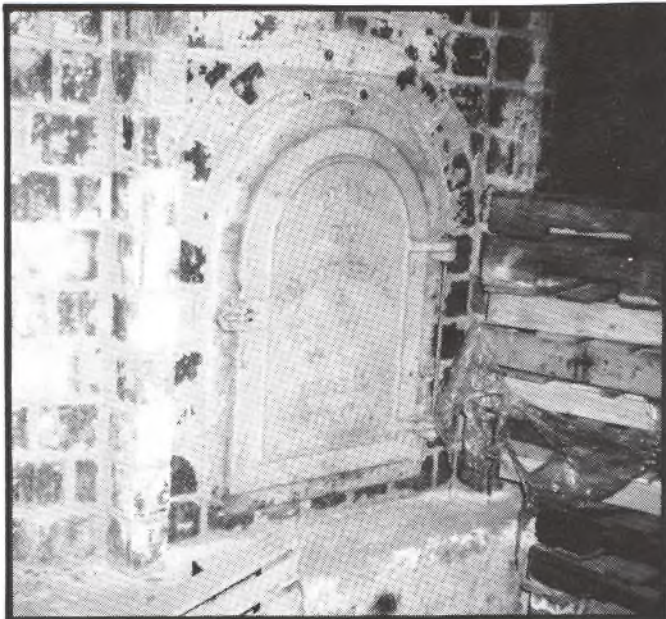

32. The iron cleanout door at the base of the chimney of "A" furnace. Embossing is as shown on next page. The "O" on "SONS" is missing.

Mar 1997

(Courtesy of Bob Stahr)

BUILT  
BY  
J.M. CUTSHALL  
&  
S NS

BRAZIL  
INDIANA

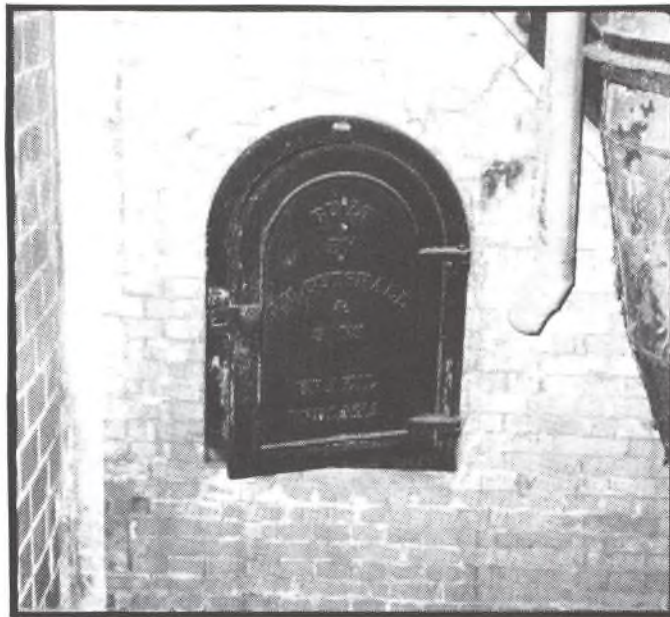

33. The iron door at the base of "B" furnace. The "O"  
is missing here also.

May 1997

(Courtesy of Bob Stahr)





to take out a patent. In February, 1869, he showed his drawing to a model-maker, and inquired, "What would be the cost of getting up models for the Patent Office?" (Shedlock, 2, 3.) He swears he made efforts at different times to induce different parties engaged in glass manufacture to use his invention. In June, 1869, he practically tested his process in Brookfield's shop, as is fully proven, successfully making a number of insulators. Brookfield was present and gave him an order for a machine, which was completed and delivered July 6, following. Afterward, the same year, he made Brookfield other machines. These are the facts in proof in behalf of the parties, respectively, and they are nowhere disputed. The question is whether Brooke, being first to conceive the invention, used reasonable diligence to adapt and perfect it for practical use. It is to be noted that he is not a glass manufacturer, and Hemingray is. Although he could (as he swears he did in 1869) make the machine, he could not himself readily use it to practically test his process. The best he could do, or all that he could reasonably be required to do, was to explain the process, in connection with the drawing of the machine, to those engaged in glass manufacture who would be likely to be interested by him to take it up and test it. This he did, and in about a year and a half from the date of his first conception of it he succeeded in introducing it into use in Brookfield's shop.

It is not shown by what means he could have had it used or tested any sooner than he did. There is nothing standing against him except the mere lapse of a comparatively short period of time during which another, better situated, perfected and used the invention. He accounts for his delay, and for no greater delay than that his own oath uncontradicted is sufficient. The reason alleged for not applying for a patent sooner, and thus conferring his invention upon the public, is that "he did not feel in circumstances to make application," and it is nowhere alleged or shown that he was. The screw-threaded insulator itself was patented. He could not use his process without making terms with the patentee, and he swears he saw him and tried to interest him in his invention. Hemingray employed the process as soon as he thought of it, because it was for his interest to do so, and he had nothing to prevent him.

But the question is not who used it first. That is not the only matter of importance in a controversy of this character. Precedence in its inception, the date of its origination, the time when sufficient proof shows it to have been so far developed by the aid of a drawing or model as to be actually communicated to the knowledge of others, who attest both their knowledge and the means of their knowledge, is quite as important. Brooke was unquestionably first as to that much of the act or work of invention, and the test of reasonable diligence afterward must not be applied with unreasonable rigor to cut him off. Although he did not at first perfect and prove his invention by use, or by embodying it in due form in an application for patent in this Office, I think he is shown by the proof to have been reasonably diligent in doing both. If I am correct in this opinion, his right to a patent should not be denied.

The decision of the Board is reversed and priority awarded to Brooke.



## JOB HISTORY--INSULATORS

Factory #86	Location Muncie	Machine Center 216
Furnace No. "A"	Shop No. A-3	Machine No. 103
Job No. 9	Description Insulator	No. Molds Operated 8
		Color Glass Flint

Date Started: 10-9-54			
Date Finished: 10-13-54			
Oper. Time 111.83	% Plant Effy. 81.6	Job Change	
Pcs. Shearcut 161065	% Job Effy. 79.9	Mold Change	.83
Pcs. Ideal 1500.81	% Oper. Effy. 93.2	Other Causes	.13
Pcs. Good 119850	% Speed Effy. 101.7	Total	7.21
Pcs. Bad 15498	% Off at Lehr 11.5		8.17
Standard Speed 22.00	Std. Hrs. Per 100 Pcs.		
Average Speed 22.37	Prev. Hi'st Avg. Speed		.0806
High Speed 22.37	Prev. Hi'st Speed		23.17
Avg. 24 Hr. Prod. 23970	Hi'st 24 Hr. Avg.		23.88
High 24 Hr. Prod. 27050	Hi'st 24 Hr. Prod.		31314
Lbs. Pulled 89360	Lbs. Packed		32350
Avg. Weight 8.81	Spec. Weight		65916
			8.50
	Std. Hrs. Burned		50.61

Major Defects: % to Offware

LEHR		FEEDER	
Type 7: Surf. Comb. No. 17	Type 5B-29	Orifice Size	
Speed 1 min, 20 sec. Loading	Plgr. Size 53-2582	Plgr. Cam	1-7/8"
Setting 1. 940; 2. 870; 3. 860; 4. 880; 5. 780	Plgr. Stroke 3"	Tube Height	1 1/2"
6. 780. Control Reading 970.	Diff: Hub 3"	Adj.	3"
	Bricks Out 200	Back	130
SPECIFICATIONS		Couple: Nose	2000
Screw No.	No. of Screws UP 20	Control: F	Auto. M 2005B
Gages Used and Requirements		Stack: F	1" M B Auto.
		Mach. Speed	1 1/2"
			22 in 60 sec.

BUCK AND CONVEYOR			
Type Buck Disc.	Time on Buck 22 sec.	Pcs on Buck	8
Wind on Buck Slides 1-3/4"	Wind Under Buck	Slide 1-3/4"	
Pcs. on Conv. g	Time on Conv. 60 sec.	Wind Under Conv.	yes

FORMING MACHINE		
Time of Gob in Mold 6-1/2 sec.	Plgr. Dwell 1/2 sec.	Head Pressure 23#
Wind on Ware 1/2"		
Wind Under Mach. Wind: None		

## MANUFACTURING COMMENTS

This Timing and Operating Data Taken: By C. Fair & H. Johns 10-13-54  
 no fire over conveyor at buck.  
 order Control 2-1/2 min.  
 personnel: Operator, Screw Out & Take Out.

Owens-Illinois job history.

13 Oct 1954

(Courtesy of Mike Sovereign and Glenn Drummond)

Below is a speech given in 1948 at an awards ceremony at Muncie by Carl Smith, Hemingray plant manager from 1939 to 1952. Data which I know to be incorrect I've put in brackets. Otherwise, I've copied it exactly as it was originally typed. You will notice that I borrowed heavily from this speech in writing portions of this book.

Again, we are happy to welcome you to a Muncie plant Service Award Ceremony. For some of you it is the first - many of you have participated the full seven times since these recognition services began. It is our sincerest hope that each of you derives from this affair the same large measure of satisfaction, pleasure and inspiration as do those sitting at this table.

It is highly significant, I think, that most of our distinguished guests sitting here with me will have travelled more than three-hundred-and-fifty miles and will have sacrificed their Saturday and a greater part of their Sunday to be with us tonight.

While the main theme of our meeting tonight quite properly is recognition of the fine service records of our fellow employees, we cannot forget that this is the year 1948 and that this year is the centennial anniversary of the founding of the business which this plant represents.

One hundred years! Eighteen hundred and forty-eight! Just to say those words at first makes little impression upon us. After all, it is just a date - one year of many. But let us turn back the pages of history for a few minutes.

I doubt that anyone here could tell me who was President of the U. S. in 1848. It was James K. Polk. Only ten men had preceded Polk in the Presidency. Just 59 years had passed since the adoption of the Constitution and the election of George Washington to his first term. Abraham Lincoln was then [thirty-seven] years old. Ulysses S. Grant was a young man of 26. Twenty-two presidents have succeeded Polk.

The war with Mexico was still raging the first of that year. Peace was finally declared in May 1848.

Indiana had been a state of the Union just 22 years - Illinois only 20 years. In fact, when 1848 opened, there were only 30 states in these United States - 18 were to come in later. The states west of the Mississippi totalled five - Iowa, Missouri, Arkansas, Louisiana, and Texas.

It was in 1848 that gold was first discovered in California at Sutter's Mill and the great migration westward in oxcart and mule-drawn covered-wagons did not really get under full headway until the next year. The "trek of the '49'ers" - one of the great mass migrations of history.



There were no railroads then crossing the great prairies and the Rocky Mountains. (There were none until 1869).

The first railroad in the United States constructed for the purpose of carrying passengers and general freight was only 18 years old. The Baltimore & Ohio Railroad had opened its first 13-mile stretch to traffic in 1830.

The telegraph had been born four years previously. The first message ever sent over a telegraph wire was sent by Samuel Morse in 1844. The first international telegraph cable was not laid until 1857 and the first telegraphic cable message did not span the ocean until August 1858, ten years after this business was founded. Communication with foreign countries was by ships up until 1858.

There were no typewriters in 1848. The first practical typewriter, the Remington, was placed on the market in 1874.

In 1875, a man was arrested in New York (and I quote from a great Boston newspaper of the day) "for exhibiting a device which he says will convey the human voice any distance over metallic wires so it will be heard by the listener at the other end". "And", stated the newspaper, "well-informed people know that it is impossible to transmit the human voice over wires and that, were it possible to do so, the thing would be of no practical value".

Alexander Graham Bell's patent on the telephone is dated March 1876 and the device was first exhibited to the public in that year.

To further emphasize the span of time which these 100 years we speak of represent, I want to mention a few other outstanding events of the many which make that period one of distinction:

Slavery was legal in 1848 - Slavery was officially abolished in 1865.

Alaska was owned by Russia, until we purchased it in 1867.

Electric lights were first used in the year 1880 in the City of New York.

The first practical automobile was tried out in 1893.

X-rays were discovered in 1895.

The first radio signal was sent in 1901 and the first radio-telegraphic message was sent in 1902. Speech broadcast came years later.

The Wright brothers made the first airplane flight in history in 1903.

The ladies were first granted the right by Federal law to vote in 1920.

And, let us not forget, all of the automatic glass machinery now used was invented in this period of which we speak.

During those years, our country was engaged in seven serious wars - the Mexican War, Civil War, Spanish-American War, the Philippine Insurrection, Boxer Rebellion, World War I, and lastly, the terrible struggle we have just witnessed - World War II.

In 1848, the City of Cincinnati had a population of a little over 90,000. Quoting from an authoritative history of Ohio - it was "the largest city of the West, north of New Orleans, and the fifth in population in the United States". Only New York, Boston, Philadelphia, and New Orleans were larger.

The Hemingray Glass business was founded in Cincinnati in 1848 by a partnership consisting of [an Ohio River steamboat operator named] Gray and Mr. Robert Hemingray. A small glass factory was built fronting on Hammond Street in that city, and operated under the name of Gray and Hemingray.

In [1861], the plant was moved across the river to Covington, Kentucky on the south bank of the Ohio River. Obviously, the location was chosen because in those days the river afforded the only practical, economical means for transporting coal and the other heavy materials used in the business, as well as low-cost distribution of its products. Barges were landed at its door.

In 1865, [Captain] Gray [retired] from active participation in the business and was succeeded by Mr. Samuel Hemingray, a brother of Robert. For about [three] years the business was conducted under the name of [R. Hemingray & Brother] until it was incorporated in [1868].

In the year 1883, the Ohio River Valley was visited by a great and destructive flood and the following year by a second one, not quite so severe. In common with most of the businesses and industries clustered upon its banks, the Hemingray plant sustained heavy losses as a result of what were the greatest rampages the Ohio had ever staged up to that time.

These circumstances, coupled with the ever-pressing desire for cheap fuel, caused the operators of the business, in the years 1887-1888, to purchase a site and move the



plant to Muncie where an apparently unlimited natural gas field had been opened two years previously.

By 1890, the Muncie plant had been completed and expanded to the point where it was able to take care of the trade, and operation of the Covington plant was abandoned.

In the summer of 1892, just when the factory had become well-established, the plant was destroyed by fire causing a temporary interruption. It was promptly rebuilt, however, and resumed operation in better condition and with a minimum of delay.

Very early in its history, the Hemingray Company had been called upon to manufacture glass insulators for the new telegraph industry and for years had done a small business in that line. Its other chief products when it became established in Muncie were a general line of hollow-ware, including lamps, lamp globes, tableware, fruit jars, etc.

Recognizing the importance of the rapid expansion of the telegraph and telephone business, which began in the late 90's, the company began to give its chief attention to the manufacture of insulators to serve that market.

In a comparatively short time, this item, in many types and varieties, became its sole product and this plant soon came to be known as the leading manufacturer of glass insulators in the entire world. Hemingray insulators carried the name of the company and the city not only over the whole American continent, but into practically every civilized country on the globe.

During the year 1920, at the end of World War I, the mechanization of the operation began under the far-seeing direction of Philip W. McAbee, the new president of the company, and the capable supervision of Minot K. Holmes. By 1925, this mechanization had increased production to a point where a considerable surplus furnace and equipment capacity existed.

In order to occupy this surplus capacity and continue to give employment to a maximum number of people, the company added to its products a line of glass bottles, in the marketing of which it was signally successful.

In 1933, the business was purchased by the Owens-Illinois Glass Company who took over active operation in June of that year. Its history and accomplishments since that time are as well-known to all of you as to me.

Ladies and gentlemen, that an industry has been able to exist and to grow through the storms and vicissitudes

of a century of time necessarily implies that certain good qualities and characteristics attach to it. The chief of these I say are these:

*First, it must render a needed service.*

*Second, its dealings with customer, employee, competitor and government must be fair and honorable.*

*Third, its product must be worthy and good.*

*Fourth, it must have working for it and with it a loyal group of intelligent employees who contribute the service needed to make the business successful.*

*I am satisfied, the fourth of these is the most important. Without the service of good employees, no business can carry on. And that, ladies and gentlemen, is why we are here tonight - to honor the service of those who have contributed so much to the business which furnishes us our livelihood.*

(Courtesy of Glenn Drummond, Ern Parkison, and Ball State Univ.,  
A. M. Bracken Library, Archives & Special Collections)

TRADE MARK  
STANDARD HEMINGRAY INSULATORS  
REGISTERED.



# THE BOOK ROOM



CD 194/195





## **A FEW NOTES ABOUT THE BOOK ROOM**

"The Book Room" lists all of the publications related to insulators currently available. Also given is the author's name and where these items can be ordered. Prices are not included as these could change over the years. If you see a publication you'd like to have, write to the address for that particular one to get further information.

This data has been generously provided by Carol McDougald from the "Reference Library" section of her magazine Crown Jewels of the Wire, for which I thank her so much.

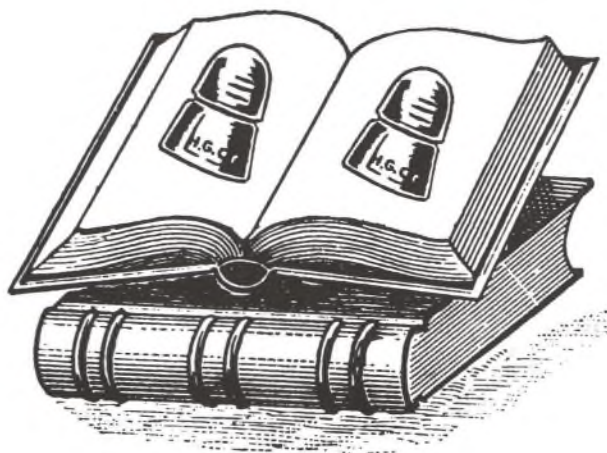

## INSULATOR AND GO-WITH PUBLICATIONS

### INSULATORS

- Albers, Marilyn. 14715 Oak Bend Drive, Houston, TX 77079  
Glass Insulators From Outside North America, 2nd Revision  
Albers/Woodward, 1993  
Price Guide for G.I.F.O.N.A., 2nd Revision  
Albers/Woodward, 1996  
Worldwide Porcelain Insulators  
Albers/Tod, 1982  
Worldwide Porcelain Insulators, 1986 Supplement  
Albers/Tod, 1986
- Burnet, Robert G. PO Box 40526, 5230 Dundas St. West, Etobicoke,  
Ontario M9B 6K8 Canada  
Canadian Railway Telegraph History  
Burnet, 1996
- Cranfill, Gary. 6353 Buckeye Lane, Granite Bay, CA 95746-9681  
The Glass Insulator-A Comprehensive Reference  
Cranfill, 1969  
Price list updated 1996
- Gish, Elton. PO Box 1317, Buna, TX 77612  
Multipart Porcelain Insulators  
Gish, 1988  
Fred M. Locke, A Biography  
Gish, 1994  
Value Guide for Unipart and Multipart Porcelain Insulators  
Gish, 1995  
Porcelain Insulators: Guide Book for Collectors  
Tod, 1988, reprint by Gish, 1995  
Insulator Patents, 1880-1960  
Tod, 1985, reprint by Gish, 1995
- Guthrie, Mike. 1209 W. Menlo, Fresno, CA 93711  
Fake, Altered and Repaired Insulators  
Guthrie, 1987
- Howard, Dan. 2940 S. E. 118th Avenue, Portland, OR 97266-1602  
Old Familiar Strains, bimonthly magazine
- Hyve, H. G. "Bea". 3269 N. Mountain View Dr., San Diego, CA 92116-1736  
The Hemingray Glass Company-A Most Colorful History  
Hyve, 1998
- Lauckner, Mark. Mayne Island, B. C., Canada V0N 2J0  
Spec-True, Collectible Glass Standard Color Reference  
Lauckner, 1991  
Canadian Railway Communications Insulators 1880-1920  
Lauckner, 1995
- McDougald, John & Carol. PO Box 1003, St. Charles, IL 60174  
Crown Jewels of the Wire, monthly magazine  
Annual October Subscriber/NIA Membership Directory  
INSULATORS-A History and Guide to North American Glass Pintype  
Insulators, Volumes 1 & 2  
McDougald, 1990  
Price Guide for the McDougald books  
McDougald, 1995  
What Are Insulators?, brochure  
McDougald/Hyve, 1997



- Padgett, Fred. PO Box 1122, Livermore, CA 94551  
Dreams of Glass-The Story of William McLaughlin and His Glass Company  
 Padgett, 1996
- Tucker, Mike. 508 W. Cherry, Cherokee, IA 51012  
In Search of Threadless-A Source Guide for Threadless Diggers  
 Tucker, 1990
- Walsh, C. D. 3289 Carriage Court, Clinton, WA 98236  
Most About Glass Insulators  
 Milholland, 1976
- Woodward, N. R. PO Box 171, Houston, TX 77001-0171  
Searching for Railway Telegraph Insulators  
 Neal, 1982 (England)  
Railway and Other Rare Insulators  
 Neal, 1987 (England)  
The Glass Insulator In America-1988 Report  
 Woodward, 1988

GO-WITHS

- Krupka, Rod. 2615 Echo Lane, Ortonville, MI 48462  
The Crown Point, lightning rods/balls newsletter, 4 issues annually  
The Complete Book of Lightning Rod Balls with Prices  
 Krupka/Bruner, 1995
- Linscott, Jacqueline. 3557 Nicklaus Drive, Titusville, FL 32780  
Blue Bell Paperweights, 1992 Revised  
 Linscott, 1992 and Addendum, Linscott, 1995

TRADE MARK  
 STANDARD **HEMINGRAY** INSULATORS  
 REGISTERED.





# FINAL NOTES



CD 122





## ACKNOWLEDGEMENTS AND THANKS

This book is the result of not just one author's work, but the combined efforts of many people from all over the United States. Belonging to the National Insulator Association has given me the opportunity to meet hundreds of friends I never would have known otherwise. As I prepared this book, I called on many of these friends for advice, help, and for photos and illustrations relating to the Hemingray Glass Company. I was constantly amazed at the overwhelming willingness to help me that each of these people showed. But then, I really shouldn't have been so surprised, because the insulator hobby is well known for the close relationships we form, creating a family-type feeling among our fellow enthusiasts. I was never once turned down by anyone of whom I made a request. Everyone was not only helpful, but anxious to provide what I needed.

This was also true of those people working at libraries and historical societies, and also at cemetery and vital record offices. I was met with total cooperation, and like my fellow hobbyists, they often went "the extra mile" for me.

I am attempting to mention everyone who was so kind. I've left no one out intentionally. There are four groups of names in this section, each in alphabetical order. First, my husband, followed by nine others along with a small photo of each one. These ten people really went above and beyond the call of duty, each of them helping in their own special way and in a different capacity. Following this list are other people and places; friends, institutions, or businesses that deserve special mention. These people and places helped with information, historical data, computer work, genealogy, or photocopies. Finally, there's a list of people who provided assistance in various areas, some simply by their encouragement and faith in my project. This book could not have been completed without the efforts of each of these generous individuals. No amount of thanks would be adequate, but I thank them all so much!

WES GORDON  
San Diego, California



First of all, I thank my totally supportive husband, Wes Gordon, who drove here and there getting photos screened, copies made at the print shop, listened to the typewriter for years, did housework while I typed, and gave me the encouragement I needed to start this project and continue with it. He will be 81 years old by the time this book comes out, so these efforts were not easy for him. But Wes worked every bit as hard on this book as I did.

TOMMY BURNETT  
San Diego, California



Special mention must be made of Tommy Burnett of Burnett Litho Negatives. Anyone who has written a book knows just how expensive it is to have photos and illustrations screened, PMT'd, enlarged or reduced. Many places charge over \$25 for each shot, and require a week's wait or longer. My book contains hundreds of photos and illustrations, and there is no way I could have included even one fourth of them if it weren't for Tommy. The majority of the time he would shoot several images for just \$10 or less, and a few times he wouldn't take any money at all. Plus, we could take the material home the same day. My thanks go to Tommy for his beautiful work, his kindness, and for his big generous heart.

GLENN DRUMMOND  
Notasulga, Alabama



Glenn has been helping me with Hemingway history for over 20 years. None of the articles I wrote could have been done without him, and certainly this book is the result of his generosity with his knowledge and material. His primary interest is the Cincinnati and Covington eras, and he has spent countless hours researching this phase of Hemingway history. He has always been extremely generous with his knowledge, as you can see from the many things he has contributed to this book, not to mention the information he has provided. Also, he took time to proofread my manuscript. I thank Glenn for his years of help, patience, and support. Without him, this book would not have been possible.

DORA HARNED  
Chico, California



Dora and her husband Don started the monthly insulator magazine Insulators-Crown Jewels of the Wire in March 1969. I submitted my first article in October 1975. Dora deserves special mention because it was she who always encouraged me to write, and always accepted my articles, and never edited one word I wrote. Without her encouragement and support, I certainly never would have continued researching and writing, and this book never would have been written. Don and Dora have been loyal friends for over 25 years, and I thank them for their friendship and generosity throughout those years.



FRANKLIN JAQUISH  
Covington, Kentucky



Franklin is my "Covington Connection", and has been helping me with Covington history since about 1980. He has found and sent me things that I never could have gotten otherwise. He is interested in history also, and knows much about Covington and the surrounding area. No matter what I asked of him, photos or information, he would get it for me. He went out to cemeteries, the library, and made several trips to historical locations and photographed them for me, always doing it just the way I wanted, always going "beyond the call of duty". And Franklin would not accept any payment for what he did for me. I'll always be grateful to my right-hand man in Covington. His tireless efforts have added much to this book.

JOHN AND CAROL McDOUGALD  
St. Charles, Illinois



Carol is editor of Crown Jewels of the Wire magazine, having taken the reins in 1985. Both John and Carol have been extremely helpful to me with my book, offering their assistance and encouragement from the beginning, along with answering my many questions and giving sound advice. Anything I asked of them, they didn't hesitate to do. The beautiful photos of Hemingray insulators were done by John, given to me to have them screened, and permission granted to use them in my book. And, they wouldn't take a penny for their expenses for film and postage. Also, Carol has always encouraged my writing, enthusiastically accepting my articles for her magazine, and she never edited one word. How can one properly thank such good friends as these? But I do offer my thanks to both of them for their generosity and friendship throughout the years.

FRED PADGETT  
Livermore, California



Fred is one of the very nicest people I've ever met. There's just something special about him. He has been a constant source of help and encouragement to me in getting my book together. Many times I became discouraged, but after talking to Fred, he seemed to take all of the kinks out, and things didn't look so bad after all. I thank him for his great descriptions of the furnace photos, and for the information on furnaces in general. Because of him, we all now know much more about them. My thanks go to Fred for "being there".

BOB STAHR  
St. John, Indiana



Bob is a Hemingray historian and collector whose knowledge of the subject is fantastic and growing all the time. I've only known Bob for a short time, but in that time I've seen his enthusiasm for anything Hemingray, and it is such a pleasure to talk with him. We have spent hours on the phone just talking Hemingray. I am truly grateful to Bob for taking time to proofread my manuscript. Many errors were caught and some inconsistencies uncovered. His attention to detail has really improved my book. I thank Bob for the hours he has spent helping me, and for the many other contributions he has made. Everything has been truly appreciated.

MR. N. R. WOODWARD  
Houston, Texas



Mr. Woodward is a true pioneer in the insulator hobby. His knowledge of insulators is tremendous, and he is always willing to share what he knows with anyone who asks. Mr. Woodward has been so patient with my many questions over the years, and he has never once refused to help. Besides his many contributions to my book, both to the text and with illustrations, he generously took the time to proofread my manuscript, not once, but several times. To me, it is an honor to know him, let alone to have had his help with my book. Words alone can't thank him enough, but they will have to do. I thank him most sincerely.

---

ROSELLA E. CARTWRIGHT  
Muncie, Indiana

This lady has really done a huge amount of research for me, finding newspaper ads, obituaries, and articles. She was the first one to send me the beautiful Hemingray bottle ad. It was so large that it arrived on four pieces of paper, but I couldn't believe my eyes when I saw it. I thank Rosella for the wonderful material she found for me.

THE CINCINNATI HISTORICAL SOCIETY  
Cincinnati, Ohio

As busy as these people are, they were of tremendous help to me, especially a lady named Linda Bailey, curator of prints and photographs. She spent a lot of time looking for the things I asked for, and went even beyond that, sending me the beautiful photo of the Hemingray Glass Company at Covington with the sidewheeler in the foreground. I thank Linda very much for her help with my project.



HIGHLAND CEMETERY  
Fort Mitchell, Kentucky

I just have to mention Rebecca Haake, who took the time to photocopy every cemetery record card related to Hemingray for me. This was truly a big help in finding out where some of the people were buried, and the cause of death. Rebecca also drew maps for me of several family plots, locating and naming the graves. I appreciate her help very much.

THE KENTON COUNTY PUBLIC LIBRARY  
Covington, Kentucky

My thanks go also to Charles D. King, local history librarian, who has been quite helpful in searching for and sending me historical data from that area. In fact, he found the obituary and photo of Daniel Hemingray, which just about knocked me over when I saw it. I will always be grateful to Mr. King for this and the many other things he found for me.

WILLIAM MORGAN AND PAT MUNDY  
Muncie, Indiana

Bill and Pat own the lovely old home in Muncie where Ralph Hemingray used to live, and in which Philip McAbee later lived with wife Carroll Hemingray McAbee. Bill sent me a big envelope which contained wonderful photos of the house today, some of which I've included in the book. He also sent me the early 1900s photo of the house, and the beautiful photo of the "mystery bride", which is truly a highlight of my book. Both Bill and Pat have been very cooperative, and I can't thank them enough for being so generous with their photos and information.

THE MUNCIE PUBLIC LIBRARY  
Muncie, Indiana

The staff at this library, especially Linda Mettler, reference librarian, has been so very good to me that I don't know where to start to thank them. I have sent request upon request, yet each letter has been answered with patience and kindness, as busy as they are. Linda has gone "the extra mile" for me many times, even finding items relating to Hemingray that I didn't ask for and didn't know existed. This book never would have been as complete as it is without this kind lady's help. My thanks go to Linda and everyone there for everything they have done.

LYNN C. MCCARTHY  
Frankfort, Kentucky

This lady spent many hours researching Hemingray and related genealogy for me. She knows just where to look and where to go, and found information I never would have found on my own. I thank her so much for her help. "The Family Tree Room" is more complete because of her.

DON McLAUGHLIN  
Los Angeles, California

Don McLaughlin is a son of glass manufacturer William McLaughlin, and it is an honor to have him take part in my book. Don and Fred Padgett studied my furnace photos and explained them to me, making those photos come alive. Also, the information they provided sharpened my knowledge of the glassmaking process. (Meeting Don and his brother Bob McLaughlin at the national in Long Beach in July of 1996 was a high point for me.) I thank Don for his help with my book.

ERN PARKISON  
Muncie, Indiana

Ern Parkison used to work at the Muncie factory. I first wrote to him in 1980, and then again when I started this book. He has been so very helpful to me, identifying buildings in photos, even telling me from what direction they were taken. He has helped me also with the glassmaking process at Hemingray. There's just nothing like experience. Ern was there, and is living history. I sincerely appreciate his help, which he has most generously given.

---

BALL STATE UNIVERSITY, A. M. BRACKEN LIBRARY,  
ARCHIVES & SPECIAL COLLECTIONS  
Muncie, Indiana

Nancy Turner, head, archives and special collections  
Donna Browne, archives and special collections technician

INSTA-PRINT  
San Diego, California  
Chuck Aiken, owner  
The late Cyndi Cott, manager  
1961-1997

LEXINGTON CEMETERY  
Lexington, Kentucky  
Daniel R. Scalf  
Dawn Scouten  
Mr. Wachs

LOS ANGELES PUBLIC LIBRARY  
Los Angeles, California  
Jane Nowak, manager, history and genealogy department

THE OLDE SAN DIEGO GAZETTE  
San Diego, California  
Karen Spring, editor-in-chief



SPRING GROVE CEMETERY  
Cincinnati, Ohio  
Margaret Meade, genealogist

ST. LOUIS PUBLIC LIBRARY  
St. Louis, Missouri  
Noel C. Holobeck, librarian

---

BOB AND PHOEBE ADAMS  
Miami, Florida

BILL AND MARILYN ALBERS  
Houston, Texas

DWAYNE ANTHONY  
Highland, California

RICK BALDWIN  
Brunswick, Ohio

DICK BALES  
Aurora, Illinois

EVELYN BOWMAN  
Webster, New York

JIM AND RUTH CRAWFORD  
Muncie, Indiana

JAMES DOTY  
Simi Valley, California

LYNN EBRO  
San Diego, California

ELTON GISH  
Buna, Texas

DAVE HALL  
Wilmington, California

ROGER AND ARLENE INSELMAN  
Fresno, California

TOM KATONAK  
Corrales, New Mexico

RAY KLINGENSMITH  
Cambridge, Ohio

JOHN MACKEN  
Muncie, Indiana

BILL MEIER  
Carlisle, Massachusetts

JOHN MILEK  
Webster, New York

DICK ROLLER  
Paris, Illinois

GRANT SALZMAN  
West Sacramento, California

JIM SANDERS  
Ojai, California

ED SMITH  
Seminole, Florida

RICK SOLLER  
Gurnee, Illinois

MIKE SOVEREIGN  
Lombard, Illinois

EARL J. STERNKE  
Milwaukee, Wisconsin

TIMOTHY STERNKE  
Milwaukee, Wisconsin

JERRY TURNER  
Goshen, Ohio

DONALD WENTZEL  
Millville, New Jersey

RICHARD WENTZEL  
Millville, New Jersey

(The photos in this section are credited and dated as follows:  
Wes Gordon (1990), Tommy Burnett (1989), Dora Harned (1985), and  
Bob Stahr (1997), author's photos. Glenn Drummond (1975), courtesy  
of Ed Smith. Mr. N. R. Woodward (1993), courtesy of Marilyn and Bill  
Albers. The following people provided their own photos: Franklin  
Jaquish (1950s), John and Carol McDougald (1995), and Fred Padgett (1997).)





The National Insulator Association (NIA) is an international organization of collectors and friends interested in electrical insulators, and other artifacts connected with the many industries associated with electrical power, such as telephone and telegraph, railroads, and lightning protection devices.

The NIA was founded on July 7, 1973, at the national show in Hutchinson, Kansas. It is a nonprofit educational and scientific organization aimed at encouraging insulator collecting and protecting the interests of its members, and has established standards and ethics by which its members may fairly deal with each other.

Each paid member will receive Drip Points, a quarterly newsletter published by the NIA, and a discount coupon towards the joint NIA/Crown Jewels of the Wire membership directory. Each member also receives a membership card entitling the holder to attend the official NIA Day at the NIA annual convention (only NIA members are allowed admission on NIA Day.) New members receive an NIA window decal and a copy of the NIA's Membership Handbook. Members are also entitled to insure their collection with an insurance plan designed especially for insulator collectors.

Any person interested in insulators, lightning rod equipment, or a related collecting or historical activity shall be eligible to apply for membership. Any insulator club may apply for a regular membership upon approval of its by-laws by the NIA board of directors. The fiscal year for membership dues starts and ends January 1 of each year. For more information on the NIA, please write to:

CLARICE GORDON  
3269 N. Mountain View Drive  
San Diego, CA 92116-1736

or

JOE J. BERES, NIA Membership Director  
1315 Old Mill Path  
Broadview Hts., OH 44147  
E-Mail JJB@AOL.COM

(NIA logo used with permission of, and text approved by, the NIA.)

## ABOUT THE AUTHOR

I have used my pen name, "H. G. 'Bea' Hyve", as author of this book. I have done so for several reasons. First of all, I have always written under this name, starting with my first article for Insulators--Crown Jewels of the Wire in October of 1975. (The magazine's name was changed slightly in 1985 when Carol McDougald took over as editor and the word "Insulators" was dropped.)



"Bea"

For many years most collectors had no idea who H. G. "Bea" Hyve was, but now most do know. Another reason why I use a "nom de plume" is because I've had a lot of fun with it. It is a play-on-words that fits the hobby that I love, and the insulators that I collect.

How did I choose such a name? In 1974 I decided to specialize in a certain type of insulator made by the Hemingray Glass Company, the H. G. CO. PETTICOAT beehive. Leaving out the "CO." and the "PETTICOAT", you are left with "H. G. beehive". Wanting to add a bit of mystery to it, I came up with a variation in spelling; "H. G. 'Bea' Hyve". (For more information on my pseudonym, please see the November 1993 issue of Crown Jewels of the Wire page 25 paragraph 2.)

My real name is Clarice Gordon, and I and my husband of 28 years, Wes, live in San Diego, California. Wes and I married in March of 1969, the same month and year that Crown Jewels started publication. I was born in San Diego in 1939 and have never lived anywhere else, having been in my present home since 1964; over 33 years. I graduated



Our beehive collection at its peak.  
Rochester, NY  
10 Jul 1983  
(Courtesy of Phoebe Adams)



from Herbert Hoover High School in 1957, and went to one year of college at San Diego State, majoring in elementary education and Spanish. I started working in 1957, and after two jobs, wound up at San Diego Transit (the city bus company) in 1960. I began as a keypunch operator and became an IBM tab machine operator in 1965. In 1970 I went part-time as a data entry clerk, quitting in 1990. Since then I have thoroughly enjoyed being a homemaker, and writing articles for Crown Jewels of the Wire.

Wes and I love to travel, and we attend as many insulator shows as possible, with the national every summer being our high point of the year. We also enjoy camping, and we've been to almost every state in the continental United States, as well as to Canada and Mexico. But our favorite place to camp is in Death Valley National Park in California, where we've spent some time every spring for the past nine years. We hope to keep on traveling, camping, and collecting for as long as possible.

(Photo of author (1990) from author's collection.)

-----

I want to give my readers an outstanding example of the willingness to help that I received with my book. Bob Stahr was proofreading a Xerox copy of my book, when he noticed that I had a Brookfield CD 263 on page 202 instead of a Hemingray. It's amazing to me that he noticed that at all, considering that he was working with just a copy, and a poor one at that. Bob was willing to take a Hemingray Columbia out of his collection, drive from St. John, Indiana, to St. Charles, Illinois, a drive of an hour and a half through suburban Chicago traffic, to have John and Carol McDougald photograph the insulator for me. As it turned out, the McDougalds had one in their sales stock, which they photographed, and sent three copies to me from which to choose. But Bob would have made that drive for me. All of this was done without any expectations of credit or reimbursement. In fact, John and Carol would not take a penny for their time, film, or postage. There's no way to properly thank such good friends as these. But that's a classic example of the quality of friends that our hobby of insulator collecting produces.

-----

# SOOZIE

Soozie, our cover girl, is an H. G. CO. PETTICOAT beehive, CD 145. She first saw the light of day in Covington, Kentucky, around 100 years ago. Her first memories are of being rather warm as she was picked out of her mold and set on a conveyer belt moving toward the annealing lehr. After going through the lehr with hundreds just like herself (with just slight variations in embossing and color), she was put on a wire rack to cool. Then she was washed and packed in a barrel.

The next light she saw (after a bumpy ride in the barrel which lasted several days) was when she was hoisted up to a crossarm in a leather bucket. She was placed onto a wood pin, her home for the next 84 years! She sat atop a pole near Bowie, Arizona, close to the famous Apache Pass where Cochise and his Chiricahua Apaches ruled years earlier. She endured many types of weather, and performed her duty extremely well as she sat on the pole doing railroad signal work beside a busy track. She must have been very sturdy, because she never got a stress crack or a chip in all those years.

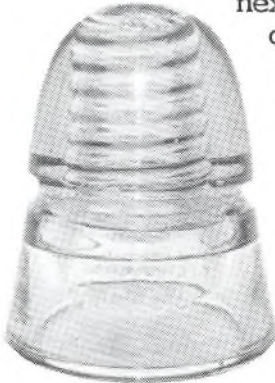

Soozie

Early one morning in 1970 some men came along and removed her from the pin, tossing her unceremoniously into a box with other insulators. Fortunately she was made of strong stuff, for even then she didn't get one bruise or scratch. After another uncomfortable ride lasting about eight hours, she and her boxmates were put in a back room. A few days later a lady came in, picked out the best insulators in the box, and put some of them out in the front area on shelves and in drawers. Because Soozie was just a plain aqua color, she was put in a drawer.

That night she got to talking with some of the other insulators, and found out from some who had been there a while that she was in an antique shop in Cortez, Colorado. She was flabbergasted to hear that in that same shop was a Muncie, a Coolie, and even a Pluto, all of them in mint condition, just as she was. It was an honor to be in the same room with such high-class pieces.

A few years went by, and many people came in to look at antiques and insulators, and although they bought many things, they sometimes never thought to look in the drawers. Even when they did, they just overlooked Soozie because she wasn't anything special.

But one day my family and I stopped for breakfast in a little town about 50 miles away. We noticed an antique shop next door to the restaurant with aqua insulators in the window. I asked my husband what that aqua glass thing was, and he said it was a resistor. The shop was closed, so we ate, and when we came out, the shop was still closed. But I made up my mind that at the very next antique shop I saw, I was going to get one of those resistors, because not only do I love glassware, but my favorite color is aqua.



The very next antique shop we saw was Country Boy Antiques in Cortez. (It is no longer there.) We went in and looked around. They had hundreds of resistors...it was a resistor bonanza. I don't know why I did it, but I opened a drawer, and there near the top was the prettiest, cleanest, clearest aqua piece of glass that I had ever seen. I bought it along with 19 others in various shapes, paying a dollar each.

Well, that was in the summer of 1972. I have since learned that "resistors" are insulators, and that Soozie is a beehive. And even though in the beginning of my insulator collecting I changed specialties several times, I never sold that little aqua beehive. Yes, Soozie was always special to me, and each time we'd display our beehives, she held her own right beside the ambers, purples, blues, and greens. To me, she was never common or ordinary. And although my original beehive collection is gone now, I still have Soozie. And as I try to rebuild my collection, she sits proudly beside my "newcomers", knowing that she has seniority.

Soozie's beauty was the reason I began specializing in H. G. CO. PETTICOAT beehives in 1973, and my curiosity over exactly what her embossings meant started me on my long road of Hemingray research. So Soozie was the beginning of something wonderful for me...she was the beehive that started it all! And she truly deserves to be a cover girl at long last.

TRADE MARK  
STANDARD HEMINGRAY INSULATORS  
REGISTERED.

LIST OF ABBREVIATIONS USED IN INDEX

AD-Advertisement	MAP-Map
ART-Article	O-Obituary
CH-Chart	PAT-Patent
CP-Catalog page	PH-Photo
DOC-Document	SIG-Signature
EXP-Explanation	SK-Sketch
LST-List	TR-Trademark registration

LIST OF PUBLICATION NAME ABBREVIATIONS USED IN INDEX

ABK-Atlas of Boone, Kenton, and Campbell Counties, KY  
CA-Cist's Advertiser  
CAC-City Atlas of Covington, KY  
CCC-Cincinnati Chamber of Commerce  
CCD-Covington City Directory  
CDI-Cincinnati Daily Inquirer  
CP-Cincinnati Post  
C&GJ-Crockery & Glass Journal  
DC-(Covington) Daily Commonwealth  
DH-(Muncie) Daily Herald  
EA-Electrical Age  
EACC-Electric Appliance Co. catalog  
EL&P-Electric Light & Power  
EMFEY-EMF-Electrical Yearbook  
ER-Electrical Review  
ERJ-Electric Railway Journal  
EW-Electrical World  
EW&E-Electrical World & Engineer  
EW1-Electrical West  
GCBM&CA-Gray's Cincinnati Business Mirror & City Advertiser  
GSLBD-Gould's St. Louis Business Directory  
HCC-Hemingray Co. catalog  
HDC-A History of Delaware County, Indiana, Vol. II  
HKK-A History of Kentucky and Kentuckians  
JAIEE-Journal of the American Institute of Electrical Engineers  
JEP&G-Journal of Electricity, Power and Gas  
JM&SCC-Joslyn Mfg. & Supply Co. catalog  
KP-Kentucky Post  
LAT-Los Angeles Times  
MCB&F-McCarthy Bros. & Ford catalog  
MCD-Muncie City Directory  
MDN-Muncie Daily News  
MDT-Muncie Daily Times  
MEP-Muncie Evening Press  
MIISI-Muncie Indiana: Illustrating Some of Its Industries  
MMN-Muncie Morning News  
MMS-Muncie Morning Star  
MPPF-Muncie, Past, Present, Future  
MP-Muncie Press



MS-Muncie Star  
MSS-Muncie Sunday Star  
MT-Muncie Times  
MWECC-Mid-West Electric Co. catalog  
OBC-Ohio Brass Co. catalog  
O-I-Owens-Illinois brochure  
OG-Official Gazette of the United States Patent Office  
SBMI-A Souvenir Booklet of Muncie, IN  
SSC-Sketches and Statistics of Cincinnati  
TA-Titus' Atlas, Hamilton County, OH  
WCD&BA-Williams' Cincinnati Directory & Business Advertiser  
WE-Western Electrician  
WEC-Western Electric catalog

Note: The Index which follows is not in alphabetical order, but in page number order. However, items will still be easier to find this way than by leafing through the book. (Use the list of abbreviations at the top of the previous page.)

The dates following the photos in most publications are the dates of the publication itself and not that of the photo.





# INDEX

PH-CD 115.....	vii
PH-CD 230.....	ix

## HEMINGRAY PEOPLE, PART I

PH-CD 241.....	1
CH-Chart-Company locations, years, number of years there.....	4
AD-WCD&BA-Gray & Hemingray-1850-1851.....	5
SIG-Samuel J. Hemingray.....	6
SIG-Ann Hemingray.....	7
SIG-Robert Hemingray.....	7
SIG-Mary E. Hemingray.....	7
ART-MDT-Married fifty years-6 Jun 1892.....	8
ART-Typed version of above.....	9
SIG-Ralph G. Hemingray.....	11
PH-MMS-Ralph Gray Hemingray-12 May 1920.....	12
PH-HDC-Ralph Gray Hemingray-1924.....	13
SIG-D. C. Hemingray.....	15
PH-Daniel Carroll Hemingray-Jul 1893.....	16
PH-KP-Daniel Carroll Hemingray-14 Dec 1911.....	17
SIG-J. C. Hemingray.....	19
SIG-Maria G. Hemingray.....	19
SIG-Richard Evans.....	20
SIG-Mary J. Evans.....	20
SIG-James L. Foley.....	21
PH-HKK-Bradford Shinkle-1917.....	22
SIG-A. Clifford Shinkle, Jr.....	23
PH-HKK-Amos Clifford Shinkle-1917.....	24
SIG-Philip W. McAbee.....	25
PH-MS-Philip W. McAbee-8 Nov 1948.....	26
SIG-Ralph Gray.....	27
SIG-James C. Gill.....	28
SK-MMS-W. P. Zimmerman-24 Jan 1936.....	29
LST-Positions held by various people at Hemingray, 1848-1933.....	30
AD-JAIEE-Hemingray Glass Co.-Apr 1930.....	36
LST-Where the people are buried.....	38
MAP-Highland Cemetery, Ft. Mitchell (Covington), KY.....	40
MAP-Close-up of Hemingray plot, Highland.....	41
PH-Long view of Hemingray monument, Highland-Jun 1983.....	42
PH-Close-up of Hemingray monument, Highland-Jun 1983.....	42
PH-Grave of Robert Hemingray-Highland-Jun 1983.....	43
PH-Grave of Robert C. Hemingray-Highland-Jun 1983.....	43
PH-Grave of Daniel C. Hemingray-Highland-Jun 1983.....	43
PH-Grave of Ralph G. Hemingray-Highland-Jun 1983.....	43
PH-Evans monument-Highland-Sep 1997.....	44
PH-Grave of Richard Evans-Highland-Sep 1997.....	44
PH-Grave of Mary J. Hemingray Evans-Highland-Sep 1997.....	44
MAP-Close-up of Shinkle plot-Highland.....	45
PH-Long view of Shinkle monument-Highland-Jun 1983.....	46
PH-Close-up of Shinkle monument-Highland-Jun 1983.....	46



PH-Close-up of engraving on Shinkle monument-Highland-Jun 1983.....	47
PH-Grave of M. Carroll McAbee-Beech Grove Cemetery, Muncie, IN-1997.	47
PH-Grave of Ralph Hemingray McAbee-Beech Grove-1997.....	47
PH-Grave of Philip Warrington McAbee-Beech Grove-1997.....	47
MAP-Linden Grove Cemetery, Covington, KY.....	48
PH-Long view of graves of Anthony and Susan Gray-Linden Grove-1997..	49
PH-Close-up of graves of Anthony and Susan Gray-Linden Grove-1997...	49
PH-Grave of Anthony Gray-Linden Grove-1997.....	50
PH-Grave of Susan Carroll Gray-Linden Grove-1997.....	50
PH-Long view of Gray monument-Spring Grove Cem., Cin., OH-Jun 1997..	51
PH-Close-up of Gray monument-Spring Grove-Jun 1997.....	51
O-CDI-Ralph Gray-1 Dec 1863.....	52
O-CDI-Samuel J. Hemingray-11 Sep 1866.....	52
O-KP-Robert Hemingray-27 Dec 1898.....	53
O-MDH-Robert Hemingray-27 Dec 1898.....	54
O-MMN-Robert Hemingray-29 Dec 1898.....	54
O-Typed version of above.....	55
O-KP-Robert Hemingray-29 Dec 1898.....	56
O-WE-Robert Hemingray-7 Jan 1899.....	56
O-MT-Jane Matthews (Mrs. Ralph) Hemingray-3 Sep 1900.....	57
O-MDN-Robert C. Hemingray-27 Jul 1901.....	57
O-Typed versions of above.....	58
O-MDH-Robert C. Hemingray-27 Jul 1901.....	59
O-KP-Mary Carroll (Mrs. Robert) Hemingray-27 May 1901.....	60
O-KP-Robert C. Hemingray-27 Jul 1901.....	60
O-MMS-James C. Gill-18 Jan 1902.....	61
O-MMS-James C. Gill-19 Jan 1902.....	61
ART-KP-Will was probated-Ann Gray-17 Jan 1903.....	62
AD-EW&E-Hemingray Glass Co.-20 Jun 1903.....	62
O-KP-Daniel C. Hemingray-14 Dec 1911.....	63
O-Typed version of above.....	64
AD-JAIEE-Hemingray Glass Co.-Nov 1907.....	65
O-MMS-Daniel C. Hemingray-15 Dec 1911.....	66
O-KP-Daniel C. Hemingray-15 Dec 1911.....	67
O-MMS-Daniel C. Hemingray-18 Dec 1911.....	69
AD-ERJ-Hemingray Glass Co.-4 Mar 1916.....	70
O-CCC-Daniel C. Hemingray-1912.....	71
O-LAT-Nannie T. (Mrs. Robert C.) Hemingray-13 Jun 1915.....	72
O-MEP-Nannie T. (Mrs. Robert C.) Hemingray-15 Jun 1915.....	72
O/PH-MMS-Ralph G. Hemingray-12 May 1920.....	73
O-Typed version of above.....	74
O-MMS-Ralph G. Hemingray-12 May 1920.....	75
ART-MMS-Estate of Ralph Hemingray valued at \$150,000-21 May 1920....	76
ART-Typed version of above.....	76
O-MS-Eva Hollinger (Mrs. Ralph) Hemingray-22 Feb 1947.....	77
O-MS-Mintie Carroll Hemingray (Mrs. Philip) McAbee-27 Feb 1947.....	77
ART-MS-Will of Carroll H. McAbee est. trust estate-4 Mar 1947.....	78
ART-MS-Will of Eva H. Hemingray creates 2 trust funds-15 Mar 1947...	78
O-MS-Philip McAbee-8 Nov 1948.....	79
O-MS-Philip McAbee-9 Nov 1948.....	80
O-MS-Philip McAbee-10 Nov 1948.....	80
AD-EL&P-Owens-Illinois-Jun 1949.....	80
DOC-Card issued to visitors to Hemingray silver display-1975.....	81



## HEMINGRAY PLACES, PART II

PH-CD 113.....	83
CH-Locations of Gray & Hemingray's residences, etc.-1849-1857.....	85
MAP-Eastern United States.....	86
MAP-Close-up of north central United States.....	87
EXP-SSC-Gray & Hemingray-1851.....	88
EXP-SSC-Gray, Hemingray, & Bros.-1859.....	89
MAP-WCD&BA-Cincinnati and Covington factory sites-1860.....	90
AD-WCD&BA-R. Hemingray & Co.-1868.....	91
MAP-TA-Cincinnati factory site-1869.....	92
AD-GCBM&CA-Gray & Hemingray-1851-1852.....	93
MAP-TA-Cincinnati factory site-1869.....	94
MAP-CDI-Cincinnati factory site-Oct 1984.....	94
AD-CA-Gray & Hemingray-30 Jul 1852 through 29 Apr 1853.....	95
MAP-Cincinnati factory site today.....	95
PH-Hammond St., Cincinnati, OH, looking east-28 May 1992.....	96
PH-Hammond St. looking west-28 May 1992.....	96
PH-Hammond St. looking south-28 May 1992.....	97
PH-Hammond St. looking north-28 May 1992.....	97
MAP-ABK-Covington factory site-1883.....	98
MAP-Covington factory site-1852-1861.....	99
MAP-Covington factory site-1861-1863.....	99
MAP-CAC-Covington factory-1877.....	100
MAP-Covington factory site-Sanborn Insurance-1886.....	101
EXP-The Sanborn Map Company.....	101
PH-Long view of Covington factory-C. 1868.....	102
PH-Same scene as above today-28 May 1992.....	103
PH-Close-up of Covington factory-C. 1868.....	104
ART-DC-Company's move to Covington-1 Feb 1881.....	104
PH-Close-up of Covington factory-C. 1880.....	105
PH-Long view of Covington factory-C. 1880.....	106
AD-GSLBD-Hemingray Glass Co. at St. Louis, MO-1873.....	107
PH-Location of Hemingray branch office, St. Louis-30 Jul 1997.....	108
AD-C&GJ-Hemingray Glass Co.-15 Jun 1876.....	108
PH-NW corner of 2nd and Madison St., Covington, KY-23 Aug 1976.....	110
MAP-KP-Proposed redevelopment section, Covington-3 Nov 1981.....	111
MAP-Covington factory site.....	111
PH-Covington site after fire looking west-3 Nov 1981.....	112
PH-Vault after fire-3 Nov 1981.....	112
PH-Safe after fire-3 Nov 1981.....	113
PH-Back of safe after fire-3 Nov 1981.....	113
PH-NW corner of 2nd and Madison St. looking north-C. 1980.....	114
PH-Same view after fire-Nov 1981.....	114
PH-Same view today-Sep 1996.....	114
PH-NW corner of 2nd and Madison St. looking south-23 Aug 1976.....	115
PH-Same view after fire-Nov 1981.....	115
PH-Same view today-Sep 1996.....	115
PH-Close-up of Hemingray offices looking west-Nov 1980.....	116
PH-Behind building between floodwall looking west-23 Aug 1976.....	116
ART-KP-Excavation along river yields history-13 Jun 1986.....	117
ART-KP-Beam tops off RiverCenter II-7 Mar 1997.....	118
PH-River Center dock looking north-May 1992.....	119
PH-River Center Drive looking west-May 1992.....	119



PH-CP-Bird's-eye view of Ohio River looking west-13 Sep 1996.....	120
SK-MPPF-Muncie factory-1893.....	121
AD-Hemingray Glass Co.-Jun 1913.....	122
ART-T-The story of Hemingray insulators, 1848-1904-May 1904.....	123
AD-OG-Hemingray Glass Co.-29 Mar 1910.....	124
SK-MIISI-The Muncie factory-1939.....	125
AD-MS-Hemingray Glass Co.-25 Sep 1927.....	126
AD-MEP-Hemingray Glass Co.-27 Sep 1927.....	127
ART-MS-Office burns, loss is \$10,000-22 Feb 1927.....	128
PH-ER-Blow-up of Muncie office building-30 Nov 1907.....	129
PH-ER-Blow-up of 3 men on porch-30 Nov 1907.....	129
PH/ART-ER-The Hemingray Glass Company-30 Nov 1907.....	130
PH-Glass Block Office Bldg-Muncie, IN-Jun 1996.....	131
EXP-Owens-Illinois builds additional office building.....	131
PH-Muncie office and plant looking east-C. 1924.....	132
PH-Same view-19 May 1981.....	133
PH-Close-up of limestone panel-19 May 1981.....	133
MAP-Muncie factory, aerial view-Apr 1948.....	134
EXP-Details of the Muncie plant map (above).....	135
EXP-Identifying some of the buildings on the map (above).....	136
PH-Scene at Muncie looking east-C. 1962.....	137
PH-Gas valve/meter at Muncie.....	138
PH-Newer warehouses at Muncie-19 May 1981.....	138
PH-Air-pumping building and water-cooled air intake-19 May 1981....	139
PH-Pile of insulators out back.....	139
PH-Raw materials silo-19 May 1981.....	140
PH-Doors into batch mixer-19 May 1981.....	140
PH-Tank stack and monitors-19 May 1981.....	141
PH-Various service buildings-19 May 1981.....	141
PH-Mold shop building, later cullet shed-19 May 1981.....	142
PH-Close-up of sign from cullet shed-19 May 1981.....	142
PH-Making TV face panels at Muncie (2 photos)-1964.....	143
ART-MEP-Owens-Illinois will close factory here-20 Jun 1972.....	144
PH-Muncie factory office building-Nov 1995.....	145
MAP-Muncie, IN.....	146
PH-Muncie dump-1975.....	147
EXP-Ralph Hemingray home, Muncie.....	148
AD-EW-Hemingray Glass Co.-C. 1900.....	149
PH-MCD-Ralph Hemingray home-C. 1902.....	150
PH-Ralph Hemingray home-19 Sep 1995.....	151
PH-Ralph Hemingray home-7 Aug 1996.....	152
PH-Daniel Hemingray home, Covington-Jul 1983.....	153
PH-Same as above, south side-Jul 1983.....	153
PH-Robert C. Hemingray home, Covington-Jul 1983.....	154
PH-Site of Robert Hemingray home, Covington-Jul 1983.....	154
LST-Residences of Hemingray people in Covington, 1860-1920.....	155
LST-Residences of Hemingrays in Muncie, 1889-1924.....	159

HEMINGRAY THINGS, PART III

PH-CD 214.....	161
AD-WCD&BA-Gray & Hemingray-1849-1850.....	163
AD-WCD&BA-R. Hemingray & Co.-1869.....	164
AD-WCD&BA-R. Hemingray & Co.-1870.....	165



AD-WCD&BA-Hemingray Glass Co.-1871.....	166
AD-CCD-Hemingray Glass Co.-1878.....	167
PH-Hemingray lamp and beehive insulator.....	168
DOC-Hemingray invoice-head-7 Oct 1896.....	169
PH-Hemingray lamp.....	170
DOC-Hemingray letter-15 May 1897.....	171
PH-Globe fruit jar.....	172
AD-OG-Globe fruit jars-3 Feb 1903.....	173
AD-"LOWEX" logo from advertising brochure-C. 1939.....	173
CP-Hemingray Glass Co.-1 May 1903.....	175
DOC-Hemingray invoice-18 Jun 1903.....	176
AD-Copy of 3-color porcelain Hemingray sign-C. 1908.....	177
PH-Hemingray mineral water and beer bottle (2 photos).....	178
PH-Mold assembly for CD 214.....	179
AD-Glass press-C. late 1800s.....	180
PAT-Insulator press-12 Jan 1909.....	181
PH-Interior of "B" furnace looking north-C. 1930.....	182
PH-Exterior of "A" furnace looking north-Mar 1997.....	182
PH-Post card showing the Hemingray Glass Co. at Covington-C. 1868..	184
PH-Hemingray bird dish.....	185
AD-EW&E-Hemingray Glass Co.-27 Dec 1902.....	186
AD-EW-Hemingray Glass Co.-23 Dec 1909.....	187
PH-Minnehaha refrigerator water bottle.....	188
AD-EW-Hemingray Glass Co.-30 Jun 1923.....	189
AD-T-Hemingray Glass Co.-Oct 1903.....	190
PH-Insulators at Muncie-4 Nov 1914.....	191
PH-Hemingray darkeys-18 Nov 1914.....	192
PH-SBMI-Muncie factory-C. 1915.....	195
CP-Armstrong's-Showing how glass insulators are made-1950.....	196
PH-MS-Insulators coming out of the Lehr at Muncie-25 Sep 1927.....	198
CP-Inspecting CD 122s at Muncie-C. 1946.....	199
SK-Gauge used to test insulators-12 Dec 1904.....	201
PH-CDs 263, 175, 208, 128.4, 205, 307.....	202
PH-CDs 152, 196, 106, 213, 302, 160.....	203
PH-MEP-Blow-up of Muncie office building and factory-27 Sep 1927...	204
AD-EMFEY-Hemingray Glass Co.-1923.....	205

THE FAMILY TREE ROOM

PH-CD 257.....	207
LST-Genealogy chart numbers for those on charts and in text.....	210
LST-The Hemingray family tree.....	211
CH-Genealogy chart-William/Mariah Barlow Hemingray.....	212
CH-Genealogy chart-George/Harriett Hemingray.....	213
CH-Genealogy chart-William/Ann Johnson Hemingray.....	214
CH-Genealogy chart-Charles/Catherine Hemingray Horner.....	215
CH-Genealogy chart-Samuel J./Ann Hemingray.....	216
CH-Genealogy chart-Robert/Mary Carroll Hemingray.....	217
CH-Genealogy chart-William H./Camilla Hemingray Felix.....	218
CH-Genealogy chart-Amos C./Sarah Hughes Shinkle.....	219
CH-Genealogy chart-Bradford/Anna J. Hemingray Shinkle.....	220
CH-Genealogy chart-Amos C./Frances Hinkle Shinkle.....	221



CH-Genealogy chart-Bradford/Mary Carroll Hemingray Shinkle.....	222
CH-Genealogy chart-Moses/Maria R. Pack Swasey.....	223
CH-Genealogy chart-Edward D./Catherine Hemingray Swasey.....	224
CH-Genealogy chart-Ralph G./Jane Matthews Hemingray.....	225
CH-Genealogy chart-Philip W./M. Carroll Hemingray McAbee.....	226
CH-Genealogy chart-Ralph G./Eva Hollinger Hemingray.....	227
CH-Genealogy chart-Robert C./Anna Timberlake Hemingray.....	228
CH-Genealogy chart-Daniel C./Clara Keck Hemingray.....	229
CH-Genealogy chart-Reuben/Caroline Hemingray.....	230
CH-Genealogy chart-Joseph C./Maria G. Hawn Hemingray.....	231
CH-Genealogy chart-Reuben P./Lida Blacker Hemingray.....	232
CH-Genealogy chart-Charles W./Lillian K. Hemingray Chambers.....	233
CH-Genealogy chart-Richard G./Mary Jane Hemingray Evans.....	234
CH-Genealogy chart-Ralph/Ann Friar Gray.....	235
CH-Genealogy chart-Anthony/Susan Carroll Gray.....	236
CH-Genealogy chart-James L./Juliet Barnes Foley.....	237
CH-Genealogy chart for the Grays.....	238

#### THE MAIL ROOM

PH-CD 162.....	239
DOC-Letter to author from Ern Parkison-27 Nov 1996.....	242
DOC-Letter from O-I to employees about plant closing-19 Jun 1972...	244
DOC-Letter to Glenn Drummond from O-I-1 Apr 1976.....	245
DOC-Letter to Hemingray from lawyer Arthur Stem-7 Dec 1888.....	246

#### THE NEWS ROOM

PH-CD 151.....	249
ART-MDT-Glass works-12 Jul 1887.....	252
SK-OBC-CD 160-1899.....	252
ART-MDT-The mammoth glass factory-14 Jul 1887.....	253
ART-MDN-Muncie's prosperity-5 Jan 1888.....	254
ART-MDN-Our list (of local factories)-6 Jan 1888.....	255
ART-MDN-(Mr. Hemingray to locate new glass works here)-6 Jan 1888..	256
SK-OBC-CD 164-1899.....	256
ART-MDT-Covington's loss-13 Jan 1888.....	257
ART-MDN-New switch lines-13 Jan 1888.....	258
SK-OBC-CD 106-1899.....	258
ART-MDT-Over and Hemingray's (fire)-18 Jun 1892.....	259
SK-OBC-CD 196-1899.....	262
ART-MDN-\$250,000 (fire)-18 Jun 1892.....	263
ART-DH-Great conflagration-18 Jun 1892.....	268
ART-MDT-From another source-20 Jun 1892.....	271
SK-OBC-CD 283-1899.....	272
ART-MDN-Around the ruins-20 Jun 1892.....	273
ART-DH-Will rebuild-20 Jun 1892.....	275
SK-OBC-CD 162-1899.....	275
ART-MDT-Factories and mills-22 Jun 1892.....	276
ART-MDT-Losses being adjusted-24 Jun 1892.....	277
ART-MDN-Sweat! Sweat!-24 Jun 1892.....	277
ART-MDT-Muncie notes (Mr. Robert Hemingray)-27 Jun 1892.....	278



ART-MDN-Muncie's glass prospects-29 Jun 1892.....	279
ART-MDT-Among the factories-30 Jun 1892.....	280
ART-MDT-General notes (wife of Ralph Hemingray sick)-30 Jun 1892...	280
ART-MDT-Will rebuild larger than before-30 Jun 1892.....	280
ART-MDT-Factory and mill items of interest gathered-8 Jul 1892.....	281
ART-MDT-The Hemingrays (move part from Cov.)-27 Jul 1892.....	282
SK-OBC-CD 280-1899.....	282
ART-MDT-In memory of '76-20 Jan 1897.....	283
ART-MDT-Young Elks organize-24 Feb 1897.....	284
ART-MDT-A close call from destruction-29 Sep 1897.....	284
ART-KP-Start made (Covington Glass Co.)-28 Jun 1898.....	285
ART-KP-New company-28 Sep 1898.....	285
ART-KP-May leave (Covington Glass Co.)-28 Sep 1898.....	286
SK-OBC-CD 263-1899.....	286
ART-KP-Sale ordered (Covington Glass Co.)-29 Nov 1898.....	287
ART-MMS-Hemingrays to stay here-6 May 1901.....	288
ART-MMS-(Thomas J. Conway sent wife to Oregon)-6 May 1901.....	289
ART-MMS-Glass plant is now idle-7 May 1901.....	289
SK-OBC-CD 282-1899.....	290
ART-MMS-Invention a success (glass pressing machine)-13 Apr 1907...	291
ART-MSS-Glass company has fine record-6 Dec 1925.....	292
SK-OBC-CD 134-1899.....	293
ART-MMS-Glass company ready to make beer bottles-16 Mar 1933.....	294
ART-MMS-Owens-Illinois Company buys local industry-4 May 1933.....	295
SK-OBC-CD 257-1899.....	297
ART-MMS-Made manager at Hemingrays (W. P. Zimmerman)-3 Feb 1934....	298

#### THE AD ROOM

PH-CD 154.....	299
ART/AD-WE-Hemingray Glass Co.-24 Dec 1898.....	302
AD-EW&E-Hemingray Glass Co.-29 Jun 1901.....	303
AD-EW&E-Hemingray Glass Co.-28 Dec 1901.....	304
AD-JEP&G-Hemingray Glass Co.-Jan-Dec 1903.....	305
ART/AD-EW&E-Hemingray Glass Co.-7 Feb 1903.....	306
AD-ER-Hemingray Glass Co.-23 May 1903.....	307
AD-ER-Hemingray Glass Co.-30 May 1903.....	308
AD-EA-Hemingray Glass Co.-Feb 1904.....	309
AD-EA-Hemingray Glass Co.-Mar 1904.....	310
AD-T-Hemingray Glass Co.-Dec 1904.....	311
AD-ER-Hemingray Glass Co.-13 May 1905.....	312
AD-ER-Hemingray Glass Co.-14 Apr 1906.....	313
AD-JEP&G-Hemingray Glass Co.-5 Jan 1907.....	314
AD-ER-Hemingray Glass Co.-29 Jun 1907.....	315
AD-EW-Hemingray Glass Co.-7 Sep 1907.....	316
AD-ER-Hemingray Glass Co.-11 Jan 1908.....	317
AD-ER-Hemingray Glass Co.-7 Mar 1908.....	318
AD-ER-Hemingray Glass Co.-16 May 1908.....	319
AD-EW-Hemingray Glass Co.-27 May 1909.....	320
AD-EW-Hemingray Glass Co.-17 Jun 1909.....	321
AD-EW-Hemingray Glass Co.-22 Jun 1911.....	322
AD-T-Hemingray Glass Co.-28 Dec 1912.....	323



AD-T-Hemingray Glass Co.-14 Jun 1913.....	324
AD-T-Hemingray Glass Co.-4 Jul 1914.....	325
AD-EW-Hemingray Glass Co.-30 Dec 1911.....	326
AD-ERJ-Hemingray Glass Co.-18 Mar 1916.....	326
AD-EW-Hemingray Glass Co.-27 Dec 1924.....	327
AD-ERJ-Hemingray Glass Co.-Dec 1930.....	328
AD-ERJ-Hemingray Glass Co.-Jun 1931.....	329
AD-EW1-Owens-Illinois-Jun 1935.....	330
AD-EW-Owens-Illinois-19 Jun 1937.....	331
AD-EW-Owens-Illinois-3 Jul 1937.....	332
AD-EW-Owens-Illinois-1 Jan 1938.....	333
AD-EW-Owens-Illinois-21 May 1938.....	334
AD-EW-Owens-Illinois-4 Jun 1938.....	335
AD-EW-Owens-Illinois-19 Nov 1938.....	336
CP-EACC-1909-1910.....	337
CP-WEC-1915.....	344
CP-MWECC-1918.....	349
CP-HCC-15 May 1921.....	352
CP-HCC-15 May 1921.....	353
CP-MCB&F-1920.....	356
CP-HCC-15 May 1921.....	360
CP-WEC-1922.....	361
CP-JM&SCC-1934.....	364
CP-O-I-LOWEX-1940.....	372
CP-O-I-C. 1942-1944.....	380

THE "CATCH-ALL" ROOM

PH-CD 164.....	381
PH-The mystery bride-24 Apr 1907.....	384
EXP-The mystery bride.....	385
PH-Ralph G. Hemingray (see page 12 for credit).....	385
PH-Carroll McAbee? (see page 384 for credit).....	385
PH-Daniel C. Hemingray (see page 16 for credit).....	385
ART-MP-Hemingray-McAbee-24 Apr 1907.....	386
ART-Typed version of above.....	387
ART-MMS-Social and personal news-25 Apr 1907.....	389
ART-Typed version of above.....	390
ART-HDC-History of the Hemingray Glass Co.-1924.....	391
DOC-History of Muncie Owens-Illinois-C. 1968.....	392
DOC-Act of Incorporation-1870.....	393
EXP-Drip points.....	395
LST-Incomplete list of registered trademarks and patents.....	397
PAT-2 May 1893.....	398
PAT-19 Dec 1871.....	400
PAT-13 Nov 1883.....	403
PAT-12 Feb 1884.....	405
TR-"HEMINGRAY"-Various dates.....	407
TR-"LOWEX"-Various dates.....	409
EXP-Furnace notes.....	410
PH-"B" furnace-south end-C. 1940.....	412
PH-Possibly "A" furnace-date unknown.....	412



PH-"B" furnace-close-up of south end-C. 1940.....	413
PH-"B" furnace-west side looking south-C. 1949.....	413
PH-"B" furnace-north end-C. 1930.....	414
PH-Possibly "A" furnace-date unknown.....	414
PH-"B" furnace-south end-C. 1930.....	415
PH-"B" furnace-south end-C. 1949.....	415
PH-"B" furnace-west side looking south-C. 1930.....	416
PH-Possibly "A" furnace, ports 2 and 1-date unknown.....	416
PH-"B" furnace-east side, port 5-C. 1940.....	417
PH-Possibly "A" furnace, ports 5 and 4-date unknown.....	417
PH-"B" furnace-east side looking south, ports 4 and 5-C. 1930.....	418
PH-"B" furnace-east side, port 1-C. 1940.....	418
PH-"B" furnace-east side, port 2-C. 1940.....	419
PH-"B" furnace-west side looking north-C. 1930.....	419
PH-"B" furnace-east side looking north, ports 1, 2, and 3-C. 1930..	420
PH-"B" furnace-east side looking north, port 1-C. 1930.....	420
EXP-Furnace photos.....	421
SK-Old-style tank furnace.....	424
PAT-8 Aug 1916.....	426
EXP-Furnace photos.....	430
PH-"A" furnace looking northwest-Mar 1997.....	431
PH-Close-up of feeder area-Mar 1997.....	431
PH-"A" furnace looking north-Mar 1997.....	432
PH-Back of "A" furnace looking southeast-Mar 1997.....	432
PH-"B" furnace looking northwest-Mar 1997.....	433
PH-Close-up of "B" furnace showing feeder area-Mar 1997.....	433
PH-"B" furnace-south end-May 1997.....	434
PH-"B" furnace looking south-May 1997.....	434
PH-"B" furnace-north end-May 1997.....	435
PH-"B" furnace-west side looking north-May 1997.....	435
PH-"B" furnace-east side looking north-May 1997.....	436
PH-Semi-circular refining chamber-May 1997.....	436
PH-Furnace floor showing crackled glass-May 1997.....	437
PH-Iron cleanout door at base of "A" furnace chimney-Mar 1997.....	437
SK-Embossing on iron doors.....	438
PH-Iron cleanout door at base of "B" furnace chimney-May 1997.....	438
ART-OG-Relating to insulator patent controversy-22 Jul 1873.....	439
DOC-Owens-Illinois job history-13 Oct 1954.....	441
DOC-Speech given at awards ceremony-1948.....	442

#### THE BOOK ROOM

PH-CD 194/195.....	447
LST-Insulator and go-with publications.....	450

#### FINAL NOTES

PH-CD 122.....	453
PH-Wes Gordon-1990.....	455
PH-Tommy Burnett-1989.....	456
PH-Glenn Drummond-1975.....	456
PH-Dora Harned-1985.....	456

PH-Franklin Jaquish-1950s.....	457
PH-John McDougald-1995.....	457
PH-Carol McDougald-1995.....	457
PH-Fred Padgett-1997.....	457
PH-Bob Stahr-1997.....	458
PH-Mr. N. R. Woodward-1993.....	458
EXP-National Insulator Association.....	463
EXP-About the author.....	464
PH-H. G. "Bea" Hyve-1990.....	464
PH-Our beehive collection at its peak-10 Jul 1983.....	464
EXP-Soozie.....	466
PH-CD 145-Soozie.....	466
LST-Abbreviations used in Index.....	468
LST-Publication name abbreviations used in Index.....	468
LST-Index.....	471
The End.....	481

TRADE MARK  
 STANDARD **HEMINGRAY** INSULATORS  
 REGISTERED.



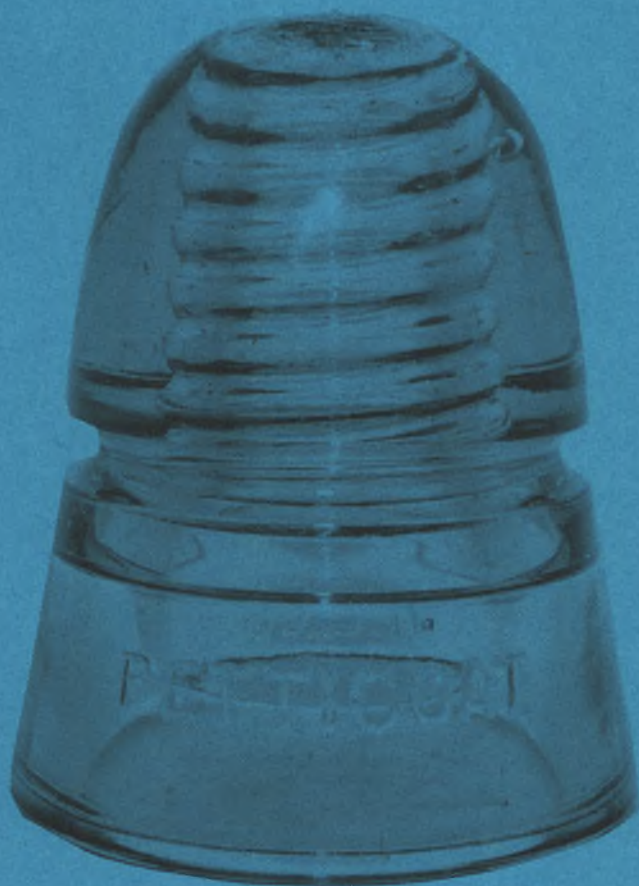

**THE END**





